



The original
TOMMY GATE[®]
hydraulic lift

PRODUCT CATALOGUE

**CRANE
SALES**

0800 64 64 26 | www.mimico.co.nz

MIMICO

WHO WE ARE

Crane Sales New Zealand Ltd commenced operations in 2007, servicing and supplying cranes to any industry. Based in Matamata and servicing throughout Aotearoa. Crane Sales New Zealand Ltd specialises in all your crane needs to meet any requirement.

With over 14 years in the industry you can lift with confidence as Crane Sales New Zealand Ltd have experienced staff who will source new and used parts from around the world no matter how hard the task. We provide any make, any model such as HMF, UNIC, Rozzi, TAM, Kobelco, Tadano, Terex, NCK, Komatsu, Hyundai, Doosan.

In addition, We sell and support many respectable brands including HMF knuckle boom and marine cranes, UNIC mini crawlers, Maxilift truck cranes and Tommy Gate hydraulic liftgates.

When you buy a new crane, you need to know:

Will it perform the tasks required?

Is it a reliable, well supported brand?

Are service staff on call in case of damage or breakdown?

Can spare parts be sourced quickly if required?

Talk to us today.



CONTENTS

G2 SERIES - UTES AND TRUCKS

OVERVIEW 4-5

MODELS AND SPECIFICATIONS 6

'LIFT N' DUMP' - TIPPERS

OVERVIEW 8

MODELS AND SPECIFICATIONS 9

GBR RAILGATE - UTES AND TRUCKS

OVERVIEW 10

MODELS AND SPECIFICATIONS 11

CANTILEVER SERIES - VANS

OVERVIEW 12

MODELS AND SPECIFICATIONS 13

650 SERIES - VANS

OVERVIEW 14

MODELS AND SPECIFICATIONS 15

V2 SERIES - VANS

OVERVIEW 16

MODELS AND SPECIFICATIONS 17

HISTORY - TOMMYGATE

18-19

250+
YEARS
KNOWLEDGE

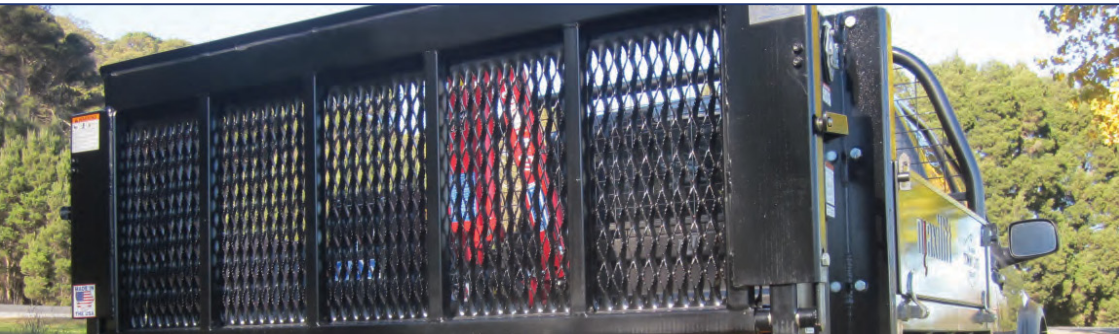

FOR UTES

G2 SERIES OVERVIEW

AND TRUCKS

THE SECOND GENERATION:

- A DUAL-CYLINDER, PARALLEL-ARM DESIGN WHICH UTILISES A PAIR OF HYDRAULIC CYLINDERS TO LOWER AND RAISE THE LIFT BY APPLYING DIRECT POWER TO BOTH SIDES OF THE PLATFORM

DUAL DRIVE ADVANTAGES:

- G2 LIFTGATES PROVIDE INCREASED DURABILITY FOR RIGOROUS CYCLING
- HAVE RELATIVELY-LOW MAINTENANCE REQUIREMENTS
- A PAINT-BEFORE-ASSEMBLY PROCESS INCREASES THE LONGEVITY OF THE LIFTGATE'S AESTHETICS

THE FEATURES MATTER:

- THE G2 SERIES FEATURES ONLY TWO GREASE POINTS AND THE HARD-CHROME PINS ARE VIRTUALLY MAINTENANCE FREE
- DUAL HYDRAULIC CYLINDERS ARE BUILT IN-HOUSE
- PRECISION CYLINDER WELDS ARE EXECUTED BY ROBOTIC MACHINES
- VIRTUALLY MAINTENANCE-FREE COMPONENTS
- RECESSED CONTROL
- LARGER PLATFORMS
- FULLY-ENCLOSED HYDRAULIC SYSTEM LOCATED WITHIN THE LIFTGATE MAINFRAME
- SAFETY TIME-OUT SYSTEM

WATCH VIDEO:

- OVERVIEW **G2 SERIES** 



TOW BAR COMPATIBLE

EASY ON-GROUND LOADING



TRUCKS



UTES



HEAVY LIFTS



APPLICATIONS

STEEL TREADPLATE

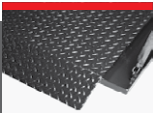

EXTRUDED ALUMINUM

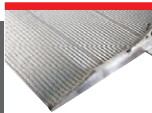

TOMMY TRACTION

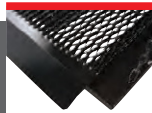

EXTRUDED MESH



PLATFORM MATERIALS

TOW BAR COMPATIBLE



ENCLOSED LED LIGHT KIT



DUAL CONTROLS



FOLDING TYRE RACK*



*OPTIONAL

FEATURES & OPTIONS

PAINT BEFORE ASSEMBLY

G2 SERIES

| MODEL | CAPACITY KG | FRAME WIDTH MM | PLATFORM OPTION | LOAD AREA W x D MM | WEIGHT KG |
|-------|-------------|----------------|-----------------|--------------------|-----------|
| MINI | 460 | 1245 | TP | 1162 X 787 | 136 |
| | | | EA | 1114 X 838 | 135 |
| G2-54 | 590 | 1397 | TP38 | 1239 X 978 | 195 |
| | | | EA38 | 1260 X 978 | 178 |
| G2-60 | 590 | 1549 | TP38 | 1390 X 978 | 214 |
| | | | TT27 | 1438 X 692 | 207 |
| | | | EA38 | 1413 X 978 | 195 |
| G2-65 | 590 | 1695 | TP38 | 1572 X 978 | 225 |
| | | | TT27 | 1572 X 692 | 231 |
| | | | EA38 | 1530 X 978 | 205 |
| G2-73 | 590 | 1854 | EA38 | 1690 X 978 | 224 |

AVAILABLE MODELS FOR UTES AND LIGHT TRAY TOPS

| MODEL | CAPACITY KG | *FRAME WIDTH MM | PLATFORM OPTION | *LOAD AREA W x D MM | WEIGHT KG |
|-------|-------------|-----------------|-----------------|---------------------|-----------|
| G2-60 | 730 | 1549 | TT33 | 1413 X 848 | 230 |
| G2-65 | 730 | 1695 | EA41 | 1529 X 1052 | 211 |
| G2-73 | 730 | 1854 | TP35 | 1730 X 899 | 240 |
| | | | TT33 | 1730 X 848 | 243 |
| | | | EA41 | 1689 X 1053 | 221 |
| | | | EM48 | 1730 X 1219 | 249 |
| G2-87 | 730 | 2210 | TP35 | 2086 X 899 | 268 |
| | | | TT33 | 2086 X 848 | 269 |
| | | | EA41 | 2045 X 1053 | 245 |
| | | | EM48 | 2090 X 1249 | 278 |
| G2-92 | 730 | 2337 | EA41 | 2172 X 1053 | 254 |
| | | | TP41 | 2213 X 1049 | 289 |

AVAILABLE MODELS FOR TRUCK SIZE LIFT GATES

TP - STEEL TREADPLATE EA - EXTRUDED ALUMINUM TT - TOMMY TRACTION™ EM - EXTRUDED MESH

DIMENSIONS

* REFER TO ABOVE TABLES FOR DIMENSIONS

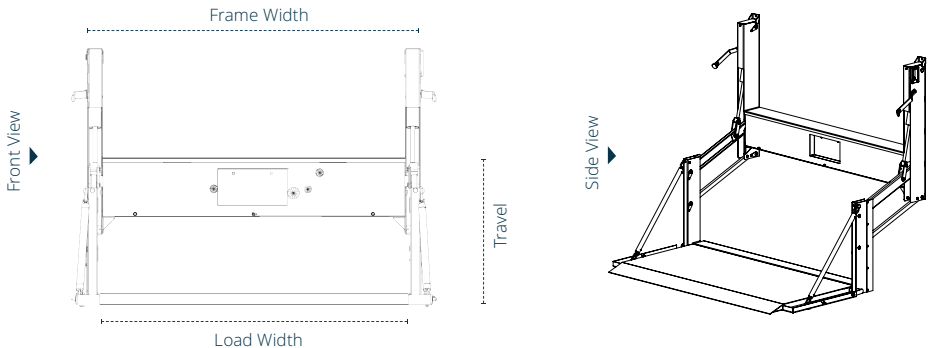



The original
TOMMY GATE[®]
hydraulic lift

FOR A MORE LIFT 'N' DUMP OVERVIEW VERSATILE TIPPER

DUAL DRIVE ADVANTAGES:

- G2 LIFTGATES PROVIDE INCREASED DURABILITY FOR RIGOROUS CYCLING
- HAVE RELATIVELY-LOW MAINTENANCE REQUIREMENTS
- A PAINT-BEFORE-ASSEMBLY PROCESS INCREASES THE LONGEVITY OF THE LIFTGATE'S AESTHETICS

THE FEATURES MATTER - LIFT 'N' DUMP:

- DUAL HYDRAULIC CYLINDERS, LIKE ALL G2 SERIES MODELS
- LIFT-N-DUMP MODELS FEATURE PINS TO LOCK THE LIFT'S PLATFORM IN PLACE WHEN NOT IN DUMP-THROUGH MODE
- PLATFORM LATCH ACTIVATES THE LIFTGATE'S DUMP-THROUGH POSITION

THE FEATURES MATTER - G2 SERIES:

- DUAL HYDRAULIC CYLINDERS
- VIRTUALLY MAINTENANCE-FREE COMPONENTS
- RECESSED CONTROL
- FULLY-ENCLOSED HYDRAULIC SYSTEM
- SAFETY TIME-OUT SYSTEM
- ENCLOSED LED LIGHT KIT
- TOW BAR COMPATIBLE

WATCH VIDEO:

- OVERVIEW **LIFT 'N' DUMP**

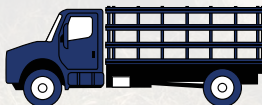

UNIQUE DUMP-THROUGH CAPABILITY



TIPPING



LOADING



VERSATILITY



APPLICATIONS



| MODEL | CAPACITY KG | *FRAME WIDTH MM | PLATFORM OPTION | *LOAD AREA W x D MM | WEIGHT KG | OPTIMUM BODY WIDTH MM |
|-------|-------------|-----------------|-----------------|---------------------|-----------|-----------------------|
| G2-73 | 730 | 1854 | TP34 | 1654 X 864 | 269 | 1900 |
| G2-81 | 730 | 2045 | TP34 | 1870 X 864 | 288 | 2100 |
| G2-87 | 730 | 2210 | TP34 | 2010 X 864 | 299 | 2200 |
| G2-92 | 730 | 2337 | TP34 | 2137 X 864 | 309 | 2400 |

AVAILABLE MODELS - 1270 MM TRAVEL

DIMENSIONS

* REFER TO ABOVE TABLE FOR DIMENSIONS

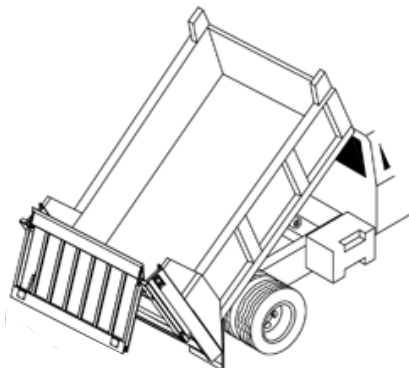

Side View

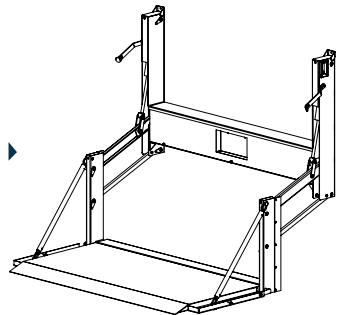

AN EXACT GBR RAILGATE OVERVIEW VERTICAL LIFT

GBR RAILGATE ADVANTAGES:

- EXPERTLY-ENGINEERED LIFT THAT ALLOWS FOR HIGHER WEIGHT CAPACITIES
- LEVEL-RIDE FUNCTION
- STANDARD MODEL RAILGATES EMPLOY A PADDED SLIDER SYSTEM

THE FEATURES MATTER:

- SAFETY TRIP BAR
- TORSION SPRING PLATFORMS
- RECESSED LIGHTS
- EASY FOLD GAS BOTTLE RACKS
- PLATFORM DROP DOWN FUNCTION - ALLOWS WORK VEHICLES TO LOAD / UNLOAD IN ANY MANNER / LOCATION

A LITTLE MORE ABOUT HIGH-CYCLE RAILGATE MODELS:

- EMPLOYS A STEEL ROLLER AND LEAF-CHAIN PULLEY SYSTEM TO MAXIMIZE SMOOTHNESS OF MOTION, ENDURANCE, AND STRENGTH
- IDEAL FOR HIGH-CYCLE APPLICATIONS IN ANY ENVIRONMENT
- BUILT WITH THE HIGHEST QUALITY COMPONENTS AND PLACE A PRIORITY ON FUNCTION AND SAFETY

WATCH VIDEO:

- OVERVIEW **GBR RAILGATE**



* HIGH-CYCLE RAILGATE MODELS ARE INTENDED FOR USE ON MEDIUM-DUTY TRUCKS ONLY
** TOMMY GATE CAPACITY IS RATED FOR ANYWHERE ON THE PLATFORM. FURTHER OPTIONS, INC ADDITIONAL BODY SIZES AVAILABLE. CONTACT YOUR MAXILIFT DEALER FOR MORE INFORMATION



HIGHER WEIGHT CAPACITY

EASY FOLD GAS BOTTLE RACKS*



HIGH-CYCLE DRIVE SYSTEM ONLY

VERTICAL LOWERING FOR EASY LOADING



EASY DOCK OR FORKLIFT LOADING



FOLDS AWAY



DOCK-FRIENDLY

| MODEL | CAPACITY KG | PLATFORM OPTION | *LOAD AREA W x D MM | WEIGHT KG |
|-----------|-------------|-----------------|---------------------|-----------|
| 89-20-GBR | 910 | GBR | 2260 X 762 | 365 |
| 89-25-GBR | 1135 | GBR | 2100 X 762 | 475 |

AVAILABLE MODELS

DIMENSIONS

Front View

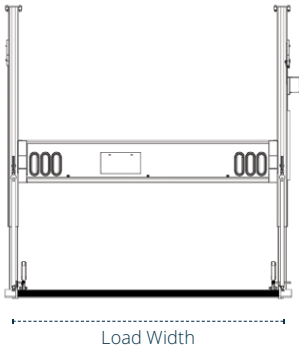

Side View

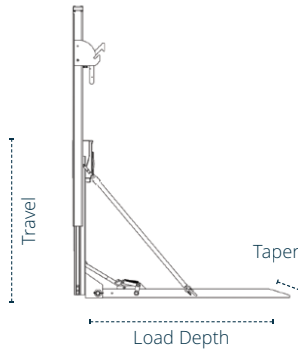

*REFER TO ABOVE TABLE FOR DIMENSIONS. STANDARD MODEL SHOWN

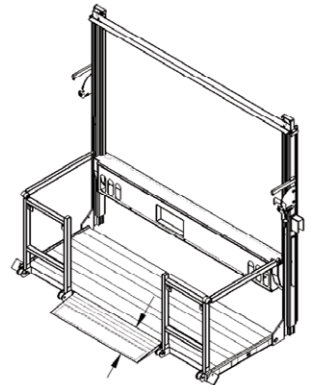

FOR COMMERCIAL CANTILEVER SERIES OVERVIEW VANS

CANTILEVER SERIES ADVANTAGES:

- A MODERN HYDRAULIC LIFT THAT IS SPECIFICALLY DESIGNED TO OPERATE SEAMLESSLY WITH COMMERCIAL VANS
- THE CULMINATION OF YEARS OF ENGINEERING, CANTILEVER SERIES MODELS ARE HIGHLY VERSATILE AND INCLUDE NUMEROUS DESIRABLE FEATURES
- EASY TO USE AND HIGHLY EFFICIENT, CANTILEVER SERIES MODELS ARE AESTHETICALLY PLEASING AS WELL AS LOGISTICALLY PRACTICAL

THE FEATURES MATTER:

- A BOLT-ON UNDERSIDE MOUNT IS COMPATIBLE WITH MOST MODERN VANS AND ELIMINATES THE NEED FOR ANY WELDING
- THE PLATFORM IS CONSTRUCTED FROM CORROSION-RESISTANT ALUMINUM AND FOLDS Laterally, ALLOWING FOR ACCESS TO THE REAR OF THE VEHICLE WITHOUT OPERATING THE LIFT
- PLATFORMS SUPPORT A LARGE LOADABLE AREA AND COME STANDARD WITH DUAL CART STOPS
- EMPLOYS INTERNAL BRIDGES, DUAL CART STOPS, REMOTE PENDANT CONTROL, AND MAINTENANCE-FREE COMPONENTS

WATCH VIDEO:

- OVERVIEW **CANTILEVER SERIES**



* INSTALLATION MAY AFFECT SPECIFIC VEHICLE FEATURES SUCH AS REAR SENSORS AND BACK-UP CAMERAS

** INSTALLATION REQUIRES THE SPARE TYRE TO BE RELOCATED

*** MERCEDES-BENZ REQUIRES THE USE OF AN AUXILIARY BATTERY FOR ALL LIFTGATES INSTALLED ON SPRINTER® VANS

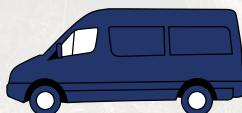

LOGISTICALLY PRACTICAL



'NO LIFT' REAR VAN ACCESS



LEFT: LARGER PLATFORM (EF71) HAS 1524MM LOADING DEPTH - RECOMMENDED FOR HIGH-ROOF VANS ONLY
RIGHT: SMALLER PLATFORM (EF52) HAS 1016MM LOADING DEPTH - IDEAL FOR LOW-ROOF VANS

INTERNAL BRIDGES



DUAL CART STOPS

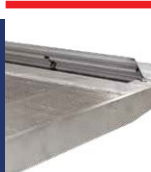

MAINTENANCE-FREE COMPONENTS



REMOTE PENDANT CONTROL



FEATURES

MODEL

CAPACITY KG

FITS BODY

*LOAD AREA W x D MM

WEIGHT KG

| | | | | |
|------------------|-----|---------------|-------------|-----|
| CVL-AA-1330-EF71 | 590 | HIGH ROOF VAN | 1346 X 1524 | 277 |
| CVL-AA-1330-EF52 | 590 | LOW ROOF VAN | 1346 X 1016 | 259 |

AVAILABLE MODELS - 762 MM TRAVEL

DIMENSIONS

*REFER TO ABOVE TABLE FOR DIMENSIONS

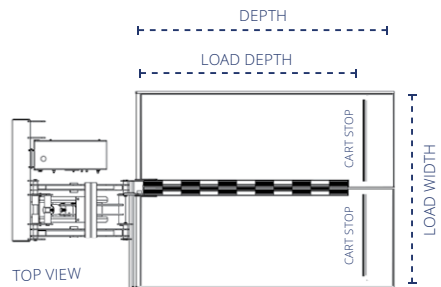
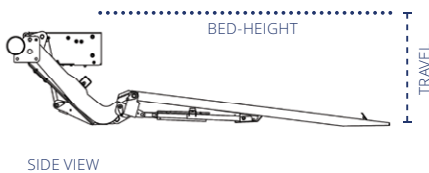

FOR COMMERCIAL 650 SERIES OVERVIEW VANS

650 SERIES ADVANTAGES:

- LOW-CAPACITY, COMPACT, AND INTERNALLY-MOUNTED
- THE IDEAL LIFTGATE FOR LIGHTWEIGHT VAN APPLICATIONS
- FOLD UP AND STORE OUT OF THE WAY OF ORDINARY TASKS OR FLAT AGAINST THE INSIDE OF THE REAR DOOR

THE FEATURES MATTER:

- AUTOMATICALLY-DEPLOYING STEEL BRIDGE SPANS THE GAP BETWEEN PLATFORM AND VAN BODY WHEN THE LIFT IS IN THE LOADING POSITION
- LOW-PROFILE STORAGE, THE LIFT STORES NEAR THE REAR OF THE VAN, MAXIMIZING THE USABLE SPACE OF THE TRUCK'S INTERIOR
- FOLD-AWAY INTERIOR MOUNT OFFERS TWO SECURE STORAGE POSITIONS AND EASY ACCESS TO THE REAR OF THE VAN

WATCH VIDEO:

- OVERVIEW 650 SERIES

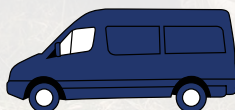

IDEAL FOR LIGHTWEIGHT TASKS

FOLD-AWAY INTERIOR MOUNT



STEEL BRIDGE



REMOTE PENDANT CONTROL



FEATURES



300KG
CAPACITY



SINGLE
CYLINDER



INTERNALLY
MOUNTING

| MODEL | CAPACITY KG | PLATFORM OPTION | *LOAD AREA W x D MM | WEIGHT KG |
|-------|-------------|-----------------|---------------------|-----------|
| 650 | 300 | TP | 762 X 990 | 177 |

AVAILABLE MODELS - 650-800 MM TRAVEL

DIMENSIONS

*REFER TO ABOVE TABLE FOR DIMENSIONS

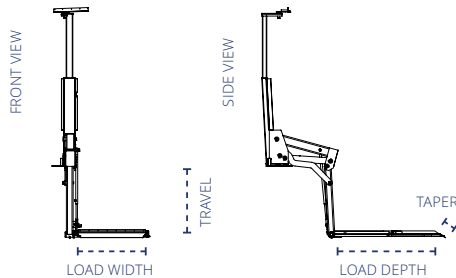

FOR COMMERCIAL V2 SERIES OVERVIEW VANS

V2 SERIES ADVANTAGES:

- EMPLOYS THE LATEST IN LIFTGATE TECHNOLOGY
- PROVIDES THE MAXIMUM PLATFORM LOADING AREA WHILE OCCUPYING THE SMALLEST POSSIBLE SPACE WHEN STORED IN THE REAR OF THE VAN
- COMBINES SLEEK MODERN ENGINEERING WITH HANDS-FREE PLATFORM OPEN AND CLOSE AND BUILT-IN CART RETENTION RAMP
- 500KG OF LIFTING CAPACITY

THE FEATURES MATTER:

- RETENTION RAMP EASILY LOCKS INTO PLACE TO SECURE WHEEL-BASED CARTS OR CARGO - FOOT OR HAND ACTIVATED
- ALUMINUM TREADPLATE BRIDGE MOUNTS PROVIDE SMOOTH TRANSITION FOR MOVING CARGO TO AND FROM LIFT PLATFORM TO VEHICLE BED
- PENDANT CONTROL WITH RAISE/LOWER TOGGLE AND SECONDARY PLATFORM FOLD FUNCTION
- PUMP AND MOTOR HOUSING FITS COMPACTLY OVER THE WHEEL WELL
- PLATFORM RESTS FLAT AT GROUND LEVEL, MINIMIZING LOAD ANGLE

WATCH VIDEO:

- OVERVIEW **V2 SERIES**

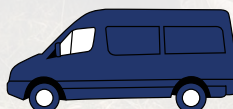

IDEAL FOR LIGHTWEIGHT TASKS

FOLD-AWAY INTERIOR MOUNT



RETENTION RAMP



TWO-FUNCTION CONTROL



LOW-PROFILE PUMP BOX

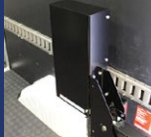

FLAT BED TAPER



FEATURES

| MODEL <small>FRAMED ALUMINUM PLATFORMS</small> | *LOAD AREA W x D MM | LIFT CAPACITY KG | UNIT WEIGHT KG |
|---|------------------------|---------------------|-------------------|
| V2-56-1140-FA34 | 1194 X 864 | 500 | 190 |
| V2-56-1140-FA49* | 1194 X 1245 | 500 | 227 |

**FA49 MODELS MUST HAVE THE 9" RETENTION RAMP/TAPER ENGAGED WHEN STORING THE PLATFORM ON LOWER ROOF VAN MODELS TO AVOID THE RAMP CONTACTING THE VAN FRAME - CONSULT WITH YOUR MAXILIFT DEALER.*

DIMENSIONS

**REFER TO ABOVE TABLE FOR DIMENSIONS*

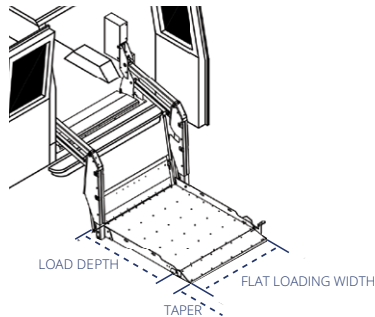



HISTORY

50+ YEARS OF QUALITY

WOODBINE MANUFACTURING COMPANY WAS FOUNDED IN 1965, IN WOODBINE, IOWA BY DELBERT "BUS" BROWN. WORKING ALONE, BUS DESIGNED AND CONSTRUCTED THE ORIGINAL TOMMY GATE HYDRAULIC LIFT, WHICH HE NAMED AFTER HIS SON.

EARLY STORIES OFTEN RECOUNT BUS LOADING HIS PICKUP TRAILER WITH UP TO FIVE LIFTGATES AT A TIME AND DRIVING OFF INTO THE NEIGHBORING COUNTIES (WHERE HE WOULD SELL AND INSTALL THEM HIMSELF), ONLY TO RETURN ONCE THAT TRAILER WAS EMPTY.

THIS WAS WOODBINE MANUFACTURING COMPANY IN ITS EARLIEST DAYS: A GRASSROOTS LIFTGATE MANUFACTURER THAT WAS CREATED TO EASE THE WORK OF THE LOCAL FARMERS.

TODAY, THE WOODBINE FACTORY STANDS AT OVER 60,960 SQUARE METERS ON THE SAME PIECE OF GROUND WHERE EVERY TOMMY GATE LIFTGATE HAS BEEN MANUFACTURED AND ASSEMBLED FOR OVER 50 YEARS. IT IS A STATE-OF-THE-ART MANUFACTURING PLANT THAT EMBRACES A COMBINATION OF MODERN TECHNOLOGY FUSED WITH OLD-FASHIONED, HANDS-ON WELDING AND TOOLING.

VERY MUCH ALIVE AND WELL IN THE TWENTY-FIRST CENTURY, TOMMY GATE LIFTGATES ARE SOLD BY OVER 1000 DISTRIBUTORS IN EVERY CORNER OF THE WORLD.

WOODBINE MANUFACTURING COMPANY IS ONE-HUNDRED PERCENT FAMILY-OWNED AND OPERATED, AND HAS BEEN SINCE ITS INCEPTION. THE COMPANY TAKES GREAT PRIDE IN THE WORK ETHIC, HISTORY, AND TRADITIONS OF ITS EMPLOYEES AND STRIVES TO CONTINUE PROVIDING JOBS AND OPPORTUNITIES TO THE COMMUNITY IT CALLS HOME.

IT IS A TESTAMENT TO THE SPIRIT OF AMERICAN MANUFACTURING THAT TOMMY GATE BEGAN WITH A SINGLE MAN, IN A SMALL, BRICK MACHINE SHOP IN RURAL IOWA.





IMPORTANT NOTES:

- TRADEMARKS ARE PROPERTY OF THEIR RESPECTIVE OWNERS
- INSTALLATION MAY AFFECT SPECIFIC VEHICLE FEATURES SUCH AS REAR SENSORS, BACK-UP CAMERAS, AND/OR TRAILER HITCHES
- ALL MEASUREMENTS IN MILLIMETERS AND KILOGRAMS, UNLESS OTHERWISE SPECIFIED
- "GATE WEIGHT" EQUALS THE INSTALLED LIFTGATE WEIGHT
- "LOAD AREA" IS THE LIFTGATE PLATFORM'S FLAT, LOADABLE AREA & IS GIVEN AS WIDTH X DEPTH
- DETAILED LIFTGATE DIMENSIONS ARE AVAILABLE TO VIEW AT TOMMYGATE.COM

SOME LEGALS:

- **SPECIFICATION CHANGES**
WOODBINE MANUFACTURING COMPANY, INC. RESERVES THE RIGHT TO MAKE CHANGES IN MANUFACTURING TO COMPLY WITH CURRENT OR NEW ENGINEERING SPECIFICATION CHANGES WHERE APPLICABLE
- **INSTALLATION COMPLIANCE**
BEFORE INSTALLING ANY LIFTGATE, PLEASE OBSERVE THE VEHICLE LOADING LIMITATIONS. THESE LOADING LIMITATIONS ARE OUTLINED IN THE VEHICLE OWNER'S MANUAL AND THE SAFETY COMPLIANCE CERTIFICATION LABEL LOCATED ON THE DRIVER'S DOOR PILLAR
- **INSTALLATION PROCEDURES**
LIFTGATE INSTALLERS ARE TO TREAT VEHICLES AS INCOMPLETE AND ARE THEREFORE RESPONSIBLE FOR VEHICLE COMPLIANCE WITH LOCAL, STATE, AND FEDERAL LIGHTING REGULATIONS (FMVSS 108). INSTALLERS ARE TO FOLLOW THE PROCEDURES AND SPECIFICATIONS AS DETAILED IN TOMMY GATE INSTALLATION INSTRUCTIONS. ADDITIONALLY, ALL WARNINGS AND INSTRUCTIONS OUTLINED IN TOMMY GATE OWNER'S MANUALS MUST BE FOLLOWED WHEN OPERATING ANY TOMMY GATE PRODUCT
- **WARNING**
TOMMY GATE LIFTGATES ARE INDUSTRIAL PRODUCTS FOR MATERIAL HANDLING ONLY AND ARE NOT TO BE USED AS A PERSONNEL OR WHEELCHAIR LIFT. FOR SAFE HANDLING AND OPERATING INSTRUCTIONS, VISIT WWW.TOMMYGATE.COM
- **WARRANTY LIMITATIONS, LIMITATIONS ON WOODBINE'S LIABILITY AND INDEMNIFICATION**
THE MODIFICATION OF ANY TOMMY GATE PRODUCT IN ANY MANNER NOT APPROVED BY WOODBINE MANUFACTURING COMPANY, INC. IMMEDIATELY VOIDS ALL WARRANTIES. WOODBINE MANUFACTURING COMPANY, INC. SHALL NOT BE HELD RESPONSIBLE FOR ANY DAMAGE RESULTING FROM THE USE OF A MODIFIED TOMMY GATE PRODUCT, OR ONE THAT WAS NOT PROPERLY MAINTAINED. THE MAXIMUM LIABILITY OF WOODBINE MANUFACTURING COMPANY, INC. RESULTING FROM ANYTHING IT DID OR DID NOT DO WITH RESPECT TO A TOMMY GATE PRODUCT SHALL BE THE PRICE PAID FOR THAT TOMMY GATE PRODUCT. WOODBINE MANUFACTURING COMPANY, INC. WILL NOT BE RESPONSIBLE FOR ANY LOSS OF PROFITS, GOODWILL, BUSINESS OPPORTUNITY OR CONSEQUENTIAL DAMAGES. RECIPIENTS ACCEPTING SHIPMENTS OF ANY TOMMY GATE PRODUCT AGREE TO INDEMNIFY, DEFEND, PROTECT, AND HOLD WOODBINE MANUFACTURING COMPANY, INC. HARMLESS FROM AND AGAINST ANY AND ALL LOSSES, DAMAGES CLAIMS OR EXPENSES OF WHATEVER FORM OR NATURE, INCLUDING ATTORNEYS' FEES AND OTHER COSTS OF DEFENSE THAT WOODBINE MANUFACTURING COMPANY, INC. MAY INCUR IN CONNECTION WITH ANY ACTS OR OMISSIONS RELATED TO THE USE OR MISUSE OF A TOMMY GATE PRODUCT

SOLUTIONS FOR NEARLY ANY APPLICATION.

Tommy Gate offers a full line of liftgates for any personal, commercial, or industrial application. Depending on your particular cargo-handling needs and your vehicle, certain liftgates may be more suitable than others.

