



DRIVETRAIN

Transmission:
4F/3R Proportional w/ Electronic Control
Module torque sensing autoshift/manual shift and modulation

Gears	Helical cut
Gear ratios	Forward/Reverse
1st	3.731/3.731
2nd	2.207/2.207
3rd	1.421/0.970
4th	0.625/ —

Torque converter:	
Stall ratio	2.511:1

Differential:
Front axle equipped w/ locking differential
Rear axle equipped w/ open differential

Rear axle oscillation	26° total
-----------------------	-----------

Front and rear axles:	
Differential ratio	4.25
Planetary ratio	6.35
Final axle ratio	27.00

Special application axles – standard:
Front axle equipped w/ locking differential
Rear axle equipped w/ open differential

Planetaries	Outboard
-------------	----------

Service brakes:
Hydraulically actuated, maintenance-free, multiple wet disc w/ accumulator to all four wheels

Brake surface area:	
Front hub – each	1,144 in ² (0.738 m ²)
Rear hub – each	1,144 in ² (0.738 m ²)

Parking brakes:
Spring-applied hydraulic release disc on transmission output shaft neutralizes power flow to wheels when engaged

Travel speeds – 4-speed transmission:		
	Forward	Reverse
	mph (kph)	mph (kph)
1st	4.3 (6.9)	4.3 (6.9)
2nd	7.2 (11.6)	7.2 (11.6)
3rd	11.0 (17.7)	15.8 (25.5)
4th	23.2 (37.4)	—

NOTE: Travel speeds at full engine throttle w/ 26.5 x 25 L3 Radial tires.

ELECTRICAL

Voltage	24 Volts, negative ground
Alternator	120 amp
Batteries (2)	12-volt

OPERATOR ENVIRONMENT

ROPS cab AC w/ heat; 8" LCD touchscreen display, adjustable armrest w/ 3 configurable buttons; Key start; Articulated power steering w/ tilt column; Fully adjustable, heated air-ride seat w/ head rest; AM/FM Bluetooth radio w/ auxiliary input; Cab convenience package: rear sun shade, interior mirror, under the seat drawer, 12V

accessory port, & coat hook; Foot throttle; Single lever (joystick) loader control w/ fully adjustable wrist rest, 2 cup holders; 2 interior rear view mirrors; 3 inch (76 mm) retractable seat belt; Integrated 4-corner strobe; Multiple storage trays; Single brake pedal; F/N/R shuttle switch; Left and Right external rear view mirrors; Sound suppression kit; Pressurized air filtering; Anti-glare window strip; Front and Rear Defroster; Side window, partial/fully open; 2 Dome lights; Wipers, rear and intermittent front; Windshield washers, front and rear; Rubber floor mat; Horn.

Displays/Gauges:

Digital:
Transmission oil temperature; Engine coolant temperature; Fuel level; DEF level.

LCD screen:
Hour meter; Time; FNR indication; Trip computer; Metric/english; Differential lock; Engine speed; Automatic trans indication; DeClutch indication; Fuel consumption; Engine diagnostics; Error reporting; Travel speed; Current gear selection; Engine mode indication; Multiple languages; Transmission diagnostics.

Audible/Visual alarms:

Warning lights:
Four-way flashers; High beam lights; Engine block heater; Low brake pressure; Parking brake.

Caution warnings:
Parking brake; Coolant temperature; Hydraulic oil temperature; Transmission oil temperature; Air filter; Transmission filter; Hydraulic filter; Alternator; Low fuel.

Critical warnings:
Engine oil pressure; Brake pressure; Steering pressure – w/ aux. steering*; Coolant temperature; Hydraulic oil temperature; Transmission oil temperature.

Backup alarm

Maintenance reminders:
Cab air filter; Engine oil filter; Fuel pre-filter; DEF tank vent filter; SCR supply filter; Hydraulic oil and filter; Engine air filter; Engine coolant; Drive belt; Cab recirculation filter; Engine breather filter; Transmission breather; Front and rear axle fluid; SCR supply module filter.

NOTE: *If equipped w/ option.

OPERATING WEIGHT

Z-Bar
Unit equipped w/ ROPS cab w/ heater and A/C; Standard counterweight; 26.5-R25 L3 Radial Tires; 6.25 yd³ (4.8 m³) GP pin-on w/ bolt on edge; Full fuel; 165 lb (75 kg) operator:
61,650 lb (27 964 kg)

XR

Unit equipped w/ ROPS cab w/ heater and A/C; Standard counterweight; 26.5-R25 L3 Radial Tires; 6.25 yd³ (4.8 m³) HD pin-on w/ bolt on edge; Full fuel; 165 lb (75 kg) operator:
63,443 lb (28 777 kg)

ENGINE

Make	FPT
------	-----

Model	F2CFE614F
-------	-----------

Emissions Certification	Tier 4 Final
-------------------------	--------------

Emissions Technology	SCR/DOC
----------------------	---------

Type	4-stroke, turbocharged and air-to-air cooler
------	--

Cylinders	6-cylinder in-line
-----------	--------------------

Bore/Stroke	4.61 x 5.31 in (117 x 135 mm)
-------------	----------------------------------

Displacement	531 in ³ (8.7 L)
--------------	-----------------------------

Fuel	#2 Diesel, #1 and #2 mixture permitted for cold temperatures
------	--

Fuel injection	Direct injection – electronic
----------------	-------------------------------

Fuel filter	Replaceable, full flow spin-on cartridge
-------------	--

Fuel pump	Bosch CP 3.3
-----------	--------------

Gradeability:	
Side-to-side	35°
Fore and aft	35°

Air filter	2-element dry type w/ warning restriction indicator
------------	---

Rear-mount cooling module w/ auto reversing fan:	
Rear-mount air/water w/ Lube Oil Cooler	

Fan – hydraulic driven:	
Style	9 blade puller
Diameter	36 in (914 mm)

Water pump	Integral
------------	----------

Engine oil pump operating angle ratings:	
Side-to-side	35°
Fore and aft	35°
Oil filtration	Replaceable, full flow spin-on cartridge

Engine speeds	RPM
Rated – full load	2100

Horsepower – Maximum Power:	
Peak gross @ 1800 RPM	345 hp (257 kW)
Net rated @ 2100 RPM	293 hp (218 kW)
Peak net @ 1800 RPM	329 hp (245 kW)

Torque – Maximum Power:	
Gross @ 1100 RPM	1,183 lb-ft (1 604 N-m)
Net @ 1100 RPM	1,154 lb-ft (1 564 N-m)

Net torque rise:	
Maximum power range	57%

NOTE: Gross horsepower and torque per SAE J1995. Net horsepower and torque per SAE J1349.

HYDRAULICS

Main pumps – steering/implement:

Closed center pressure/flow compensated

Tandem variable displacement – load-sensing

Max rated flow x2: 50.2 gpm @ 2000 RPM
(190 L/min @ 2000 RPM)

Loader control valve:

Closed-center, sectional 2, 3 or 4-function
w/ control for lift, tilt and auxiliary hydraulics

Loader auxiliary steering:

Hydraulic orbital center-pivot articulating
w/ on-demand oil flow

High pressure standby:

Implement 3,650 psi (25 165 kPa)
Steering 3,495 psi (24 097 kPa)

Filtration:

Filtered vent w/ relief on hydraulic reservoir,
maintains 3-5 psi on reservoir, 10-micron,
return filter furnishes only clean oil to all
components of the system

SERVICE CAPACITIES

Fuel tank 125 gal (473.0 L)

DEF tank – Diesel Exhaust Fluid:

Usable capacity 16 gal (61.0 L)
Total 24 gal (90.8 L)

Hydraulic system:

Reservoir 35.4 gal (134.0 L)
Total 66.0 gal (250.0 L)

Transmission:

Service w/ filter 48.0 qt (45.4 L)

Front and rear axle:

Front axle 67.6 qt (64.0 L)
Rear axle 67.6 qt (64.0 L)

Engine oil w/ filter 30 qt (28.5 L)

Cooling system 15 gal (56.8 L)

OTHER SPECIFICATIONS

Lift cylinder:

Bore diameter 7.00 in (177.8 mm)
Rod diameter 4.50 in (114.3 mm)
Stroke 34.48 in (875.8 mm)

Dump cylinder:

Bore diameter 8.00 in (203.2 mm)
Rod diameter 5.00 in (127.0 mm)
Stroke 27.35 in (694.7 mm)

Loader:

Z-Bar loader linkage; Single control for
lift and tilt; Positive hold float; Automatic
return-to-dig; Automatic height control;
Automatic return-to-travel; Brake pedal
transmission disconnect; Bucket position
indicator on bucket.

Cycle time:

Raise w/ rated bucket load 6.5 sec
Dump w/ rated bucket load 1.4 sec
Float down 2.8 sec

Sound level in Cab (LpA) 69 dB(A)

Exterior sound level (LwA) 104 dB(A)

NOTE: Sound level data tested in accordance
with ISO6395, 6396, 3744.

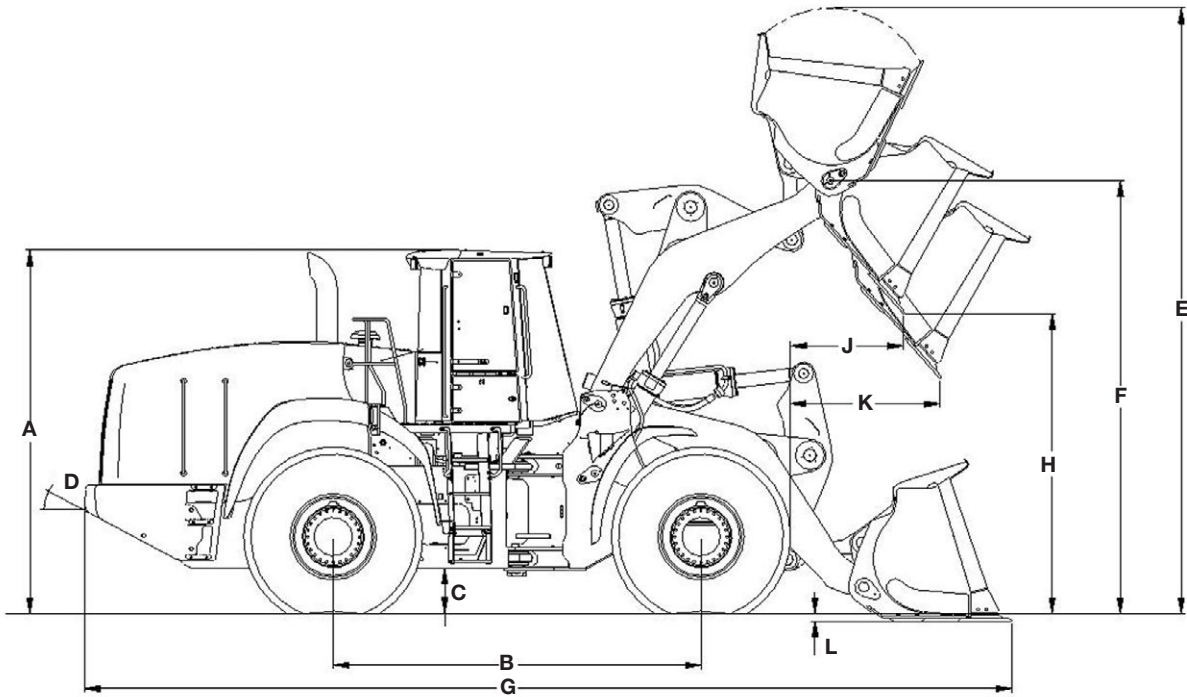

Line drawings are for illustrative purpose only and may not be exact representation of unit.

DIMENSIONS

A. Height to top of ROPS cab	140.8 in (3 576 mm)
Height to drawbar	44.8 in (1 137 mm)
B. Wheelbase	139.8 in (3 550 mm)
C. Ground clearance	17.2 in (437 mm)
D. Angle of departure, rear	23°
Width:	
Overall* without bucket	117.2 in (2 978 mm)
Tread width	90.6 in (2 300 mm)
Turning radius* – outside	250.6 in (6 366 mm)
Turning angle:	
From center	40°
Total angle	80°
Rear axle oscillation – total	26°

NOTE: *Dimensions taken with 26.5-R25 L3 Radial Tires. Additional dimensions on pages 4 through 5.

WEIGHT ADJUSTMENTS

Select Options	Weight Adjustment	Tipping Load Adjustment	
		Straight: Deflected*	40° Turn: Deflected*
26.5 x 25 L5 Radial Tires	+1,500 lb (+680 kg)	+1,323 lb (+600 kg)	+1,226 lb (+556 kg)

NOTE: Unit equipped with Z-Bar loader arms, 6.25 yd³ (4.8 m³) pin on bucket w/ bolt-on edge, 26.5-R25 L3 Radial Tires, ROPS cab with heater and A/C, full counterweight, front and rear fenders, full fuel and 165 lb (75 kg) operator. Adjust select options from rated weight.

*Tipping loads: ISO 14397-1 Deflected Tires.

PERFORMANCE SPECS

1121G Z-Bar*		6.25 yd³ (4.8 m³) Bucket with Bolt-on Edge - Pin On	6.1 yd³ (4.7 m³) Bucket with Teeth - Pin On
Operating weight		61,650 lb (27 964 kg)	61,646 lb (27 962 kg)
E.	Operating height – fully raised with spillguard	242.0 in (6 147 mm)	242.0 in (6 147 mm)
F.	Hinge pin height – fully raised	175.2 in (4 449 mm)	175.2 in (4 449 mm)
G.	Overall length – bucket level on ground	361.1 in (9 172 mm)	368.3 in (9 354 mm)
Dump angle – fully raised		50°	50°
H.	Dump height – fully raised, 45° dump	126.3 in (3 209 mm)	121.7 in (3 090 mm)
J.	Bucket reach – fully raised, 45° dump	50.1 in (1 273 mm)	55.4 in (1 406 mm)
K.	Bucket reach – 7 ft 0 in (2.13 m) height, 45° dump	80.4 in (2 043 mm)	83.5 in (2 121 mm)
L.	Dig depth	4.4 in (111 mm)	4.6 in (116 mm)
Operating load – ISO Rigid Tires		21,032 lb (9 540 kg)	21,166 lb (9 601 kg)
Operating load – ISO Deflected Tires		19,227 lb (8 721 kg)	19,345 lb (8 775 kg)
Maximum material density – ISO Rigid Tires		3,365 lb/yd ³ (1 997 kg/m ³)	3,470 lb/yd ³ (2 059 kg/m ³)
Maximum material density – ISO Deflected Tires		3,076 lb/yd ³ (1 825 kg/m ³)	3,171 lb/yd ³ (1 882 kg/m ³)
Tipping load – ISO Rigid Tires:			
	Straight	51,898 lb (23 541 kg)	52,231 lb (23 692 kg)
	40° turn	42,064 lb (19 080 kg)	42,331 lb (19 201 kg)
Tipping load – ISO Deflected Tires:			
	Straight	48,670 lb (22 076 kg)	48,973 lb (22 214 kg)
	40° turn	38,454 lb (17 443 kg)	38,691 lb (17 550 kg)
Lift capacity:			
	Full height	32,710 lb (14 837 kg)	32,662 lb (14 815 kg)
	Ground	56,904 lb (25 811 kg)	57,397 lb (26 035 kg)
Breakout force with tilt cylinder		49,934 lb (22 650 kg)	53,151 lb (24 109 kg)
Loader clearance circle with bucket		564.4 in (14 337 mm)	569.6 in (14 467 mm)

1121G XR		6.25 yd³ (4.8 m³) Bucket with Bolt-on Edge - Pin On	6.1 yd³ (4.7 m³) Bucket with Teeth - Pin On
Operating weight		63,443 lb (28 777 kg)	63,439 lb (28 776 kg)
E.	Operating height – fully raised with spillguard	258.4 in (6 564 mm)	258.4 in (6 564 mm)
F.	Hinge pin height – fully raised	191.6 in (4 867 mm)	191.6 in (4 867 mm)
G.	Overall length – bucket level on ground	377.2 in (9 580 mm)	384.3 in (9 761 mm)
Dump angle – fully raised		50°	50°
H.	Dump height – fully raised, 45° dump	142.8 in (3 626 mm)	138.1 in (3 508 mm)
J.	Bucket reach – fully raised, 45° dump	51.8 in (1 315 mm)	57.1 in (1 449 mm)
K.	Bucket reach – 7 ft 0 in (2.13 m) height, 45° dump	95.2 in (2 417 mm)	98.5 in (2 502 mm)
L.	Dig depth	4.4 in (111 mm)	4.6 in (116 mm)
Operating load – ISO Rigid Tires		18,264 lb (8 284 kg)	18,375 lb (8 335 kg)
Operating load – ISO Deflected Tires		17,204 lb (7 804 kg)	17,303 lb (7 848 kg)
Maximum material density – ISO Rigid Tires		2,922 lb/yd ³ (1 734 kg/m ³)	3,012 lb/yd ³ (1 787 kg/m ³)
Maximum material density – ISO Deflected Tires		2,753 lb/yd ³ (1 633 kg/m ³)	2,837 lb/yd ³ (1 683 kg/m ³)
Tipping load – ISO Rigid Tires:			
	Straight	44,370 lb (20 126 kg)	44,652 lb (20 245 kg)
	40° turn	36,527 lb (16 568 kg)	36,750 lb (16 670 kg)
Tipping load – ISO Deflected Tires:			
	Straight	42,640 lb (19 341 kg)	42,899 lb (19 459 kg)
	40° turn	34,408 lb (15 607 kg)	34,606 lb (15 697 kg)
Lift capacity:			
	Full height	31,251 lb (14 175 kg)	31,218 lb (14 160 kg)
	Ground	47,783 lb (21 674 kg)	48,157 lb (21 844 kg)
Breakout force with tilt cylinder		50,409 lb (22 865 kg)	53,667 lb (24 343 kg)
Loader clearance circle with bucket		580.9 in (14 756 mm)	586.6 in (14 900 mm)

1121G		Z-Bar/XR	Z-Bar/XR
Maximum rollback:			
	Ground	44°/42°	45°/42°
	Carry position	49°/48°	49°/48°
	@ Full height	65°/66°	65°/66°
Maximum grading angle with bucket – back dragging		60°/62°	60°/62°
SAE bucket capacity – struck		5.45 yd ³ (4.17 m ³)	5.25 yd ³ (4.01 m ³)
Heaped		6.25 yd ³ (4.78 m ³)	6.10 yd ³ (4.66 m ³)
Bucket width – outside		125.8 in (3 195 mm)	126.9 in (3 223 mm)
Bucket weight		4,941 lb (2 241 kg)	4,937 lb (2 240 kg)

NOTE: *Z-Bar performance data shown w/ standard counterweight. Performance data unit equipped with 26.5-R25 L3 Radial tires, ROPS cab w/ heater and A/C, standard counterweight, full fuel and 165 lb (75 kg) operator. Specifications per SAE J732, J1234, J695, J742, and J818.

STANDARD EQUIPMENT

OPERATOR ENVIRONMENT

See page 1

ENGINE

CASE/FPT F2CFE614F
Tier 4 Final Certified
Selective Catalytic Reduction (SCR) with Diesel Oxidation Catalyst
Selectable work modes:
Maximum Mode
Smart Mode
Automatic shutdown – idle reduction device
Turbocharger
Charge air cooling
Automatic fan belt tensioner
Integral engine oil cooling
Fuel filter with water trap
Dual-element dry-type air cleaner
Hydraulic-driven cooling fan
Air-cooled radiator
Rear-mounted cooling module with hydraulically driven auto-reversing fan
Engine block heater
Sound suppression kit
Ejector type air precleaner
Common rail electronic fuel injection

LOADER

See page 2 – Operating weight,
Other specifications

DRIVETRAIN

4-wheel drive
4F/3R Selectable autoshift/manual shift transmission
Electronic Control Module – programmable, computer controlled proportional shifting with programmable gear selection
Onboard diagnostics
Heavy-duty axles with coolers:
With locking front differential and open/conventional rear differential
Single lever electronic shift control
F/N/R switch in loader control handle
Downshift button
Torque converter
Outboard planetary axles
Transmission oil cooler
Brake pedal transmission disconnect
Hydraulic wet disc brakes
Spring-applied hydraulic release parking brake
Limp-Home Mode
Greaseable rear axle trunnion

HYDRAULICS

Adjustable Electro-hydraulic – EH loader control with 3 configurable buttons
Adjustable EH settings:
Smooth
Moderate
Aggressive
Integrated Payload System
Ride Control™
EH Parallel Lift
Low-effort steering
Hydraulic driven fan
8 Diagnostic quick couplers
Split flange hydraulic connections – 1 inch or greater
Hydraulic oil cooler

ELECTRICAL

Battery isolator/electrical disconnect
120 amp alternator and voltage regulator
(2) 1000 CCA 12-volt batteries
Electric starter
Lights:
Integrated 4-corner strobe
Front and rear halogen flood lights
2 Front driving headlights – high/low beam
2 Front flood
2 Rear flood
2 LED stop and tail lights
Front and rear turn signal/flash
Key start/stop switch
Centrally located fuse box with all electrical circuits protected
Backup alarm
Remote jump start posts

OTHER

Electric hood lift
Front and rear fenders, partial coverage
External rear view mirrors
Standard counterweight
Drawbar hitch
Articulation locking bar
Lift arm locking bar
Lift and tie-down points – front/rear
Backup alarm
3-piece rims
Rear frame side covers
License plate brackets; front bracket and lit rear bracket
Rubber steering stops
Standard fenders with Left hand and Right hand steps
Grouped remote-mounted ecology drains:
Engine oil
Engine coolant
Hydraulic oil

TELEMATICS

CASE SiteWatch™ Telematics – includes hardware and a 3-yr Advanced data subscription
SiteConnect Module provides remote diagnostics capability

OPTIONAL EQUIPMENT

OPERATOR ENVIRONMENT

Leather trimmed heated air seat with active suspension
In cab powered cooler box
In cab accessory mount
Rear view camera
External heated rear view mirrors
Front LED driving/headlights
LED front and rear work lights – 4 front, 2 rear

DRIVETRAIN

Axle oscillation stops
Cold weather package:
Fuel heater
Hydraulic oil cooler bypass
Low temperature hydraulic oil

HYDRAULICS

Auxiliary hydraulics
Secondary steering
Tire Pressure Monitoring System
2-function EH loader control with one auxiliary function
4-function EH loader control with two proportional auxiliary controls
2 Single axis EH levers and one auxiliary function
Joystick steering with or without secondary steering

LOADER

XR extended reach version
Attachment auxiliary hydraulics
Buckets – see page 4

TIRES

26.5 x 25 L3 Bias
26.5-R25 L3 Radial
26.5 x 25 L5 Bias
26.5-R25 L5 Radial

OTHER

12 mph (20 kph) maximum speed control
Special paint
Wide full coverage fenders with right and left hand steps

CaseCE.com

©2022 CNH Industrial America LLC. All rights reserved. CASE is a trademark registered in the United States and many other countries, owned by or licensed to CNH Industrial N.V., its subsidiaries or affiliates. CNH Industrial Capital is a trademark in the United States and many other countries, owned by or licensed to CNH Industrial N.V., its subsidiaries or affiliates. Printed in U.S.A. Contains 10% post-consumer fiber.

Form No. CCE2022121121G
Replaces Form No. CCE2021041121G

IMPORTANT: CASE Construction Equipment Inc. reserves the right to change these specifications without notice and without incurring any obligation relating to such change. Availability of some models and equipment builds vary according to the country in which the equipment is used. The illustrations and text may include optional equipment and accessories and may not include all standard equipment. Your CASE dealer/distributor will be able to give you details of the products and their specifications available in your area.



CASE Construction Equipment is biodiesel-friendly. NOTE: All engines meet current EPA emissions regulations. All specifications are stated in accordance with SAE Standards or Recommended Practices, where applicable.



Always read the Operator's Manual before operating any equipment. Inspect equipment before using it, and be sure it is operating properly. Follow the product safety signs and use any safety features provided.

MIMICO

0800 64 64 26 | enquiries@mimico.co.nz | www.mimico.co.nz