

WASTE

MATERIAL HANDLERS



FUCHS[®]

A TEREX BRAND



COMPACT AND AGILE

➤ The MHL310 combines all advantages of a Fuchs material handling machine, without compromises. Up to 29'6" reach, high-performance cooling systems, closed slewing drive, a unique service platform, and much more. A great and compact package.

Fuchs MHL310 F

Engine Power: 114 hp
Operating Weight w/o Attachments: 32,188–37,699 lbs
Reach: max. 29'6"

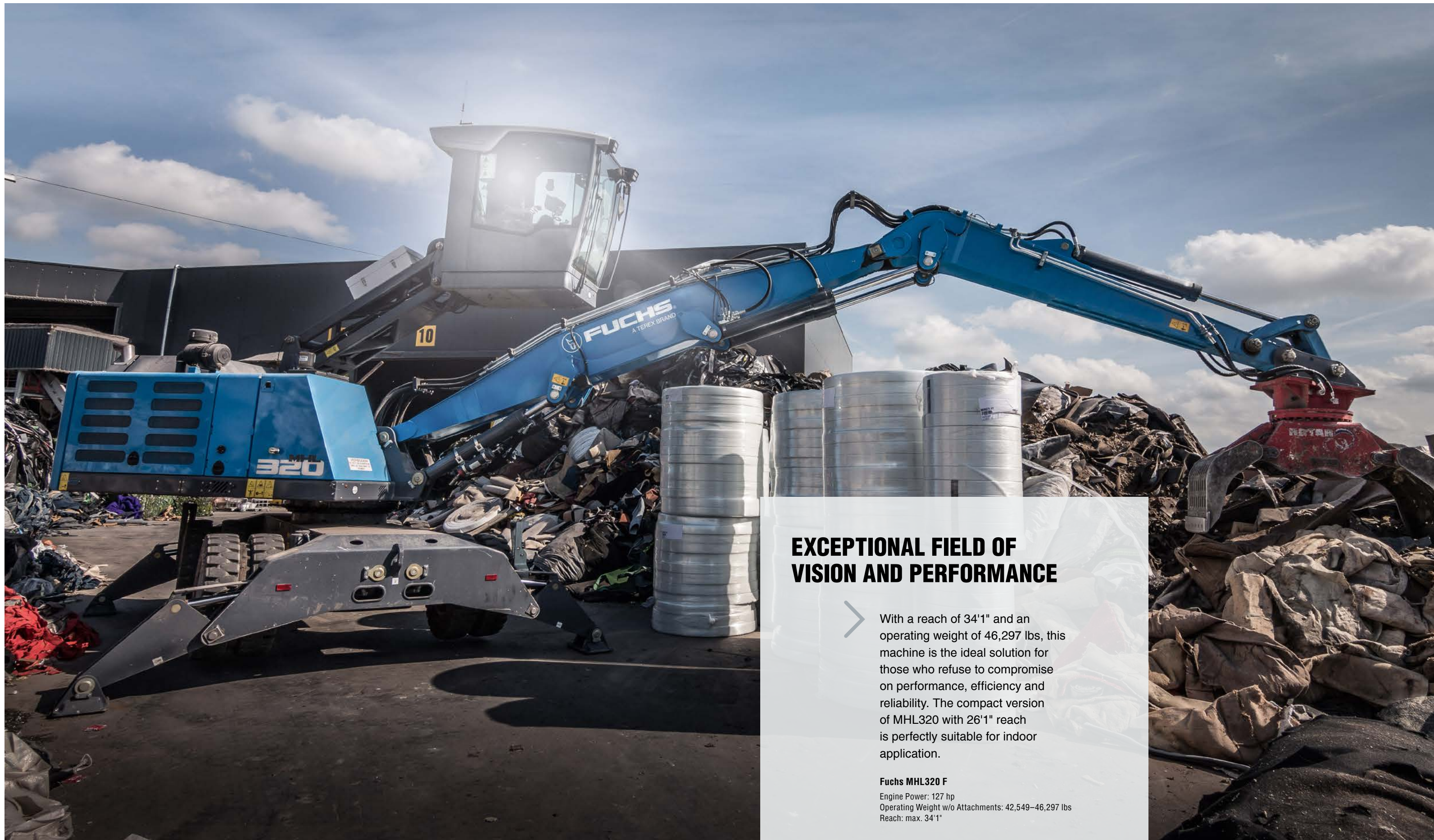

EXCEPTIONAL FIELD OF VISION AND PERFORMANCE

➤ With a reach of 34'1" and an operating weight of 46,297 lbs, this machine is the ideal solution for those who refuse to compromise on performance, efficiency and reliability. The compact version of MHL320 with 26'1" reach is perfectly suitable for indoor application.

Fuchs MHL320 F

Engine Power: 127 hp
Operating Weight w/o Attachments: 42,549–46,297 lbs
Reach: max. 34'1"



MORE POWER AND REACH WHILE RETAINING COMPACT DIMENSIONS

➤ With its substantial reach of 39'4" and high load capacity, the MHL331 is one of the top recycling models in the world. The MHL331 is the optimal solution for loading containers, shredders and walking floors.

Fuchs MHL331 F

Engine Power: 154 hp
Operating Weight w/o Attachments: 50,264–53,351 lbs
Reach: max. 39'4"



THAT EXTRA BIT OF STABILITY

The Fuchs MHL335 combines the advantages of the Fuchs MHL331 with an enlarged undercarriage for exceptional stability at maximum load and reach.

Fuchs MHL335 F

Engine Power: 154 hp
Operating Weight w/o Attachments: 52,691–56,217 lbs
Reach: max. 39'4"

WELL-THOUGHT-OUT MACHINE FOR MORE POWER AND REACH

Highly efficient dual-circuit hydraulics ensure that slewing manoeuvres are as swift and powerful as they are precise. Providing a 44'11" reach and an excellent eye level up to 5.6 m makes the MHL340 a top performer in its class.

Fuchs MHL340 F

Engine Power: 173 hp

Operating Weight w/o Attachments: 62,611–67,461 lbs

Reach: max. 44'11"



ATTACHMENTS AND LOADING EQUIPMENT

- Universal stick for sorting grapples
- Dipperstick for cactus or clamshell grab
- Grab rotation speed and pressure regulation
- Optimally arranged hydraulic pipes and hoses

CABIN

- Hydraulically adjustable cab
- Large skylight
- Sliding window in cab door
- Safety glass
- Automatic air conditioning system

UPPERCARRIAGE

- Separated cooling system for engine, hydraulic oil cooler and AC condenser
- Rear and side view camera
- Temperature-controlled fan drives
- Highly energy-efficient

UNDERCARRIAGE

- Mobile, crawler or stationary

SERVICE PLATFORM

- Comfortable access to engine, main hydraulic valve block, diesel, DEF tank etc.
- Safe place for service
- Unique in the market

ENGINE

Diesel engine

- Best-in-class for fuel consumption economy in its power segment
- Latest EU-Stage V emission technology
- ROW solutions
- Covered and protected EAT system

Electric motor

- Low maintenance, and operating costs
- Low noise
- Zero local emissions



GREAT FEATURES COME STANDARD WITH YOUR FUCHS



AIR-CUSHIONED COMFORT SEAT

with integrated headrest, safety belt and lumbar support

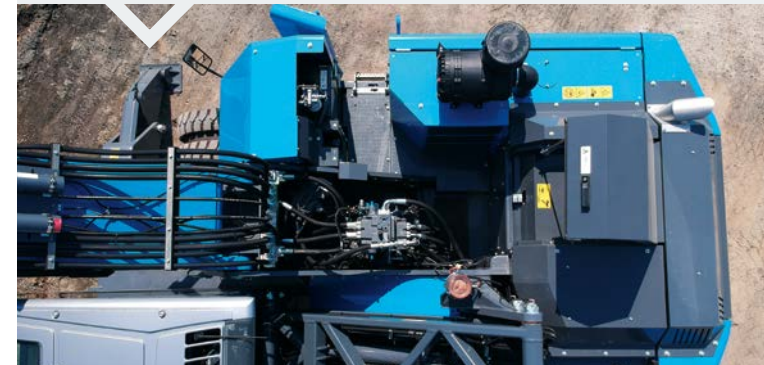

FUCHS SERVICE PLATFORM

safe place for daily checks and maintenance



SEPARATE COOLING SYSTEM

for engine and hydraulic oil cooler



REVERSING FAN

for more cooling performance and less dirt and debris in intercooler, water and oil-cooler

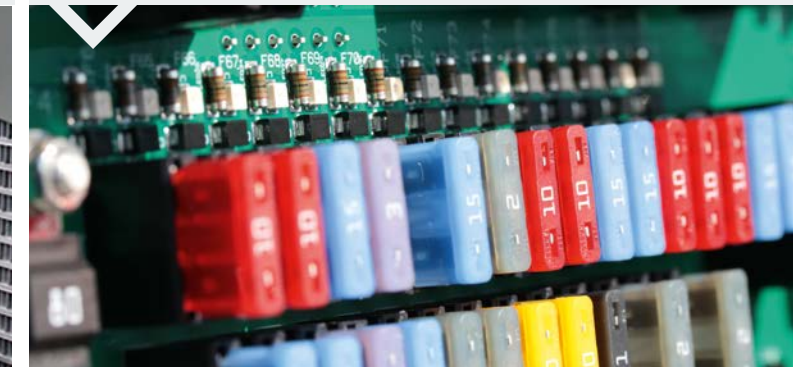

QUICK FUSE CHECK BUTTON

makes it quick and easy to check the fuses of your Fuchs

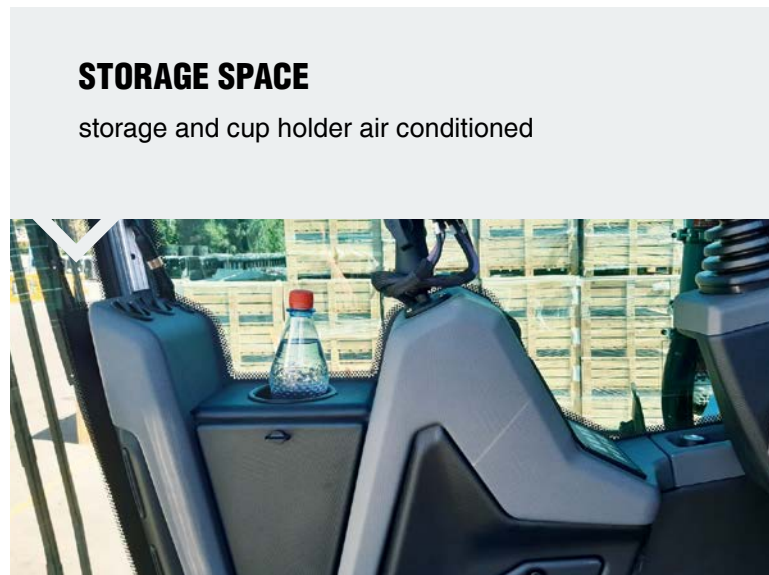

STORAGE SPACE

storage and cup holder air conditioned



DIGITAL DISPLAY

with large dimensions provides great overview and info at a glance



OIL PRESSURE AND VOLUME ADJUSTMENT

makes it easy to adapt speed of grab rotation (stepless or black & white)



AUTOMATED GREASING SYSTEM

ensures key components running smoothly

SPECIAL OPTIONS FOR WASTE APPLICATIONS



BOOM CYLINDER DAMPING SYSTEM

for smooth operations

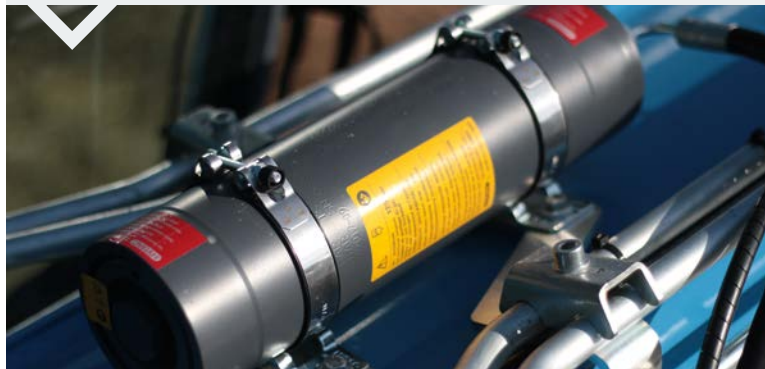

DOZER BLADE

in addition to 4-point stabilizers allows to push material



SUPPORT BLADE AND 2-POINT STABILIZERS

ALL-WHEEL-STEERING

reduction of the turning circle by 35%, exceptional manoeuvrability, USP

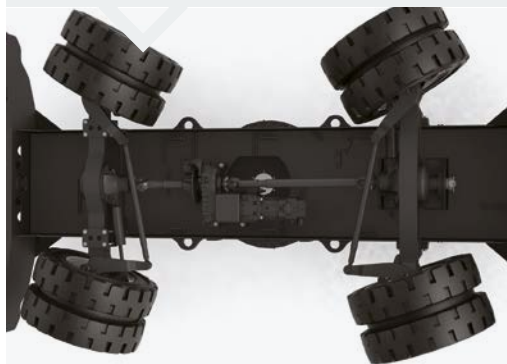

OVERLOAD AND WORK AREA CONTROL

easy teach in, great for indoor application

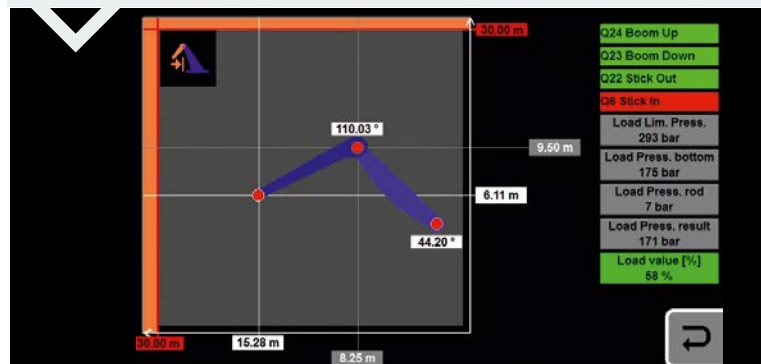

UNIVERSAL STICK

when it comes to precise sorting

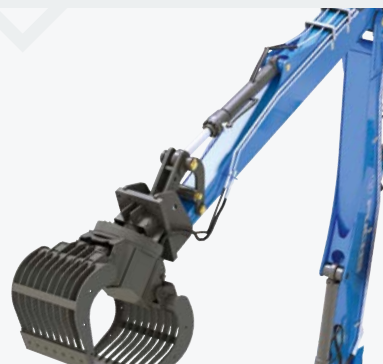

HIGH PRESSURE FILTRATION SYSTEM FOR ATTACHMENTS

effective protection against contamination of hydraulic oil from damaged or leaking attachments



ELECTRIC DRIVEN MATERIAL HANDLER

Electric drives are today's forward-looking trend. This is especially the case with indoor applications, stationary machines, and machines with rail undercarriage, in which powerful zero-emission electric drives that are extremely easy to maintain have very tangible advantages. They include low operating and servicing costs, low noise emissions and heat build-up, and the extensive use of standard components from our range of diesel engine models, which ensures that spare parts will be widely available.

The right connection, every single time: the cable lengths and cable reel designs of Fuchs electric machines are adapted to each customer's specific needs in line with the required reach and the available connection options on site.

Thanks to the Power Pack users of electric driven material handlers can enjoy even greater flexibility. The Power Pack allows electric driven material handlers to be driven from one power socket to the other independently of any external electricity supply. This is made possible by an integrated diesel-powered hydraulic unit.

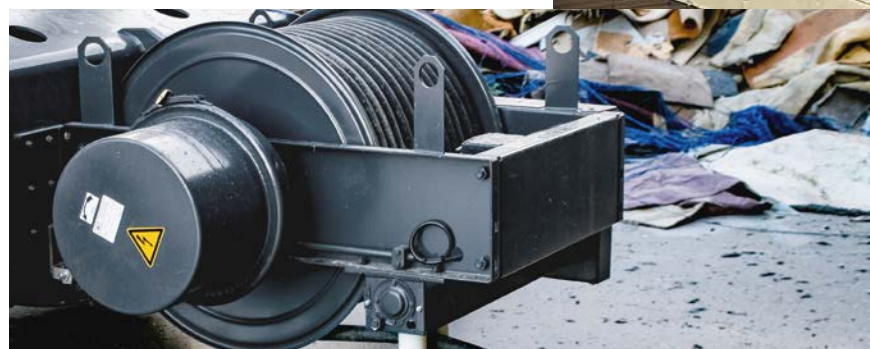

ZERO EMISSION

> No exhaust gases, little noise and very little heat output: ideal features when operating indoors or close to residential areas



THE PERFECT FUCHS MATERIAL HANDLERS FOR YOUR RECYCLING PROCESSES

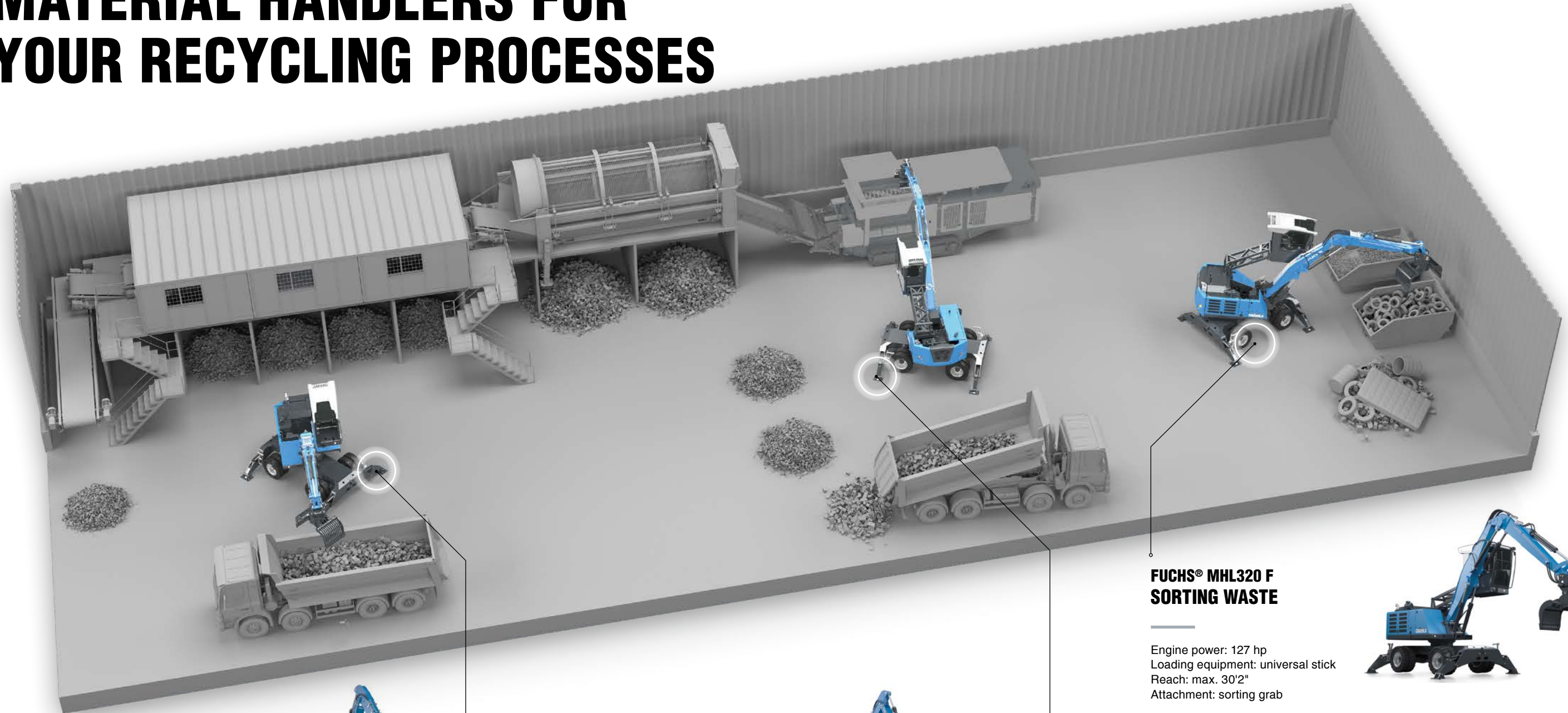

FUCHS® MHL310 F LOADING A TRUCK

Engine power: 114 hp
Loading equipment: universal stick
Reach: max. 28'10"
Attachment: sorting grab



FUCHS® MHL310 F FEEDING A SHREDDER

Engine power: 114 hp
Loading equipment: universal stick
Reach: max. 28'10"
Attachment: sorting grab

FUCHS® MHL320 F SORTING WASTE

Engine power: 127 hp
Loading equipment: universal stick
Reach: max. 30'2"
Attachment: sorting grab



MAKE YOUR RECYCLING PROCESSES RUN SMOOTHLY

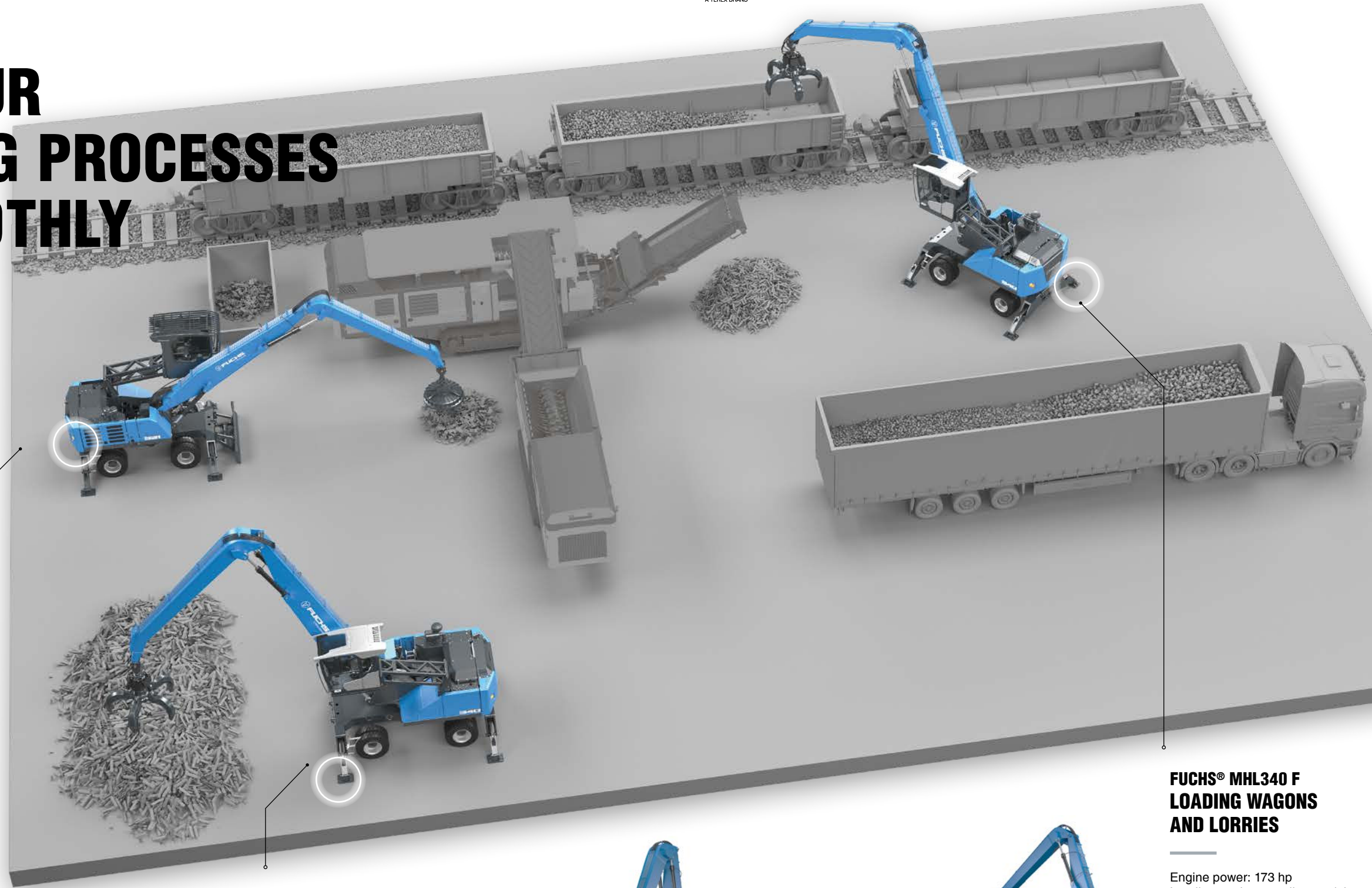

FUCHS® MHL331 F SORTING OF SCRAP WASTE

Engine power: 154 hp
Loading equipment: dipper stick
Reach: max. 39'4"
Attachment: magnet plate

FUCHS® MHL340 F FEEDING A SHREDDER

Engine power: 173 hp
Loading equipment: dipper stick
Reach: max. 44'11"
Attachment: cactus grab



FUCHS® MHL340 F LOADING WAGONS AND LORRIES

Engine power: 173 hp
Loading equipment: dipper stick
Reach: max. 44'11"
Attachment: cactus grab



MHL310



114 hp



75 kW



32,188–
37,699 lbs



17'5"

Loading equipment

- with dipperstick 29'6"
- with universal stick 28'10"

Turning radius

- without all-wheel steering 23'4"
- with all-wheel steering 14'9"

Undercarriage mobile

- 4-point stabilizers
- dozer blade in addition to 4-point stabilizers
- 2-point stabilizers and support blade



Engine power
EU-Stage V



Electric motor



Max. service weight
without attachments



Max. viewing height





**DESIGNED FOR USE IN
CONFINED SPATIAL CONDITIONS**

All-wheel steering (optional) reduces the turning circle by up to 35%. Assistance systems like the handy height and reach limit ensure elevated safety for material handling in low halls. A short rear-end radius minimizes the risk of collision when slewing.



CLOSED SLEWING DRIVE

Agile slewing increases productivity and energy efficiency. The enclosed slewing gear simultaneously holds more capacity for the boom and dipper stick—**unique in this class.**



MHL320



127 hp



75 kW



46,297 lbs



17'4"

Loading equipment

- with dipperstick 31'2" / 34'1"
- with universal stick 26'10" / 30'2"

Turning radius

- without all-wheel steering 23'3"
- with all-wheel steering 14'9"

Undercarriage mobile

- 4-point stabilizers
- dozer blade in addition to 4-point stabilizers
- 2-point stabilizers and support blade



- 5 Engine power EU-Stage V
- 3 Engine power EU-IIIa / EPA-Tier 3
- Electric motor
- Max. service weight without attachments
- Max. viewing height



PRECISE SORTING WORK

The universal stick with a reach of 30'2" is fitted with lifting cylinder cushioning as standard. In conjunction with the precise hydraulics, the driver can perform sorting work with extreme accuracy.

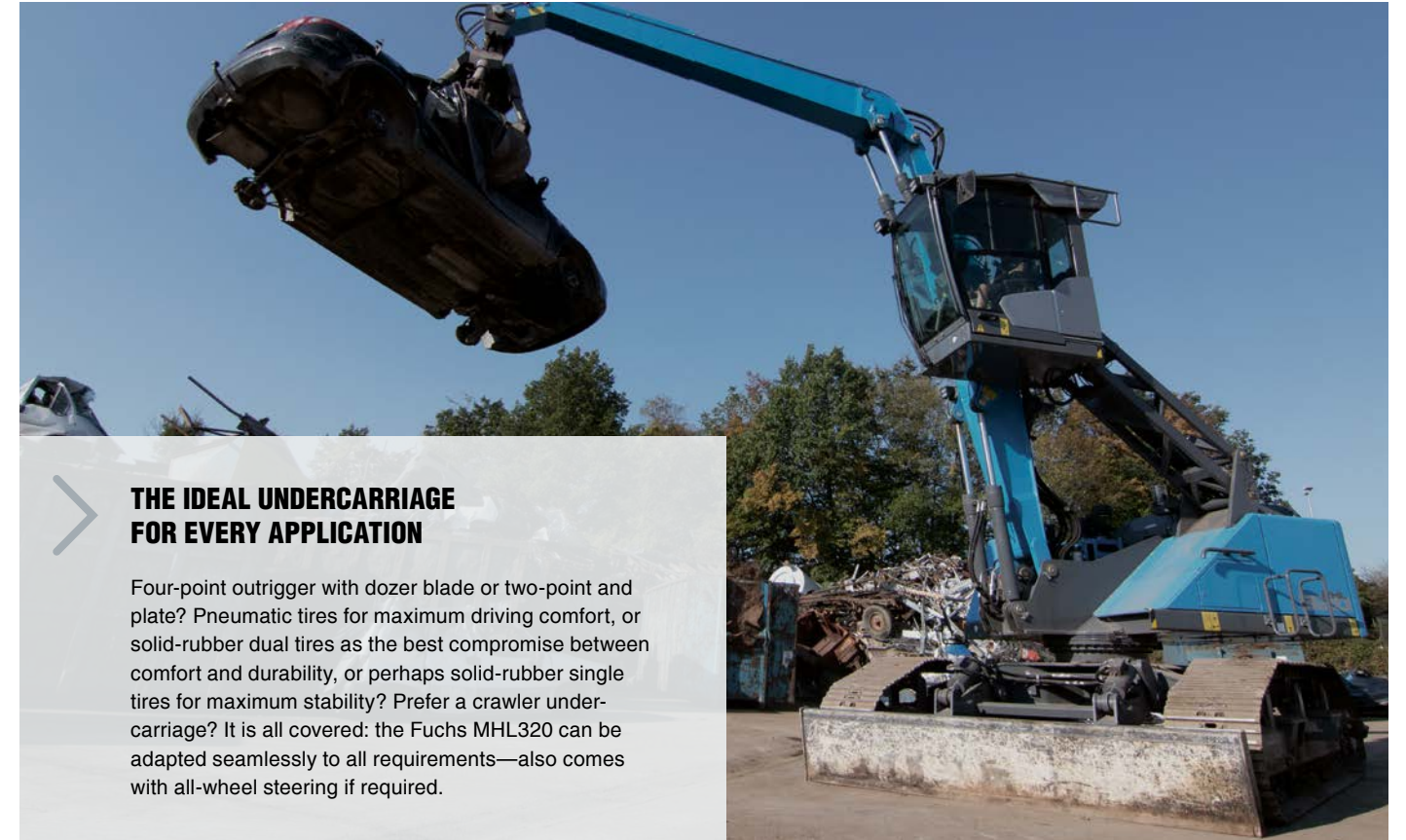

➤ **THE IDEAL UNDERCARRIAGE FOR EVERY APPLICATION**

Four-point outrigger with dozer blade or two-point and plate? Pneumatic tires for maximum driving comfort, or solid-rubber dual tires as the best compromise between comfort and durability, or perhaps solid-rubber single tires for maximum stability? Prefer a crawler undercarriage? It is all covered: the Fuchs MHL320 can be adapted seamlessly to all requirements—also comes with all-wheel steering if required.

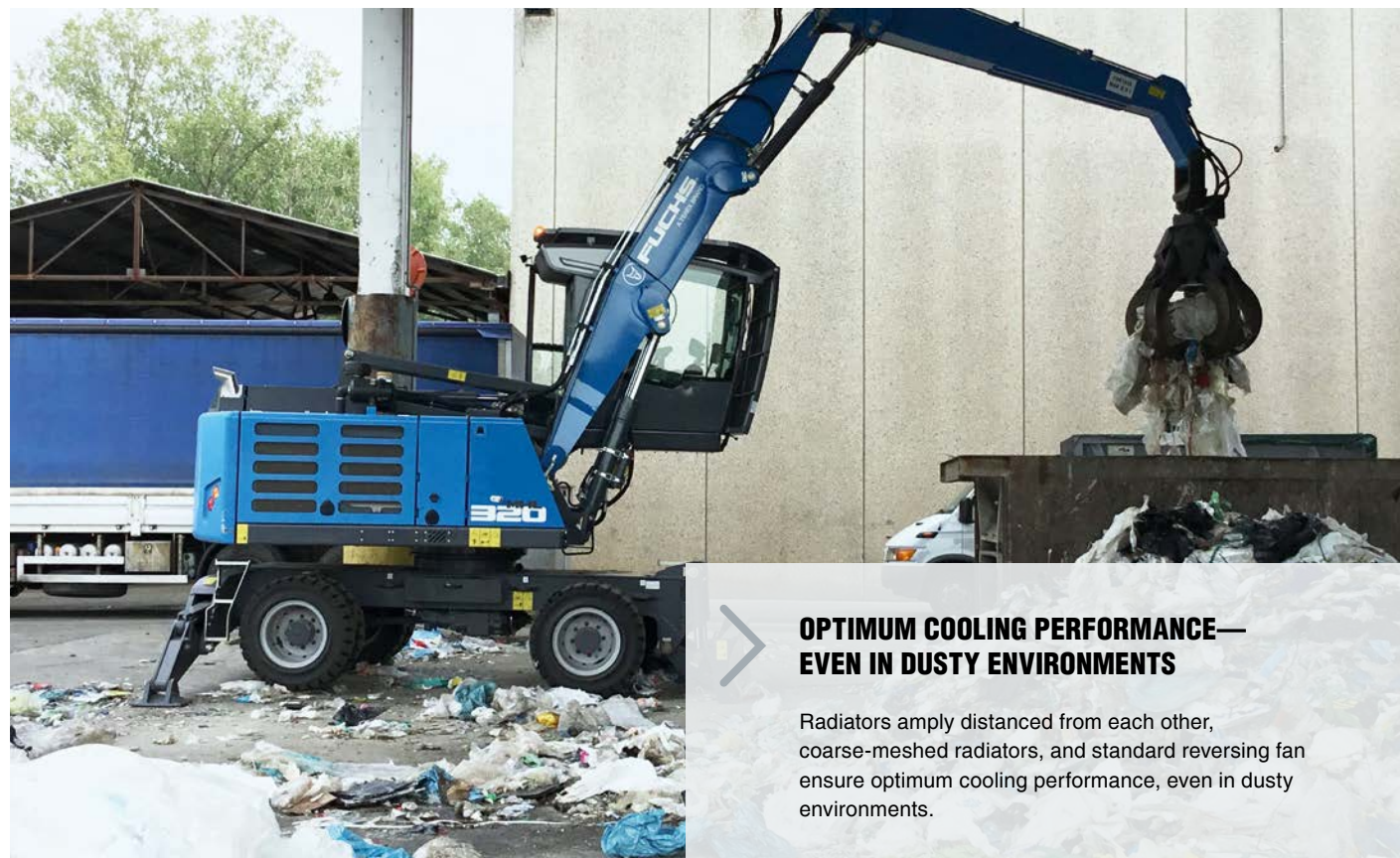

➤ **OPTIMUM COOLING PERFORMANCE—EVEN IN DUSTY ENVIRONMENTS**

Radiators amply distanced from each other, coarse-meshed radiators, and standard reversing fan ensure optimum cooling performance, even in dusty environments.



MHL331



154 hp



90 kW



53,351 lbs



17'4"

Loading equipment

- with dipperstick 36'1" / 39'4"
- with universal stick 35'1"

Turning radius

- 25'11"

Undercarriage mobile

- 4-point stabilizers
- dozer blade in addition to 4-point stabilizers
- 2-point stabilizers and support blade



Engine power
EU-Stage V



Engine power
EU-IIIa / EPA-Tier 3



Electric motor



Max. service weight
without attachments



Max. viewing height



COMPACT AND POWERFUL

The Fuchs MHL331 impresses with a maximum reach of 39'4". The efficient diesel engine ensures the necessary power, while the exhaust cleaning system keeps emissions extremely low. As with all Fuchs material handlers, this machine can also be supplied as a zero-emission model with electric drive.



**ENVIRONMENTALLY-FRIENDLY,
ECONOMICAL AND RELIABLE**

- The electrically driven Fuchs MHL831 provides:
- equivalent performance to conventional machines
 - lower total cost of ownership
 - low operating noise—what is ideal for sensitive areas such as interior spaces



**THE UNDERCARRIAGE FOR
PROFESSIONAL MATERIAL
HANDLING IN SMALL SPACES**

The Fuchs MHL331 sits on very solid 8'2" axles. Thanks to the compact design of the undercarriage, it deals with tight passages like child's play.



MHL335



154 hp



90 kW



56,217 lbs



17'4"

Loading equipment

- with dipperstick 36'1" / 39'4"
- with universal stick 35'1"

Turning radius

- 26'10"

Undercarriage mobile

- 4-point stabilizers
- dozer blade in addition to 4-point stabilizers



Engine power
EU-Stage V



Engine power
EU-IIIa / EPA-Tier 3



Electric motor



Max. service weight
without attachments



Max. viewing height



PURPOSE BUILT LOADING EQUIPMENT

The loading equipment with universal stick and 35'1" reach enables precise sorting work to the farthest angle. The standard lifting cylinder cushioning reduces the vibrations of the loading equipment considerably and simplifies loading operations.



MHL340



173 hp



110 kW



67,461 lbs



18'4"

Loading equipment

- with dipperstick 41'4" / 44'11"
- with universal stick 40'

Turning radius

- 27'2"

Undercarriage mobile

- 4-point stabilizers
- dozer blade in addition to 4-point stabilizers



Engine power
EU-Stage V



Engine power
EU-IIIa / EPA-Tier 3



Electric motor



Max. service weight
without attachments



Max. viewing height



ALL-ROUNDER

Whether it is domestic, industrial or municipal waste, C&D, or scrap: our Fuchs MHL340 is the perfect choice for (almost) all demands.



ONE OF THE MOST EFFICIENT COOLING SYSTEMS

Radiators physically separated from each other, temperature-controlled fans, including reversing function, and direct air flow without sandwich designs: this is standard in all Fuchs loading machines.

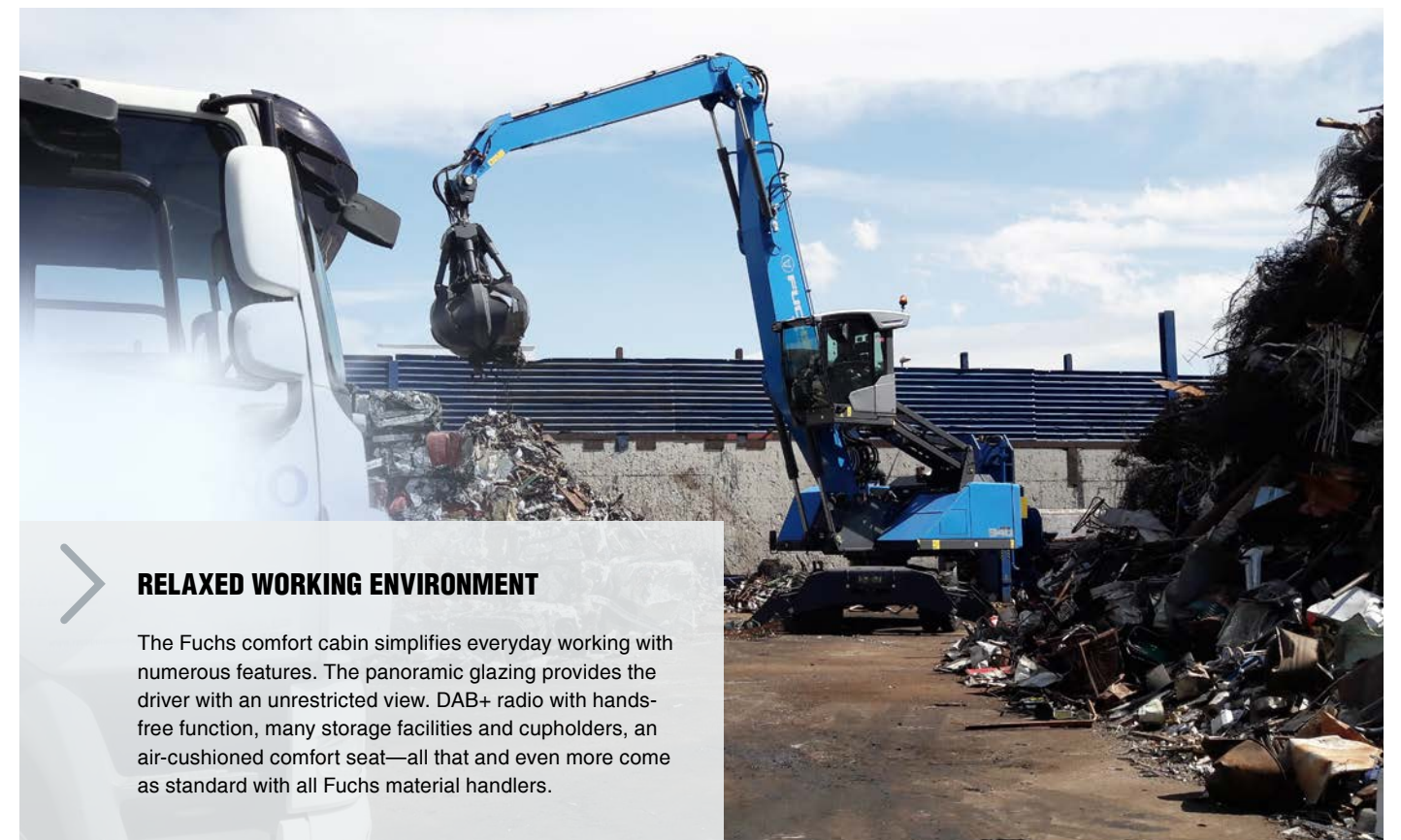

RELAXED WORKING ENVIRONMENT

The Fuchs comfort cabin simplifies everyday working with numerous features. The panoramic glazing provides the driver with an unrestricted view. DAB+ radio with hands-free function, many storage facilities and cupholders, an air-cushioned comfort seat—all that and even more come as standard with all Fuchs material handlers.

SAFETY FEATURES



CLOSE RANGE SHUT-OFF SYSTEM

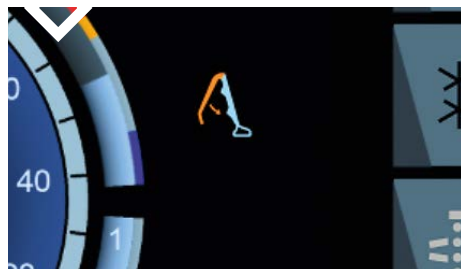

BLOCKING OF DRIVE AND WORK FUNCTIONS

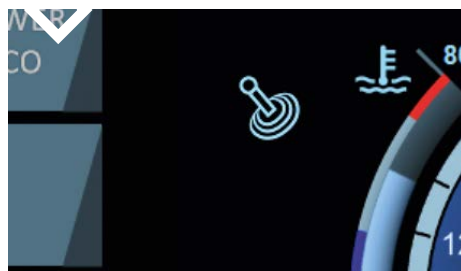

OVERLOAD WARNING DEVICE*



OVERLOAD AND WORK AREA CONTROL*



CATWALK WITH HANDRAIL*



SERVICE PLATFORM



KEY-LOCKABLE SWITCH FOR DISCONNECTION OF THE ELECTRICAL ENERGY



CABIN COMFORT ACCESS*



ADDITIONAL STEPS AT THE FRONT AND REAR OF UNDERCARRIAGE*



*Option

MODULAR SYSTEM

ATTACHMENTS



Cactus grab Timber grapple Magnet plate Clamshell grab Load hook Sorting grapple

WORK EQUIPMENT

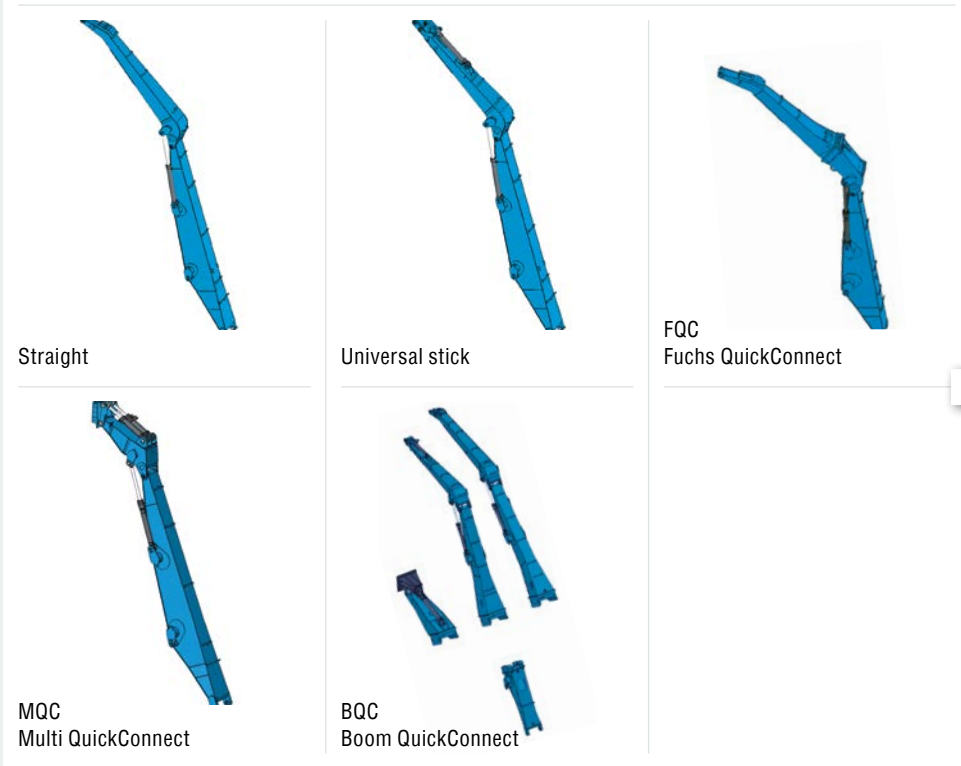

Straight Universal stick FQC Fuchs QuickConnect MQC Multi QuickConnect BQC Boom QuickConnect

CAB SYSTEMS

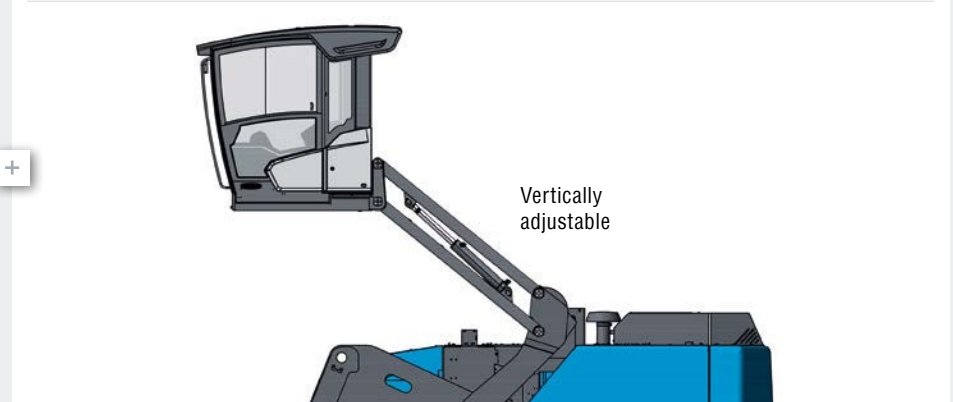

Vertically adjustable

ENGINES

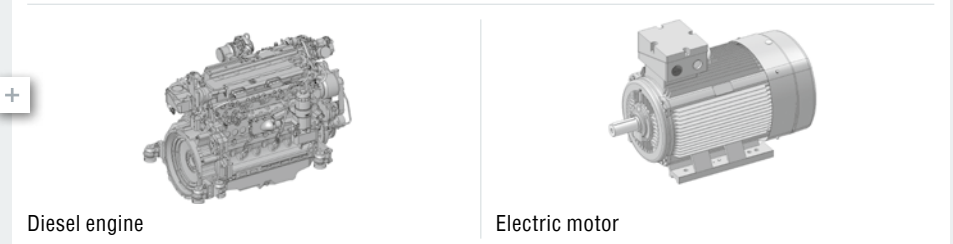

Diesel engine Electric motor

OPTIONS

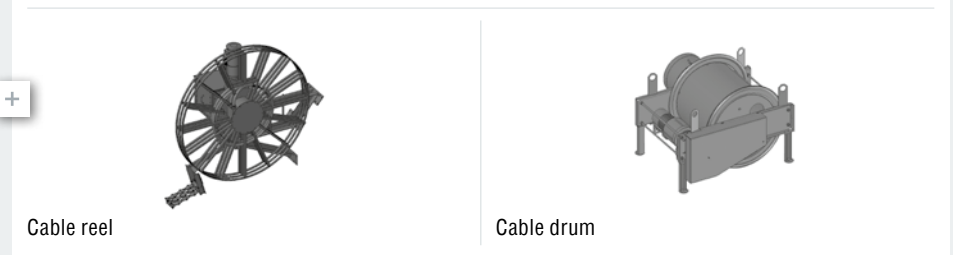

Cable reel Cable drum

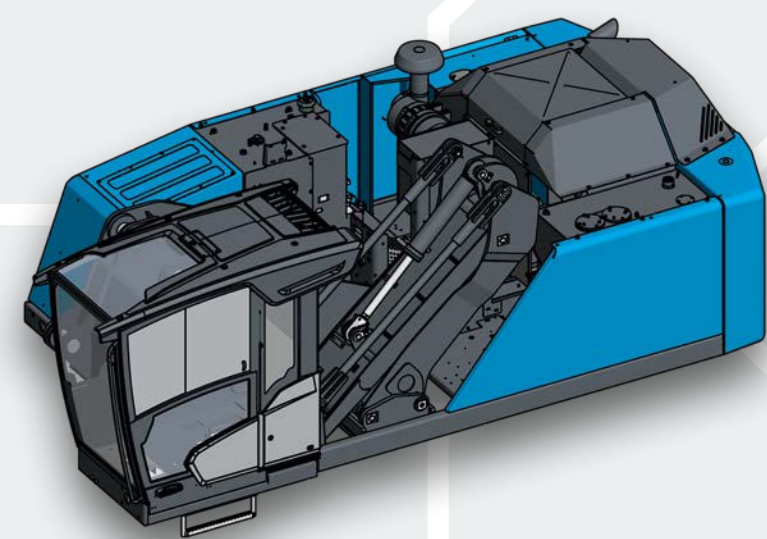

UNDERCARRIAGES



Standard-undercarriage Standard-undercarriage 2'7" Standard-undercarriage 4'7" XL-undercarriage Crawler Crawler 2'7" AHL Standard-undercarriage 2'7"-9'10" AHL Pylon 1'11"-9'10"



WORKS FOR YOU.™

www.terex-fuchs.com

May 2020. Product specifications and prices are subject to change without notice or obligation. The photographs and/or drawings in this document are for illustrative purposes only. Refer to the appropriate Operator's Manual for instructions on the proper use of this equipment. Failure to follow the appropriate Operator's Manual when using our equipment or to otherwise act irresponsibly may result in serious injury or death. The only warranty applicable to our equipment is the standard written warranty applicable to the particular product and sale and Terex makes no other warranty, express or implied. © Terex Corporation 2020 - Terex, the Terex Crown design, Fuchs and Works For You are trademarks of Terex Corporation or its subsidiaries.

Fuchs USA | 11001 Electron Drive | Louisville, KY 40299 | USA | Phone: +1 502 640 6001 | sales.fuchsus@terex.com

