

TECHNICAL DATA



MHL 354 & 364



FUCHS®



A TEREX BRAND

MHL354 F

-  **160 kW**
-  **32–34.9 t**
-  up to **11.3 m**

Page **04**

MHL364 F

-  **190 kW**
-  **45–48.1 t**
-  up to **12.1 m**

Page **08**





MHL354

TECHNICAL DATA

SERVICE WEIGHT WITHOUT ATTACHMENT

MHL354 F	32–34.8 t
----------	-----------

DIESEL ENGINES

	EU Stage V / U.S. Tier 4	EU Stage IIIA / U.S. Tier 3 *
Manufacturer & model	Deutz TCD 6.1 L6	Deutz TCD2013 L06
Type	6-cylinder inline	6-cylinder inline
Engine operation	4-stroke engine, direct common-rail fuel injection, turbocharger with charge air intercooling, controlled exhaust gas recirculation, diesel particle filter with a continuously regenerating system and SCR catalytic converter	4-stroke engine, direct common-rail fuel injection, turbocharger with charge air intercooling
Power	160 kW	148 kW
Nominal speed	2,000 rpm	2,000 rpm
Displacement	6.1 l	7.2 l
Cooling system	Water / charge air cooling with temperature-controlled fan speed	Water / charge air cooling with temperature-controlled fan speed
Exhaust emission standard	EU Stage V / U.S. Tier 4	EU Stufe IIIA / U.S. Tier 3 *
Fuel tank	315 l	315 l
DEF tank	32 l Ad Blue	—

ELECTRICAL SYSTEM

Alternator	28 V / 100 A
Voltage	24 V
Batteries	2 × 12 V / 110 Ah / 750 A (in accordance with EN)
Lights	2 × LED floodlights at the front of the machine, rear parking lights and indicator lights

HYDRAULIC SYSTEM

Cooling system	Separated high-performance cooler with temperature-dependent fan drive
Hydraulic oil filter	Flow-optimized return filters, integrated in the oil tank. Filter fineness defined at a beta value $\beta(10) = 200$ guarantees 99.5% separation of dirt particles with 10 μm . Very good separation values are already achieved with particle sizes of 3 μm . Generously dimensioned for long operating times.
Max. pump flow	2 × 330 l/min
Max. pressure	320 / 360 bar
Hydraulic tank	366 l

BRAKES

Service brake	Hydraulically activated single circuit brake system that works on all four pairs of wheels
Parking brake	Electro-hydraulically actuated spring-loaded disk brake on the front axle, works on both axles

TRAVEL DRIVE

Hydrostatic drive through infinitely variable axial piston motor with directly mounted travel brake valves, two-speed shift gear, 4-wheel drive	
Travel speed	1st gear: max. 6 km/h 2nd gear: max. 20km/h
Turning radius	5.7 m

SLEWING GEAR

Slewing ring	Internally geared double row slewing ring bearing, greasing via automatic lubrication system
Drive	3-stage planetary gear with integrated multi-disc brake
Swing speed	Infinitely variable from 0–7 rpm
Swing brake	Electrically operated

UNDERCARRIAGE

Front axle	Planetary drive axle with integrated drum brake, rigidly mounted, max. steering angle 29°
Rear axle	Planetary drive axle with integrated drum brake, selfaligning bearing with automatic oscillating lock, max. steering angle 29°
Stabilization	Support blade with integrated cylinder protection on side of oscillating axle
Tires	Pneumatic tires, 8-fold 10.00-20

OPERATOR'S CAB

Cab	Reinforced steel structure, soundproofed, heat-insulated panoramic windows for best all-round visibility, front window with roller blind, glass panel in the cabin roof with sliding blind. Heating and air conditioning, separate heat exchangers, fresh and recirculated air filters. Multifunction touch display, bottle holder, paper clip and multiple storage and mounting options. Digital radio (DAB+, USB, Bluetooth and hands-free), USB charging station 5V.
Air-conditioning	Automatic air-conditioning. Infinitely variable heating with 8-speed fan, 10 adjustable air nozzles, 3 defroster nozzles.
Operator's seat	Air-cushioned comfort seat with swinging armrests / joysticks, safety belt, lumbar support and headrest. Enables fatigue-free work due to universal adjustment options for the seat position, seat inclination and the arrangement of the seat cushion in relation to the armrests and joysticks.
Monitoring	Ergonomically arranged, glare-free Multifunction display. Automatic monitoring and storage of deviating operating states (e.g. all hydraulic oil filters, hydraulic oil temperature – coolant and charge air temperature – diesel particulate filter loading, steering), visual and audible warning. Diagnostic option for the individual sensors via the multifunction display. Rear view and side view camera on the right with separate monitor
Noise level EU Stage V / U.S. Tier 4	Sound power level (ambience) LWA 98.8 dB(A) (metered) acc. to directive 2000/14/EC LWA 101 dB(A) (guaranteed) acc. to directive 2000/14/EC Sound pressure level (inside the cabin) acc. to directive ISO 6396 LpA 67 dB(A)
EU Stage IIIA / U.S. Tier 3*	LWA 101.3 dB(A) (metered) acc. to directive 2000/14/EC LWA 102 dB(A) (guaranteed) acc. to directive 2000/14/EC Sound pressure level (inside the cabin) acc. to directive ISO 6396 LpA 67 dB(A)
Vibrations	Weighted r.m.s. value of acceleration of upper limbs under 2.5 m/s ² (98 in/s ²) Weighted effective value of acceleration for the seat and feet under 0.5 m/s ² (20 in/s ²)

Certification in accordance with CE guidelines

* for low-regulated markets

EQUIPMENT

ENGINE

	Standard	Option
Intercooler and coolant radiator	●	
Direct electronic fuel injection/common rail	●	
Advanced automatic idle incl. engine shut-off function	●	
Engine preheating		●
Engine diagnostics interface	●	
Temperature-dependent fan drive	●	

UNDERCARRIAGE

Support blade on side of oscillating axle; integrated cylinder protection	●	
All-wheel drive	●	
Rear axle oscillating lock	●	
Special paint		●
Drum brakes	●	
Toolbox, small	●	
Toolbox, large		●
Access	●	
Fenders		●
Additional support blade		●

UPPERCARRIAGE

Separated high-performance cooling system	●	
Hydraulic oil cooler with temperature-dependent fan drive	●	
Fan drive reversing function		●
Lockable maintenance hatches, with gas struts	●	
Automatic central lubrication system	●	
Rear view camera	●	
Side view camera	●	
Travel alarm		●
Electric refuelling pump		●
Lighting protection		●
Special paint (customer paint work)		●
Cyclone prefilter		●

CAB

	Standard	Option
Single-pane safety glass (ESG)	●	
Sliding window in cab door	●	
Roof window clear glass	●	
Cabin with penetration resistant glass front and top (classification P5A)		●
Cabin with bullet-proof glass (classification P8B)		●
Windshield washer system	●	
Washing device for roof window		●
Air-cushioned operator seat with headrest, seatbelt, and lumbar support	●	
Seat heating		●
Joystick steering	●	
Steering column, height and tilt adjustable		●
Automatic air conditioning system	●	
Independent heating system		●
Multi-function display	●	
Document clip	●	
Protective grilles to front and roof		●
12V transformer		●
Digital radio (DAB+, USB, Bluetooth and hands-free system)	●	
12V socket / cigarette lighter	●	
Fire extinguisher, dry powder		●

EQUIPMENT

Close proximity range limiter for dipperstick	●	
Coolant and hydraulic oil level monitoring system	●	
Filtration system for attachments		●
Hose rupture valve for boom cylinder		●
Hose rupture valve for stick cylinder		●
Overload and work area control		●
Overload warning device		●
Quick coupling on dipperstick	●	
Dipperstick impact protection		●
Active cyclone prefilter (TOP AIR)		●
Hydraulic oil preheating 230 V		●
Float switch for barge unloading		●
Lubrication of the grab suspension by central lubrication system	●	
Light packages LED		●
LED front headlights	●	
Fuchs Connect telematics system, incl. 5 years contract	●	

Further optional equipment available on request!



DIMENSIONS MHL354

All dimensions in mm

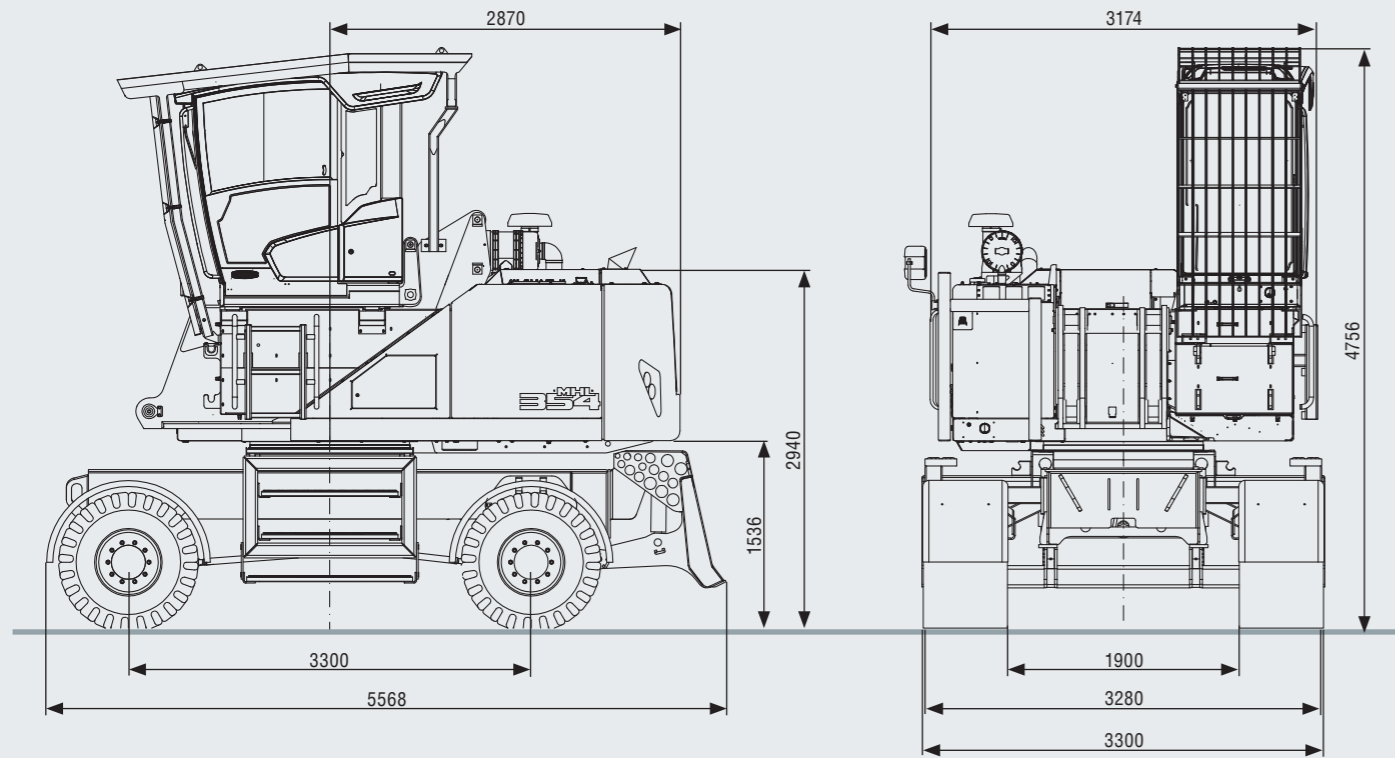

TRANSPORT DIMENSIONS MHL354

All dimensions in mm

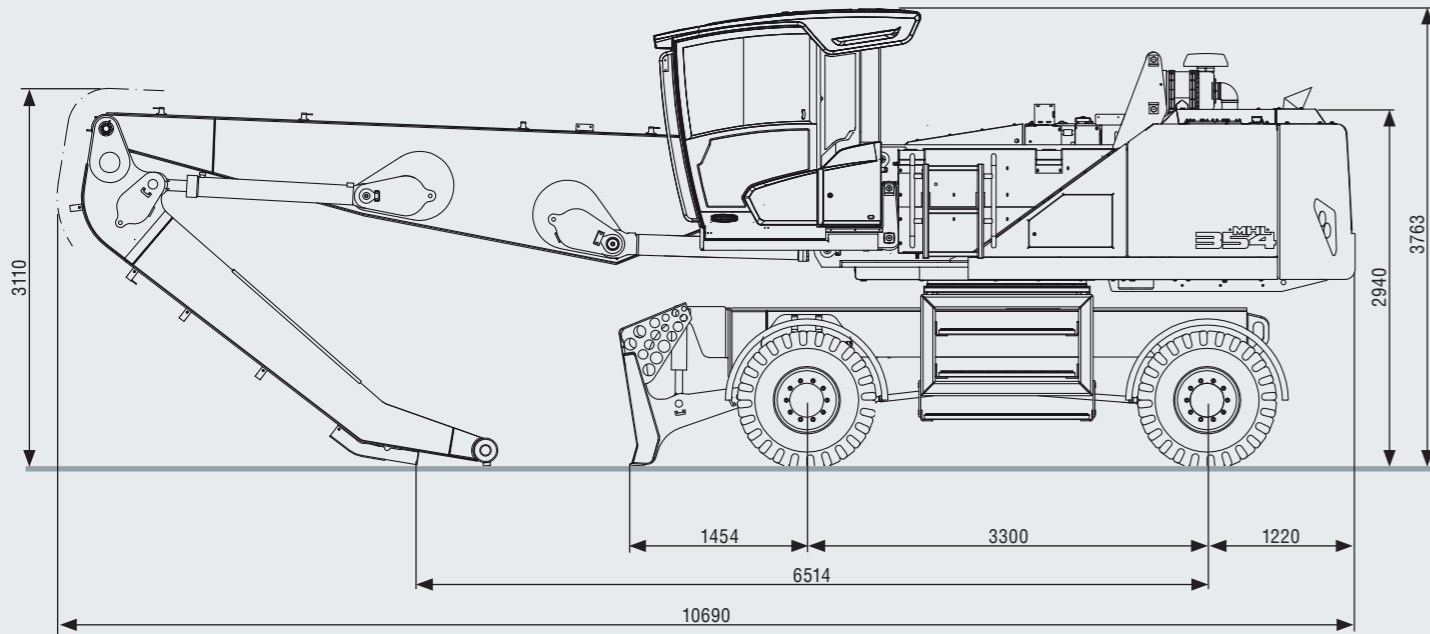

WORKING RANGE MHL354

REACH 11.3 M WITH DIPPER STICK

Loading equipment	Boom 6.4 m
	Dipper stick 4.1 m
	Multi-tine grapple

RECOMMENDED ATTACHMENTS

Grab size	1.75–2.5 m ²
	Depending on mission requirements

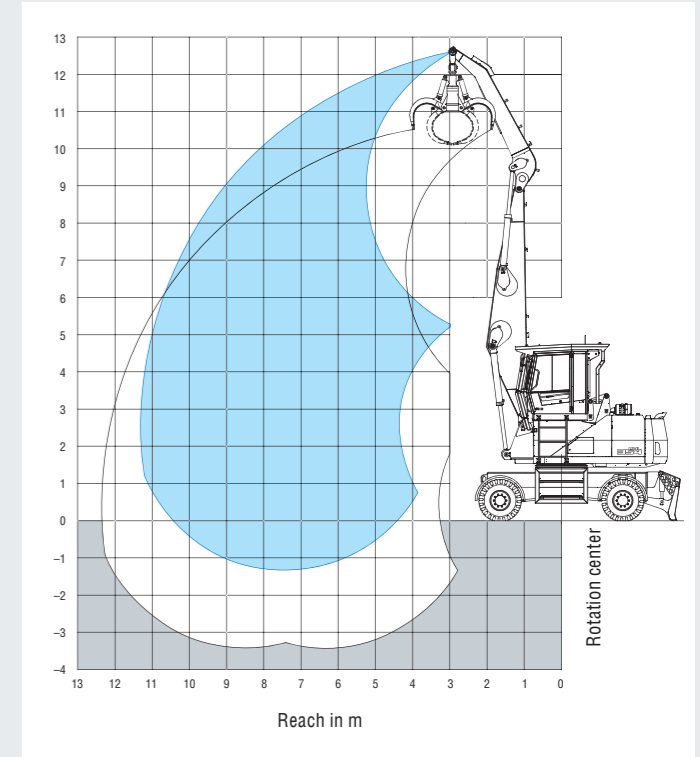

The lift capacity values are stated in metric tons (t). The pump pressure is 360 bar. In accordance with ISO 10567 the lift capacity values represents 75% of the static tipping loads or 87% of the hydraulic lifting force (marked °). On solid and level ground the values apply to a swing range of 360°. The (...) values apply in the longitudinal direction of the undercarriage. The values for "not supported" only apply via the steering axle or the locked oscillating axle. The weights of the attached load hoisting equipment (grab, load hooks, etc.) must be deducted from the lift capacity values. The working load of the lifting device must be observed. In accordance with EU Standard EN 474-5 for object handling applications hose rupture valves on the boom and stick cylinders, an overload warning device and the lift capacity table in the cab are required. For object handling application the machine has to be supported on a level ground.

LIFTING CAPACITY MHL354

Height [m]	Undercarriage outrigger	Reach [m]					
		3.0	4.5	6	7.5	9	10.5
12	not supported		8.7° (8.7°) (8.7°)**				
10.5	not supported			8.6 (9.3°) (9.3°)**			
9	not supported			8.7 (10.8) (10.9°)**	6.1 (7.5) (8.3)**		
7.5	not supported			8.6 (10.7) (11.1°)**	6.1 (7.5) (8.2)**	4.5 (5.6) (6.2)**	
6	not supported		13.0 (14.8°) (14.8°)**	8.3 (10.4) (11.4)**	5.9 (7.3) (8.1)**	4.5 (5.5) (6.1)**	3.5 (4.3) (4.8)**
4.5	not supported		12.0 (15.7) (17.2°)**	7.9 (9.9) (10.9°)**	5.7 (7.1) (7.8)**	4.4 (5.4) (6.0)**	3.5 (4.3) (4.8)**
3	not supported		11.0 (13.2°) (13.2°)**	7.4 (9.4) (10.4°)**	5.4 (6.8) (7.6)**	4.2 (5.3) (5.9)**	3.4 (4.2) (4.7)**
1.5	not supported		6.2° (6.2°) (6.2°)**	7.0 (9.0) (10.0°)**	5.2 (6.6) (7.4)**	4.1 (5.1) (5.7)**	3.3 (4.2) (4.7)**
0	not supported		6.7° (6.7°) (6.7°)**	6.9 (8.8) (9.8°)**	5.1 (6.5) (7.2)**	4.0 (5.1) (5.7)**	
Max. reach 11.3 m							
2.53	not supported						3.1 (3.8) (4.3)**



MHL364

TECHNICAL DATA

SERVICE WEIGHT WITHOUT ATTACHMENT

MHL364 F	45–48.1 t
----------	-----------

DIESEL ENGINES

	EU Stage V / U.S. Tier 4	EU Stage IIIA / U.S. Tier 3 *
Manufacturer & model	Deutz TCD 7.8 L6 4V	Deutz TCD 2013 L06 2V
Type	6-cylinder inline	6-cylinder inline
Engine operation	4-stroke engine, direct common-rail fuel injection, turbocharger with charge air intercooling, controlled exhaust gas recirculation, diesel particle filter with a continuously regenerating system and SCR catalytic converter	4-stroke engine, direct common-rail fuel injection, turbocharger with charge air intercooling
Power	190 kW	186 kW
Nominal speed	2000 rpm	2000 min ⁻¹
Displacement	7.8 l	7.2 l
Cooling system	Water and charge air cooling with temperature controlled fan speed	Water and charge air cooling with temperature controlled fan speed
Exhaust emission standard	EU Stage V / U.S. Tier 4	EU Stage IIIA / U.S. Tier 3 *
Fuel tank	580 l diesel	580 l diesel
DEF tank	50 l Ad Blue	—

ELECTRICAL SYSTEM

Alternator	28 V / 100 A
Voltage	24 V
Batteries	2 × 12 V / 110 Ah / 750 A
Lights	2 × LED floodlights at the front of the machine, rear lights and indicator lights

HYDRAULIC SYSTEM

Cooling system	Separated high-performance cooler with temperature-dependent fan drive
Hydraulic oil filter	Flow-optimized return filters, integrated in the oil tank. Filter fineness defined at a beta value β(10) = 200 guarantees 99.5% separation of dirt particles with 10 µm. Very good separation values are already achieved with particle sizes of 3 µm. Generously dimensioned for long operating times.
Max. pump flow	2 × 280 l/min & 1 × 140 l/min (for slewing)
Max. pressure	320 / 360 bar
Hydraulic tank	520 l

TRAVEL DRIVE

Hydrostatic drive through infinitely variable axial piston motor with directly mounted travel brake valves, 4-wheel drive	
Travel speed	0–20 km/h
Turning radius	6.5 m

SLEWING GEAR

Slewing ring	Internally geared double row slewing ring bearing, greasing via automatic lubrication system
Drive	3-stage planetary gear with integrated multi-disc brake
Swing speed	0–6 rpm infinitely variable
Swing brake	Electrically operated

UNDERCARRIAGE

Front axle	Planetary drive axle with integrated drum brake, rigidly mounted, max. steering angle 27°
Rear axle	Planetary drive axle with integrated drum brake, self-aligning bearing with automatic oscillating lock
Stabilization	Support blade with integrated cylinder protection on side of oscillating axle
Tires	Pneumatic tires, 8-fold 14.00-24

BRAKES

Service brake	Hydraulic single-circuit braking system acting on all four wheel pairs
Parking brake	Electro-hydraulically actuated spring-loaded disk brake on the front axle, works on both axles

OPERATOR'S CAB

Cab	Reinforced steel structure, soundproofed, heat-insulated panoramic windows for best all-round visibility, front window with roller blind, glass panel in the cabin roof with sliding blind. Heating and air conditioning, separate heat exchangers, fresh and recirculated air filters. Multifunction touch display, bottle holder, paper clip and multiple storage and mounting options. Digital radio (DAB+, USB, Bluetooth and hands-free), USB charging station 5V.
Air-conditioning	Automatic air-conditioning. Infinitely variable heating with 8-speed fan, 10 adjustable air nozzles, 3 defroster nozzles.
Operator's seat	Air-cushioned comfort seat with swinging armrests / joysticks, safety belt, lumbar support and headrest. Enables fatigue-free work due to universal adjustment options for the seat position, seat inclination and the arrangement of the seat cushion in relation to the armrests and joysticks.
Monitoring	Ergonomically arranged, glare-free Multifunction display. Automatic monitoring and storage of deviating operating states (e.g. all hydraulic oil filters, hydraulic oil temperature – coolant and charge air temperature – diesel particulate filter loading, steering), visual and audible warning. Diagnostic option for the individual sensors via the multifunction display. Rear view and side view camera on the right with separate monitor

Noise level EU Stage V / U.S. Tier 4	Sound power level (ambience) LWA 101.8 dB(A) (metered) acc. to directive 2000/14/EC LWA 104 dB(A) (guaranteed) acc. to directive 2000/14/EC Sound pressure level (inside the cabin) acc. to directive ISO 6396 LpA 73 dB(A)
---	---

EU Stage IIIA / U.S. Tier 3*	LWA 101.5 dB(A) (metered) acc. to directive 2000/14/EC LWA 104 dB(A) (guaranteed) acc. to directive 2000/14/EC Sound pressure level (inside the cabin) acc. to directive ISO 6396 LpA 72 dB(A)
-------------------------------------	--

Vibrations	Weighted r.m.s. value of acceleration of upper limbs under 2.5 m/s ² (98 in/s ²) Weighted effective value of acceleration for the seat and feet under 0.5 m/s ² (20 in/s ²)
-------------------	--

Certification in accordance with CE guidelines

* for low-regulated markets

EQUIPMENT

ENGINE

	Standard	Option
Intercooler and coolant radiator	●	
Direct electronic fuel injection/common rail	●	
Advanced automatic idle incl. engine shut-off function	●	
Engine preheating		●
Engine diagnostics interface	●	
Temperature-dependent fan drive	●	
System-controlled fan drive with fan speed monitoring	●	

UNDERCARRIAGE

Support blade on side of oscillating axle; integrated cylinder protection	●	
All-wheel drive	●	
Rear axle oscillating lock	●	
Special paint		●
Drum brakes	●	
Toolbox, small	●	
Toolbox, large		●
Access	●	
Fenders		●
Additional support blade		●

UPPERCARRIAGE

Separated high-performance cooling system	●	
Hydraulic oil cooler with temperature-dependent fan drive	●	
Fan drive reversing function		●
Lockable maintenance hatches, with gas struts	●	
Automatic central lubrication system	●	
Rear view camera	●	
Side view camera	●	
Travel alarm		●
Electric refuelling pump		●
Lighting protection		●
Special paint (customer paint work)		●
Cyclone prefilter		●

CAB

	Standard	Option
Single-pane safety glass (ESG)	●	
Sliding window in cab door	●	
Glazed roof panel	●	
Cabin with penetration resistant glass front and top (classification P5A)		●
Cabin with bullet-proof glass (classification P8B)		●
Windshield washer system	●	
Washing device for roof window		●
Air-cushioned operator seat with headrest, seatbelt, and lumbar support	●	
Seat heating		●
Joystick steering	●	
Steering column, height and tilt adjustable		●
Automatic air conditioning system	●	
Independent heating system		●
Multi-function display	●	
Document clip	●	
Protective grilles to front and roof		●
12V transformer		●
Radio USB & Bluetooth	●	
12V socket	●	
Fire extinguisher, dry powder		●

EQUIPMENT

Close proximity range limiter for dipperstick	●	
Coolant and hydraulic oil level monitoring system	●	
Filter system for attachments		●
Hose rupture valve for boom cylinder	●	
Hose rupture valve for stick cylinder	●	
Overload warning device		●
Quick coupling on dipperstick	●	
Dipperstick impact protection		●
Active cyclone prefilter (TOP AIR)		●
Hydraulic oil preheating 230 V		●
Float switch for barge unloading		●
Lubrication of the grab suspension by central lubrication system	●	
LED front headlights	●	
Light packages LED		●
Fuchs Connect telematics system, incl. 5 years contract	●	

Further optional equipment available on request!



DIMENSIONS MHL364

All dimensions in mm

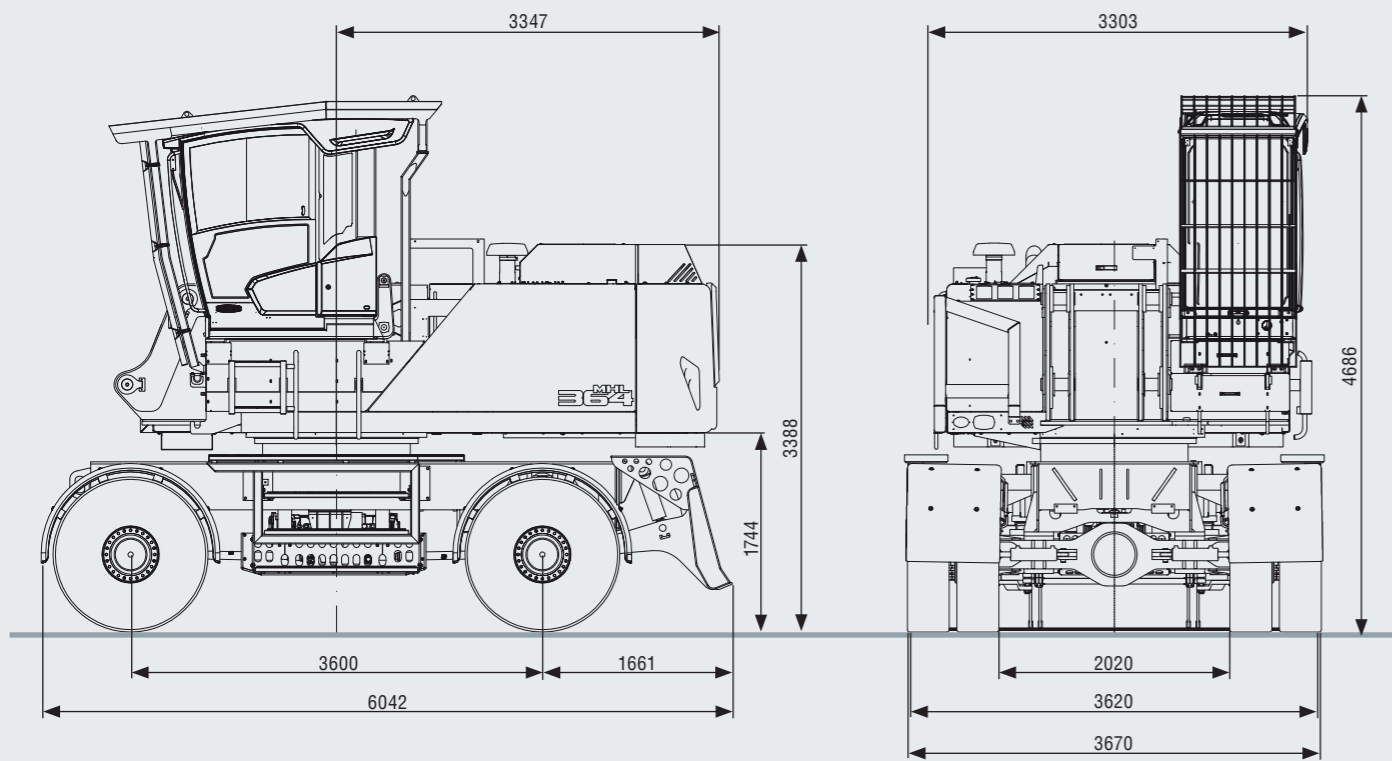

TRANSPORT DIMENSIONS MHL364

All dimensions in mm

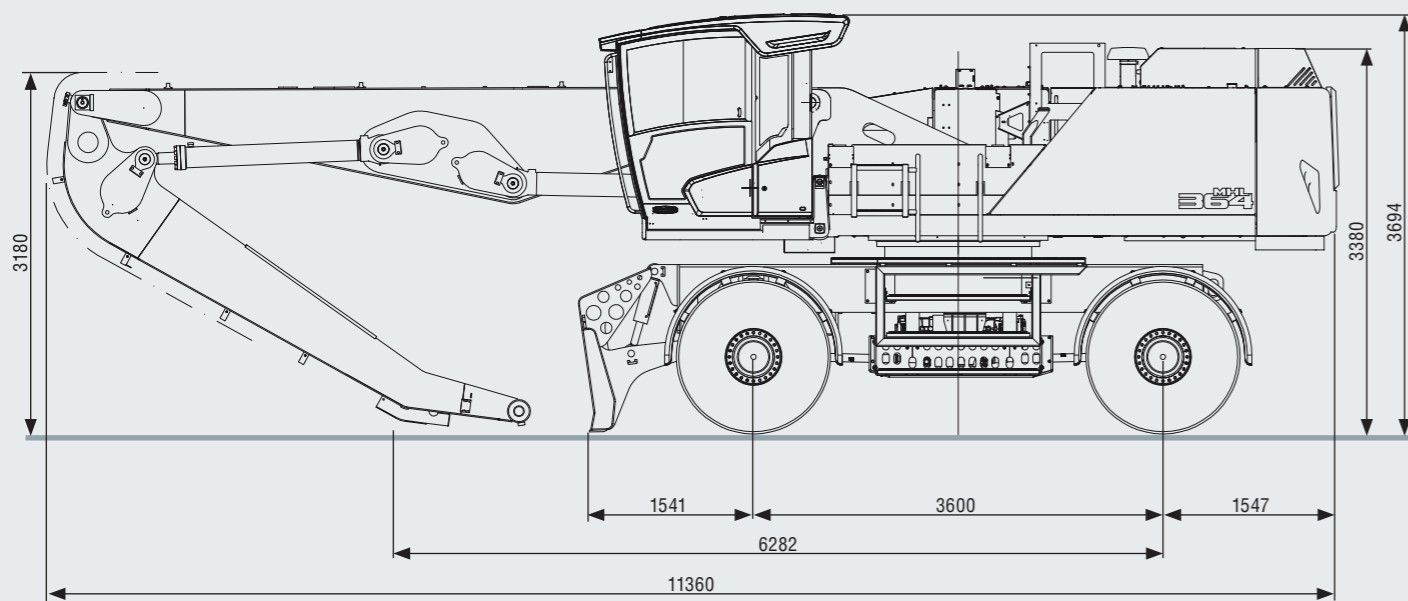

WORKING RANGE MHL364

REACH 12.1 M WITH DIPPER STICK

Loading equipment	Boom 6.4 m Dipper stick 4.7 m Multi-tine grapple
--------------------------	--

RECOMMENDED ATTACHMENTS

Grab size	2.0–3.2 m ² Depending on mission requirements
------------------	---

The lift capacity values are stated in metric tons (t). The pump pressure is 360 bar. In accordance with ISO 10567 the lift capacity values represents 75% of the static tipping loads or 87% of the hydraulic lifting force (marked *). On solid and level ground the values apply to a swing range of 360°. The (...) values apply in the longitudinal direction of the undercarriage. The values for "not supported" only apply via the steering axle or the locked oscillating axle. The weights of the attached load hoisting equipment (grab, load hooks, etc.) must be deducted from the lift capacity values. The working load of the lifting device must be observed. In accordance with EU Standard EN 474-5 for object handling applications hose rupture valves on the boom and stick cylinders, an overload warning device and the lift capacity table in the cab are required. For object handling application the machine has to be supported on a level ground.

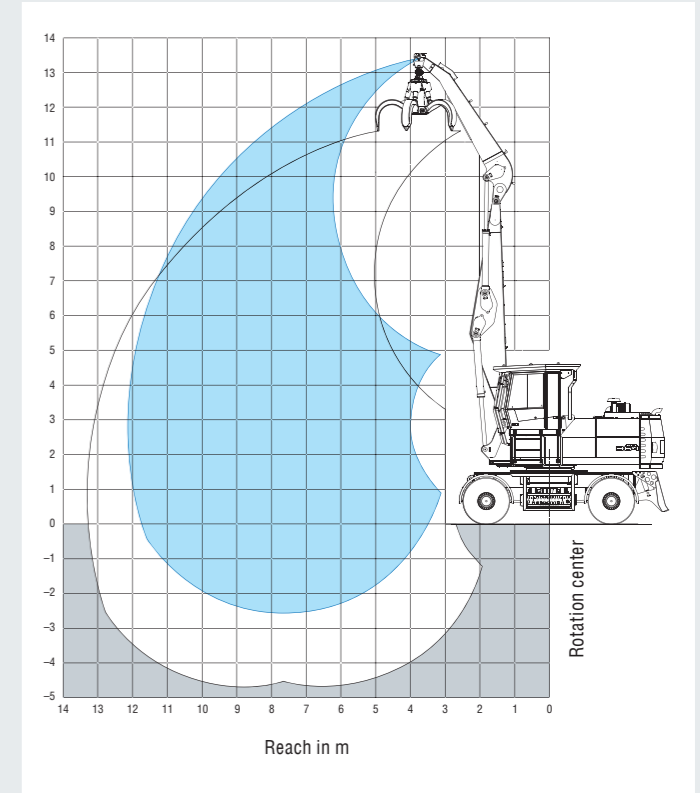

LIFTING CAPACITY MHL364

Height [m]	Undercarriage outrigger	Reach [m]					
		4,5	6	7,5	9	10,5	12
12	not supported		13,1° (13,1°) (13,1°)**				
10,5	not supported			11,2 (13,1°) (13,1°)**			
9	not supported			11,2 (13,0°) (13,0°)**	8,5 (10,3) (11,3)**		
7,5	not supported		15,4 (15,4°) (15,4°)**	11,1 (13,2°) (13,2°)**	8,4 (10,3) (11,2)**	6,7 (8,1) (8,9)**	
6	not supported		15,1 (16,8°) (16,8°)**	10,8 (13,3) (13,9)**	8,3 (10,1) (11,1)**	6,6 (8,0) (8,8)**	
4,5	not supported	22,1 (26,3) (26,3)**	14,4 (18,1) (18,8)**	10,5 (12,9) (14,1)**	8,1 (9,9) (10,8)**	6,5 (7,9) (8,7)**	
3	not supported	20,3 (22,8) (22,8°)**	13,6 (17,2) (18,9°)**	10,0 (12,5) (13,7°)**	7,8 (9,7) (10,6)**	6,4 (7,8) (8,6)**	5,3 (6,5) (7,1)**
1,5	not supported	10,8 (10,8) (10,8)**	13,0 (16,6°) (18,2°)**	9,7 (12,1) (13,3°)**	7,6 (9,4) (10,4)**	6,3 (7,7) (8,5)**	5,3 (6,4) (7,0)**
0	not supported	11,4 (11,4) (11,4)**	12,7 (16,3) (17,9°)**	9,5 (11,9) (13,1°)**	7,5 (9,3) (10,3)**	6,2 (7,6) (8,4)**	
-1,5	not supported		12,7 (16,0°) (16,0°)**	9,4 (11,8) (12,6°)**	7,5 (9,3) (9,8)**	6,2 (6,9) (6,9)**	
Max. reach 12,12 m							
2,9	not supported						5,2 (6,4) (6,4)**

MODULAR SYSTEM

Attachments

Timber grab



Work equipment

Work equipment straight

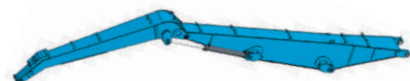

Uppercarriage

Rigid cab system

Viewing height: max. 4 m

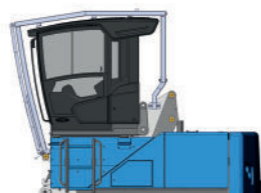

Undercarriage

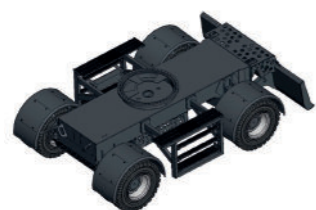

Mobile: Standard-undercarriage

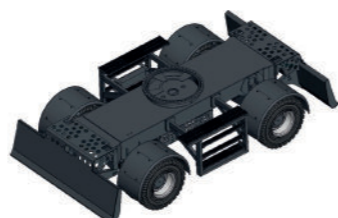

Mobile: 2 support blades

Timberpackage



Site protection guard

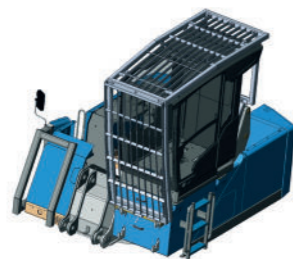

Cab protection guard



Lifting cylinder guard

Furthermore:
Side camera
Actimo XXL seat
Additional lights

NOTES

Lined area for notes.





GET A HANDLE ON FLEET MANAGEMENT.

Fuchs Telematics System: Recognize and Optimize Potential.

The Fuchs Telematics system: know exactly how and where everything is running.

The system offers a modern solution to help you analyze and optimize the efficiency of your machines. It records and communicates valuable information on the operating status of each individual machine. Where are the machines? How are they working? Is a service check pending? Take advantage of this advanced software and get a handle on your fleet management with the tool that connects for you.

ALL-IN-ONE MACHINE MANAGEMENT. EVERYTHING AT A GLANCE: OPERATING DATA, MACHINE STATUS, GPS DATA

Record, display, and analyse data: high efficiency through precise information

- Available online anywhere and at any time*: comprehensive information on the GPS location, start and stop times, fuel consumption, operating hours, maintenance status, and much more.
- User-friendly interface: displays information clearly for at a glance metrics and diagnostics. Take action before damage occurs: predetermined maintenance intervals are signaled and error messages are displayed in plain text messages.
- The Fuchs Telematics system is optionally available or can be retrofitted into existing machines to help control your operating costs and keep your machines in top shape.

* Internet connection required

