

CRUSHING

SCREENING

WASHING

CONVEYING

COMPONENTS

PLANTS

CONSTRUCTION

AFTERMARKET

WASHING EQUIPMENT PRODUCT HANDBOOK



TABLE OF CONTENTS



SCRUBBING

Coarse Material Washer	37
» Mildly scrubs while removing unwanted material.	
Blade Mill Washer	41
» Dry feed converted to slurry for screening efficiency.	
Log Washer	45
» Aggressively scrubs toughest clays from rocks.	
Attrition Mill	49
» Surface polishing while breaking up of bonded clusters.	

CLASSIFYING

Classifying Tank	3
» Remove water and classifies feed.	
Density Sizer	11
» Separates material for precise classification.	
Helix® Cyclone	25
» Removes unwanted contaminants and recovers fines.	
Spirit® Sand Plant	29
» Sump, pump, cyclone and dewatering screen package.	

WASHING

Aggredry® Washer	13
» Dewater material and removes silt.	
Alliance® Low Water Washer	17
» Accepts dry feed in crushing circuit, washes and dewater fines.	
Fine Material Washer	21
» Dewater material and removes silt.	
Spirit® Sand Plant	29
» Sump, pump, cyclone and dewatering screen package.	

DEWATERING

Aggredry® Washer	13
» Dewater in addition to removing silt.	
Alliance® Low Water Washer	17
» Accepts dry feed in crushing circuit, washes and dewater fines.	
Fine Material Washer	21
» Dewater in addition to removing silt.	
Dewatering Screen	33
» High frequency screen reduces moisture.	

OTHER

Pugmill Mixer	53
» Mix aggregate for production of road base.	
Concrete Washout System	55
» Recover sand from ready-mix trucks.	



CLASSIFYING TANK

Remove excess water and classifies feed into multiple spec products.

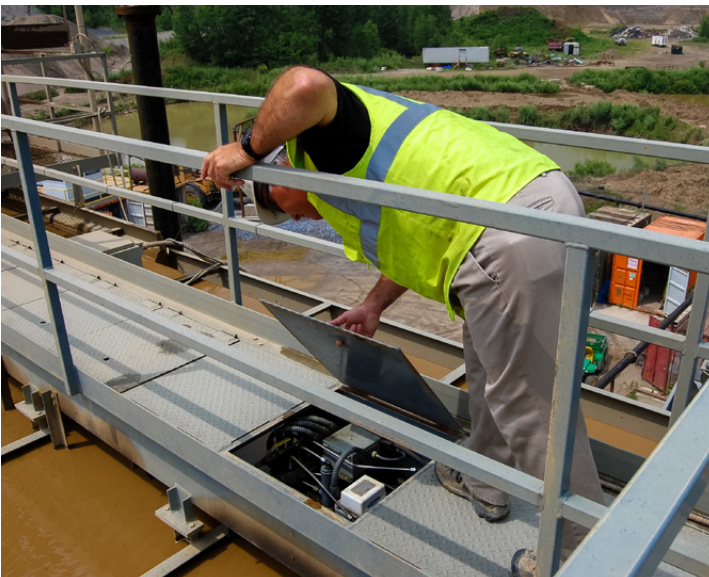

APPLICATIONS

- » Convert variable feed to in-spec products
- » Produce three uniform products from single feed
- » Make (2) spec and (1) excess product
- » Scalp excess water from dredge feed
- » Downstream dewatering efficiency
- » Stationary, skid-mounted or portable
- » 6-11 stations per tank

FEATURES

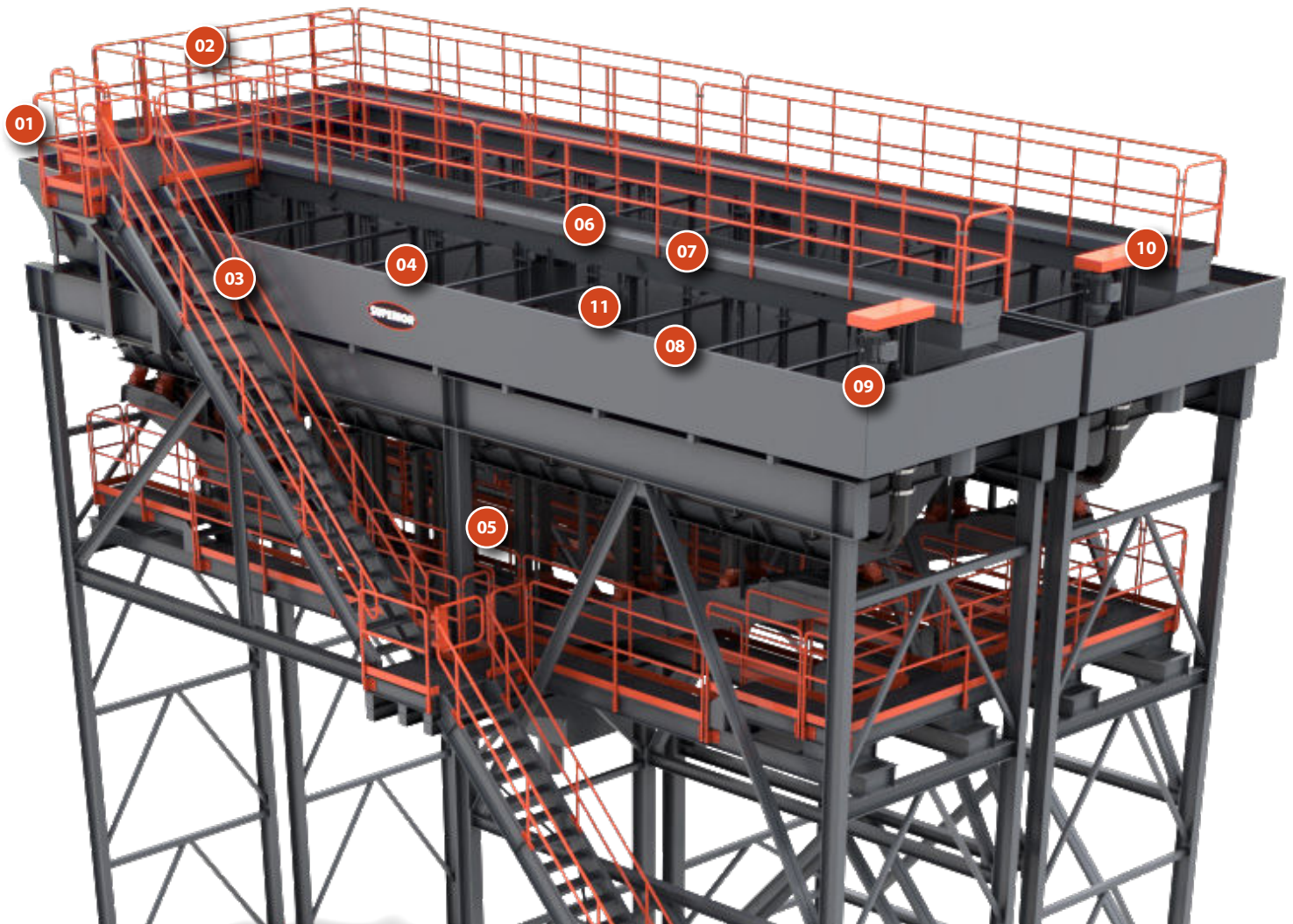

01/ AR LINED FEEDBOX

Standard abrasion resistant steel lining shields feedbox and trough from wear.

02/ SLOPED FEEDBOX

Slanted design promotes better flow of material to tank.

03/ STAIRS/WALKWAY

Compared to ladders, stairs and walkways offer simple, safe access to tank components.

04/ HIGH CAPACITY TANK

1/4" sides and end plates with 1/2" bottom.

05/ AR LINED BLENDING FLUME

Collects material.

06/ FULL-LENGTH VALVE BRIDGE

Raised at least 4" (101mm) more than competitors to prevent water from damaging mechanical parts.

07/ HINGED WALKWAY PLATES

Easily swing open to access mechanical valve stations below walkway.

08/ ADJUSTABLE WEIR

Adjust up or down to maximize fines retention.

09/ OVERFLOW

Wraps around three sides.

10/ RECIRCULATING PUMP

Pump to minimize water usage by recycling the classifying tank overflow to the rising current cells.

11/ RISING CURRENT CELLS

Improves separation efficiency by keeping the lighter material in suspension while letting heavier particles settle.

HIGHLIGHTS

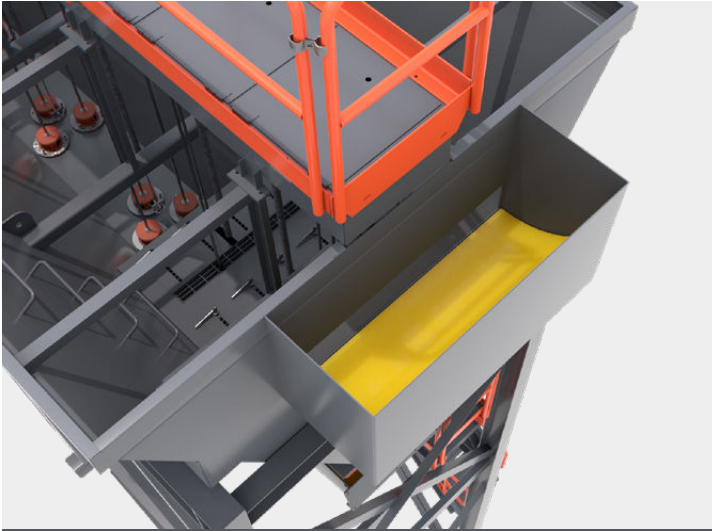

01/ AR LINED FEEDBOX



04/ HIGH CAPACITY TANK



06/ FULL-LENGTH VALVE BRIDGE



07/ HINGED WALKWAY PLATES



09/ OVERFLOW



10/ RECIRCULATING PUMP

MODELS

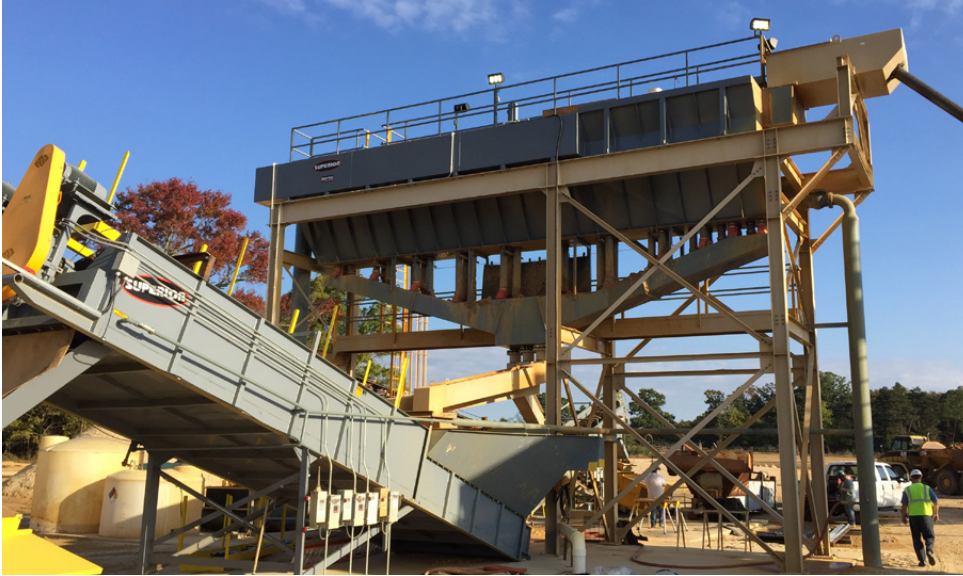

STATIONARY

- » Single or double tanks
- » 6-22 stations
- » Valve bridge walkway with railings
- » AR lined blending flumes and feedboxes
- » Urethane valves, seats and discharge elbows
- » Self-Aligning valves and seats
- » Onsite spec testing and control system training



SEMI-PORTABLE

- » Skid-mounted, modular design
- » 7-11 stations
- » Aggredry® Washer or Fines Material Washer
- » Produce (2) individual products or
- » Produce maximum primary product
- » Prewired plant



PORTABLE

- » Fifth wheel hitch
- » 7-11 stations
- » Aggredry® Washer or Fines Material Washer
- » Air brakes
- » Lights
- » Hydraulic leveling jacks
- » Prewired plant

* Larger than 8' x 32' tanks have to be disassembled prior to transport.

AGGRESPEC[®] CONTROL SYSTEMS



AGGRESPEC[®] III CONTROL SYSTEM

- » Microsoft Windows-based control system is familiar and easy to use
- » Up to 15% more productivity than single method programs
- » Automatically create and maintain tight specifications
- » Control from remote location (i.e. home or office)
- » Store and recall unlimited number of mixes
- » Program automatic tank cleanout
- » Patented twin tank control operates up to 22 stations
- » Retrofit to competitor tanks
- » Excellent for dredge and natural sand feeds

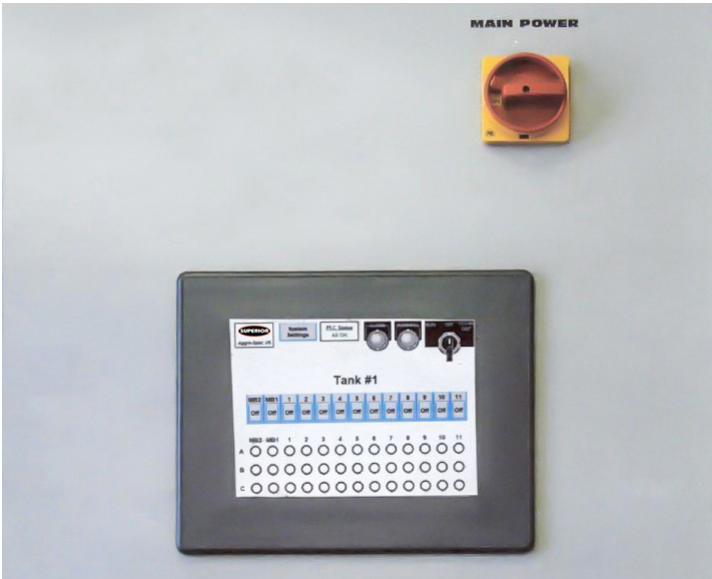

AGGRESPEC[®] I CONTROL SYSTEM

- » Operate from simplified PLC panel
- » Touch screen
- » Manual calculations directs product in tank
- » Monitor and adjust essential parameters
- » Excellent for quarry applications

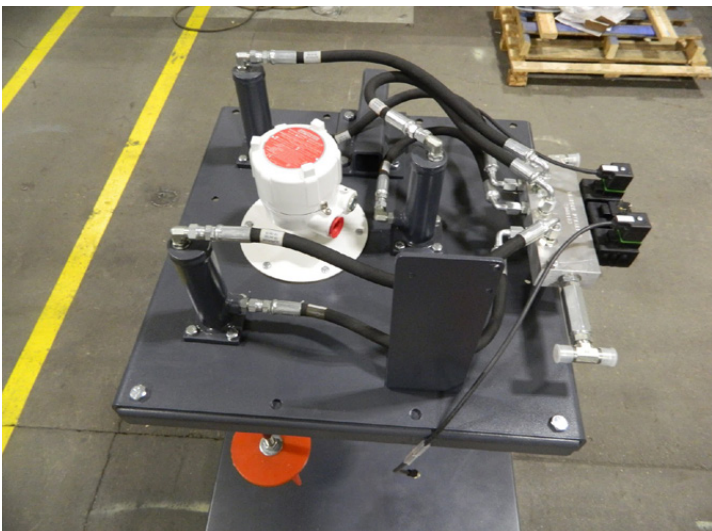

VALVE STATION

- » Just below the valve bridge
- » High pressure hydraulic hoses
- » Encourages faster valve opening/closing
- » Achieve more precise spec

HOW IT WORKS

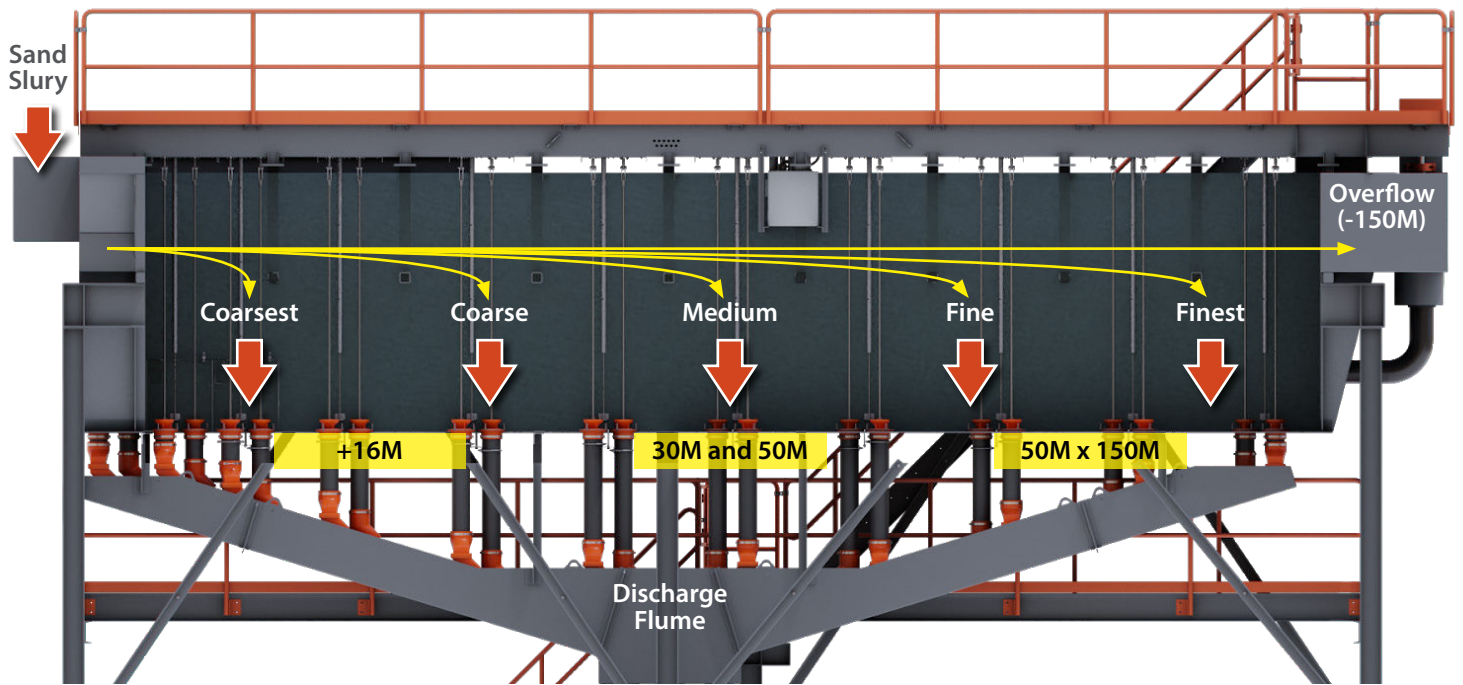

» Sand enters tank and flows along its length. Particles drop out as the velocity of the water slows and allows them to drop.

STATIONARY CLASSIFIER SPECIFICATIONS

Tank Size ft (m)	Stations	Estimated Tank Weight lbs. (kg)	Estimated Support Structure Weight** lbs. (kg)	Water Capacity GPM (m ³ /hr)		
				100 Mesh (150 µm)	150 Mesh (113 µm)	200 Mesh (75 µm)
Single Tank						
8' x 28' (2 x 9)	8	16,000 (7,258)	13,000 (5,897)	3,200 (726)	1,600 (363)	N/A
8' x 32' (2 x 10)	9	18,000 (8,165)	14,180 (6,432)	3,500 (794)	1,800 (408)	N/A
10' x 24' (3 x 7)	7	18,000 (8,165)	13,800 (6,260)	3,500 (794)	1,800 (408)	N/A
10' x 28' (3 x 9)	8	20,000 (9,072)	14,000 (6,350)	4,100 (931)	2,100 (477)	N/A
10' x 32' (3 x 10)	9	24,000 (10,886)	15,200 (6,895)	4,700 (1,067)	2,400 (545)	1,250 (283)
10' x 36' (3 x 11)	10	28,000 (12,701)	16,500 (7,484)	5,300 (1,204)	2,700 (613)	1,400 (318)
10' x 40' (3 x 12)	11	30,000 (13,608)	18,000 (8,165)	5,900 (1,340)	3,000 (681)	1,500 (340)
12' x 48' (4 x 15)	11	44,000 (19,958)	23,600 (10,705)	8,100 (1,840)	4,200 (953)	2,150 (488)
Double Tank						
10' x 32' (3 x 10)	9	48,900 (22,181)	30,300 (13,744)	9,400 (2,135)	4,800 (1,090)	2,500 (567)
10' x 36' (3 x 11)	10	53,000 (24,040)	32,700 (14,833)	10,600 (2,408)	5,400 (1,226)	2,800 (635)
10' x 40' (3 x 12)	11	56,000 (25,401)	35,200 (15,967)	11,800 (2,680)	6,000 (1,363)	3,000 (681)
12' x 48' (4 x 15)	11	86,000 (39,009)	48,200 (21,863)	16,200 (3,679)	8,400 (1,908)	4,300 (976)

**One chute, one walkway and one stairs

SEMI-PORTABLE CLASSIFIER SPECIFICATIONS

Tank Size ft (m)	Stations	Estimated Weight lbs. (kg)	Screw Size in x ft (mm x m)	Capacity TPH (MTPH)	Water Capacity GPM (m ³ /hr)		
					100 Mesh (150 μm)	150 Mesh (113 μm)	200 Mesh (75 μm)
Semi-Portable Classifier with Fine Material Washer - Triple Flume							
8' x 28' (2 x 9)	8	42,000 (19,050)	Twin 36" x 25' (914 x 7)	200 (181)	3,200 (726)	1,600 (363)	N/A
8' x 32' (2 x 10)	9	48,500 (21,999)	Twin 36" x 25' (914 x 7)	200 (181)	3,500 (794)	1,800 (408)	N/A
10' x 24' (3 x 7)	7	50,000 (22,679)	Twin 36" x 25' (914 x 7)	200 (181)	3,500 (794)	1,800 (408)	N/A
10' x 28' (3 x 9)	8	51,000 (23,133)	Twin 36" x 25' (914 x 7)	200 (181)	4,100 (931)	2,100 (477)	N/A
10' x 32' (3 x 10)	9	51,500 (23,360)	Twin 36" x 25' (914 x 7)	200 (181)	4,700 (1,067)	2,400 (545)	1,250 (283)
10' x 36' (3 x 11)	10	58,500 (26,535)	Twin 36" x 25' (914 x 7)	200 (181)	5,300 (1,204)	2,700 (613)	1,400 (318)
10' x 40' (3 x 12)	11	63,000 (28,576)	Twin 36" x 25' (914 x 7)	200 (181)	5,900 (1,340)	3,000 (681)	1,500 (340)
8' x 32' (2 x 10)	9	60,000 (27,216)	Twin 44" x 32' (1,118 x 10)	350 (318)	3,500 (794)	1,800 (408)	950 (215)
10' x 32' (3 x 10)	9	64,500 (29,257)	Twin 44" x 32' (1,118 x 10)	350 (318)	4,700 (1,067)	2,400 (545)	1,250 (283)
10' x 36' (3 x 11)	10	67,000 (30,391)	Twin 44" x 32' (1,118 x 10)	350 (318)	5,300 (1,204)	2,700 (613)	1,400 (318)
10' x 40' (3 x 12)	11	68,000 (30,844)	Twin 44" x 32' (1,118 x 10)	350 (318)	5,900 (1,340)	3,000 (681)	1,500 (340)
10' x 40' (3 x 12)	11	97,000 (43,999)	Twin 54" x 35' (1,372 x 11)	550 (500)	5,900 (1,340)	3,000 (681)	1,500 (340)
10' x 40' (3 x 12)	11	132,000 (59,874)	Twin 66" x 35' (1,676 x 11)	800 (725)	5,900 (1,340)	3,000 (681)	1,500 (340)
12' x 48' (4 x 15)	11	91,000 (41,277)	Twin 44" x 32' (1,118 x 10)	350 (318)	8,100 (1,840)	4,200 (953)	2,150 (488)
12' x 48' (4 x 15)	11	116,000 (52,617)	Twin 54" x 35' (1,372 x 11)	550 (500)	8,100 (1,840)	4,200 (953)	2,150 (488)
12' x 48' (4 x 15)	11	150,000 (68,039)	Twin 66" x 35' (1,676 x 11)	800 (725)	8,100 (1,840)	4,200 (953)	2,150 (488)
12' x 48' (4 x 15)	11	175,000 (79,379)	Twin 72" x 35' (1,829 x 11)	950 (861)	8,100 (1,840)	4,200 (953)	2,150 (488)

Semi-Portable Classifier with Aggredry® Dewatering Washer							
8' x 28' (2 x 9)	8	56,000 (25,401)	Twin 36" (914)	200 (181)	3,200 (726)	1,600 (363)	N/A
8' x 32' (2 x 10)	9	62,500 (28,350)	Twin 36" (914)	200 (181)	3,500 (794)	1,800 (408)	N/A
10' x 28' (3 x 9)	7	64,000 (29,030)	Twin 36" (914)	200 (181)	4,100 (931)	2,100 (477)	N/A
10' x 32' (3 x 10)	8	65,000 (29,483)	Twin 36" (914)	200 (181)	4,200 (953)	2,400 (545)	1,250 (283)
10' x 36' (3 x 11)	9	65,500 (29,710)	Twin 36" (914)	200 (181)	5,300 (1,204)	2,700 (613)	1,400 (318)
10' x 40' (3 x 12)	10	72,500 (32,885)	Twin 36" (914)	200 (181)	5,900 (1,340)	3,000 (681)	1,500 (340)
8' x 32' (2 x 10)	9	78,000 (35,380)	Twin 48" (1,219)	400 (363)	5,300 (1,204)	1,800 (408)	950 (215)
10' x 32' (3 x 10)	9	82,500 (37,421)	Twin 48" (1,219)	400 (363)	4,700 (1,067)	2,400 (545)	1,250 (283)
10' x 36' (3 x 11)	10	85,000 (38,555)	Twin 48" (1,219)	400 (363)	5,300 (1,204)	2,700 (613)	1,400 (318)
10' x 40' (3 x 12)	11	86,000 (39,009)	Twin 48" (1,219)	400 (363)	5,900 (1,340)	3,000 (681)	1,500 (340)
10' x 40' (3 x 12)	11	140,000 (63,503)	Twin 66" (1,676)	800 (725)	5,900 (1,340)	3,000 (681)	1,500 (340)
12' x 48' (4 x 15)	11	109,000 (49,442)	Twin 48" (1,219)	400 (363)	8,100 (1,840)	4,200 (953)	2,150 (488)
12' x 48' (4 x 15)	11	158,000 (71,668)	Twin 60" (1,524)	600 (544)	8,100 (1,840)	4,200 (953)	2,150 (488)

FULLY-PORTABLE CLASSIFIER SPECIFICATIONS

Tank Size ft (m)	Stations	Estimated Weight lbs. (kg)	Screw Size in x ft (mm x m)	Capacity TPH (MTPH)	Axle/Tires	Water Capacity GPM (m ³ /hr)		
						100 Mesh (150 µm)	150 Mesh (113 µm)	200 Mesh (75 µm)
Fully Portable Classifier with Fine Material Washer - Triple Flume								
8' x 28' (2 x 9)	8	51,000 (23,133)	Twin 36" (914)*	200 (181)	2/8 or 3/12	3,200 (0.20)	1,600 (0.10)	N/A
8' x 32' (2 x 10)	9	52,000 (23,587)	Twin 36" (914)*	200 (181)	2/8 or 3/12	3,500 (0.22)	1,800 (0.11)	950 (0.05)
8' x 32' (2 x 10)	9	73,500 (33,339)	Twin 44" (1,118)*	350 (318)	3/12	3,500 (0.22)	1,800 (0.11)	950 (0.05)
10' x 28' (3 x 9)	8	81,000 (36,741)	Twin 44" x 32' (1,118 x 10)	350 (318)	3/12	4,100 (0.25)	2,100 (0.13)	N/A
10' x 32' (3 x 10)	9	86,000 (39,009)	Twin 44" x 32' (1,118 x 10)	350 (318)	3/12	4,700 (0.29)	2,400 (0.15)	1,250 (0.07)
10' x 36' (3 x 11)	10	88,000 (39,916)	Twin 44" x 32' (1,118 x 10)	350 (318)	3/12	5,300 (0.33)	2,700 (0.17)	1,400 (0.08)
10' x 40' (3 x 12)	11	95,000 (43,091)	Twin 44" x 32' (1,118 x 10)	350 (318)	3/12	5,900 (0.37)	3,000 (0.18)	1,500 (0.09)

*Screw length dependant of number of axles required therefore will be 25-ft or 28-ft.



DENSITY SIZER

Separates material for extremely precise classification of products.



APPLICATIONS

- » Extremely sharp classification
- » Cut range between 30-100 mesh
- » Separates by size or specific gravity
- » Lightweight material discharges over weir
- » Heavier, coarser sand exits bottom
- » -4 mesh maximum feed size
- » Split point easily adjusted

FEATURES

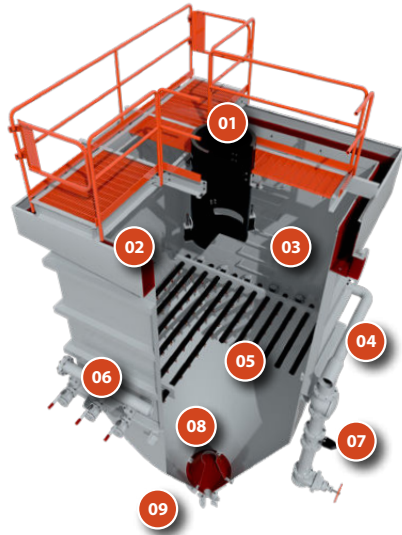

- 01/ FEED WELL**
Radially distributes material
- 02/ MAGNETIC URETHANE LINING IN WEIR**
- 03/ INTEGRATED LADDER FOR TANK ACCESS**
- 04/ U-SHAPED WATER MANIFOLD**
Ensures equal pressure water distribution
- 05/ SPRAY BARS**
Spray bar with nozzles to establish rising current
- 06/ FLUSH VALVES**
Maintenance spray bars without the need of entering the tanks
- 07/ GATE VALVE AND FLOW METER**
Monitor and control water flow
- 08/ URETHANE LINED DISCHARGE CONE**
Bolt-on replaceable lined cone
- 09/ PATENTED CONICAL LOWER CONE DESIGN**
Provides an even discharge flow of material and prevents buildup

HOW IT WORKS

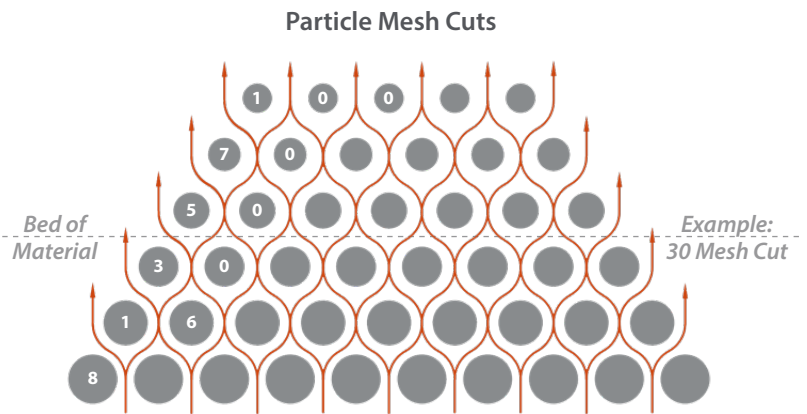
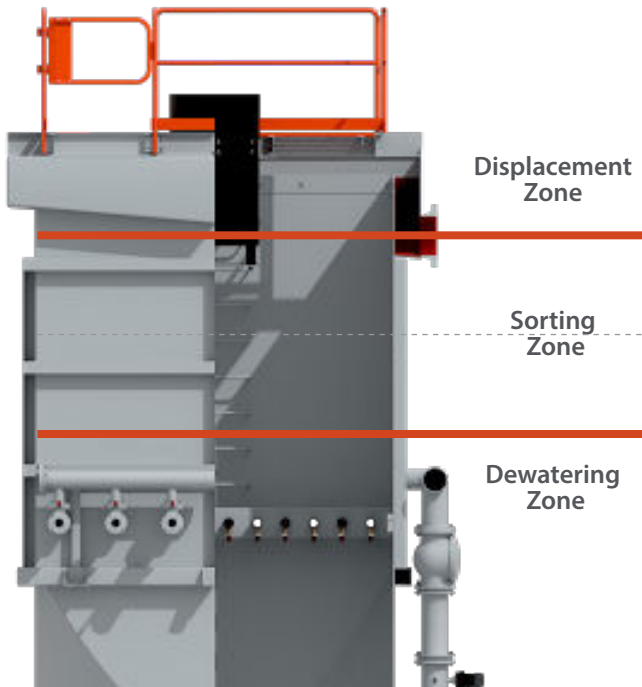

As particles are distributed throughout the sorting zone, depending on their density and size, the heavier particles settle through the dense medium. The lighter particles are hydraulically transported to the overflow.

OPERATING DIMENSIONS

	Size	Settling Area	Feed Capacity		Water Required	
	m (ft)	m ² (ft ²)	MTPH	STPH	m ³ /hr	GPM
DS4x4	1.2 x 1.2 (4 x 4)	1.5 (16)	14 - 60	15 - 65	23 - 57	100 - 250
DS6x6	1.8 x 1.8 (6 x 6)	3.5 (36)	32 - 132	35 - 145	51 - 128	225 - 565
DS7x7	2.1 x 2.1 (7 x 7)	4.6 (49)	41 - 177	45 - 195	68 - 174	300 - 765
DS8.5x8.5	2.6 x 2.6 (8.5 x 8.5)	6.8 (73)	62 - 272	68 - 300	102 - 261	142 - 355
DS10x10	3.1 x 3.1 (10 x 10)	9.3 (100)	84 - 363	93 - 400	142 - 355	625 - 1,560

The Superior Density Sizer can accept feed with a top size of 5mm and offers tight control over particle separation between 149-595µm. Feed rates and water requirements are dependent on gradation of material. Finer particles requires more time to settle and lower feed rates are required.



AGGREDRY® DEWATERING WASHER

Typically dewater material to as low as 8% moisture in addition to removing silt.



AS LOW AS 8% MOISTURE CONTENT

APPLICATIONS

- » Use in fine material applications
- » Self-contained fine material washer
- » Integrated dewatering screen
- » Low horsepower requirements
- » Remove unwanted, lightweight silts



FEATURES

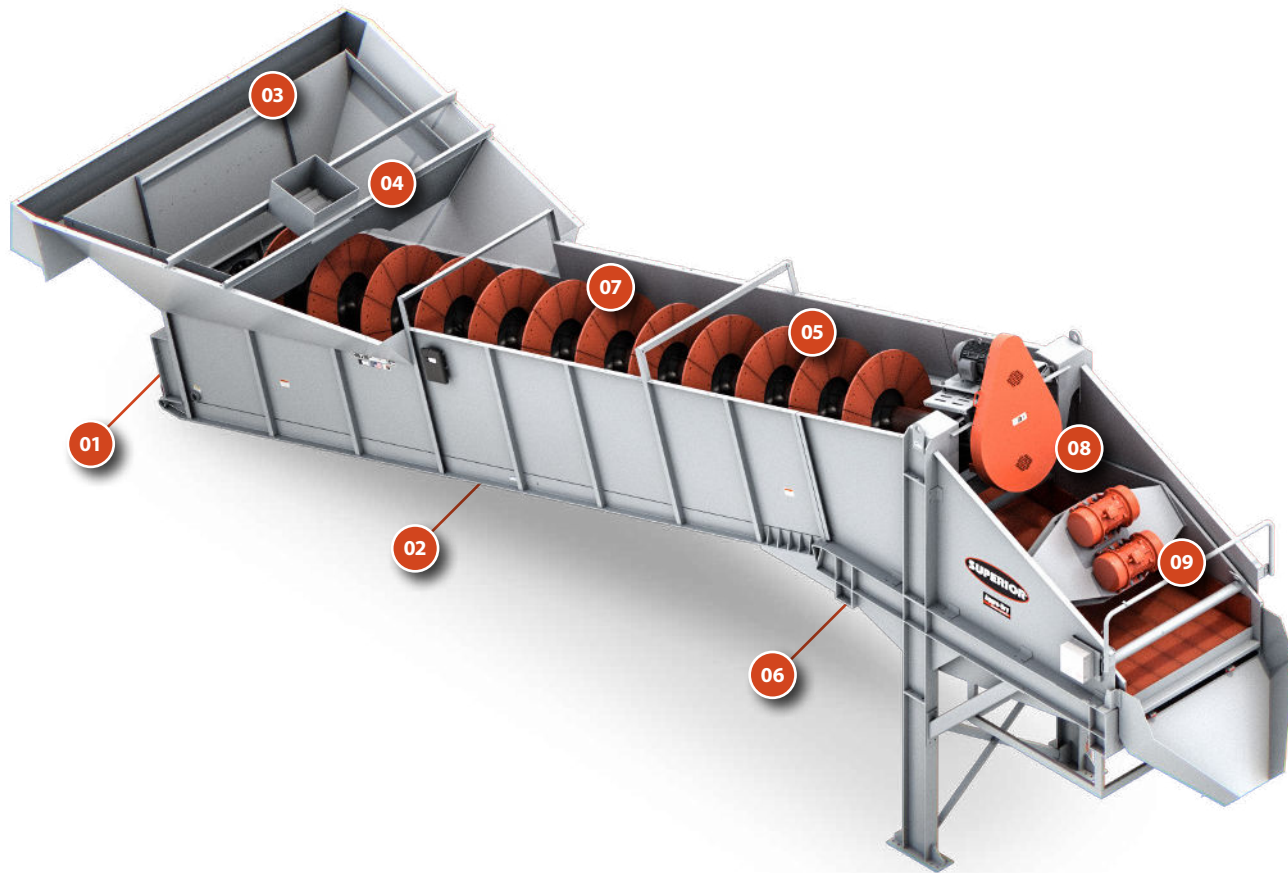

01/ SAFEGUARD OUTBOARD BEARING

Off-the-shelf pillow block bearing installed outside tank for protection and easy maintenance. (Not shown)

02/ CURVED BELLY PAN

Eliminates dead spots for material to gather common to 90° angles.

03/ ADJUSTABLE WEIR PLATE

Encourages overflow water to level, which maximizes fines retention.

04/ LOAD ZONE Baffle

Calms water to help maximize fines retention.

05/ WEAR SHOES

Standard rubber or optional urethane or abrasion resistant steel wear shoes. Manufactured with internal steel plate to hold up in harsh applications.

06/ PATENTED FINES RECOVERY JET

Recovers up to 3% of salable material.

07/ FINE MATERIAL SCREW

Accepts feed up to 3/4" (19mm) while removing unwanted fines in sand.

08/ INTEGRATED DEWATERING SCREEN

Unique sidewall media encourages water to drain from top and sides, which produces drier product.

09/ SCREEN SIDEWALLS

A deeper bed depth and urethane sidewalls remove more water for output as low as 8% moisture.

OPTIONS

TWIN SCREW

A-532 WEAR SHOES

FOLDING WING WALLS

ROAD PORTABLE PACKAGE

MATERIAL DISCHARGE CHUTE

BOOSTER PUMP

REDUCED SCREW SPEED

SAFETY COVERS

ROCK GRADE RUBBER WEAR SHOES

SKID FRAME

HIGHLIGHTS

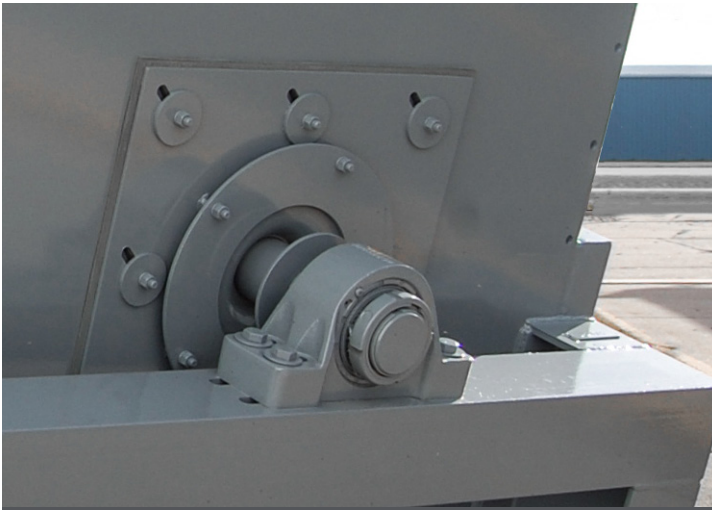

SAFEGUARD OUTBOARD BEARING

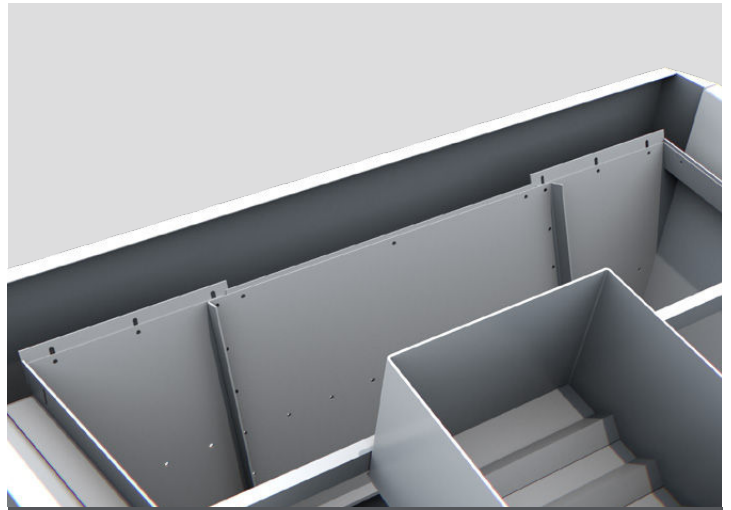

03/ ADJUSTABLE WEIR PLATE



06/ PATENTED FINES RECOVERY JET

- » Profit earned for quicker payback
- » Integrate into existing equipment
- » Low water requirements (90-100 gpm)
- » Low horsepower allows slurry pump to get fines back into the screw
- » Alternative to expensive sump and pump solutions
- » Fresh water booster pump option available to achieve require pressure



09/ SCREEN SIDE WALLS

PORTABLE AGGREDRY[®] WASH PLANT





Rock Face to Load Out[®]



AGGREDRY[®] DEWATERING WASHER

SPECIFICATIONS

	Screw Diameter inch (mm)	Capacity STPH (MTPH)	Screw Speed RPM	Max Material Size inch (mm)	Motor HP (kW)
SINGLE SCREW					
	24 (610)	50 (46)	32	3/8 (10)	7.5 (5.6)
	36 (915)	100 (91)	20	3/8 (10)	15 (11.2)
	48 (1,220)	200 (182)	16	3/8 (10)	25 (18.7)
	60 (1,524)	300 (273)	13	3/8 (10)	40 (29.9)

	Screw Diameter inch (mm)	Capacity STPH (MTPH)	Screw Speed RPM	Max Material Size inch (mm)	Motor HP (kW)
TWIN SCREW					
	two 48 (1,220)	400 (364)	17	3/8 (10)	two 25 (18.7)
	two 60 (1,524)	600 (545)	15	3/8 (10)	two 40 (29.9)
	two 66 (1,680)	800 (728)	14	3/8 (10)	two 50 (37.3)

FINES RECOVERY PROFIT CALCULATOR



SUPERIOR'S PATENTED FINES RECOVERY JET

Input values matching your plants specific data to calculate additional annual profit from fines recovery.

<input type="text"/>	X	<input type="text" value="3%"/>	=	<input type="text"/>	X	<input type="text"/>	X	<input type="text"/>	=	<input type="text"/>
Tons Per Day of Wet Sand Production		Saved From Waste Pond		Additional Saleable Tons		Cost Per Ton		Production Days in a Year		Additional Annual Profit



ALLIANCE® LOW WATER WASHER

Low water washer accepts dry feed in crushing circuit. Washes and dewateres fines.



AS LOW AS 8% MOISTURE CONTENT

APPLICATIONS

- » Produce valuable manufactured sand
- » Earn money from crusher dust
- » Accepts dry feed in crushing circuit
- » Greatly reduced water requirement
- » No haulage to separate wash site
- » Avoid multiple material handlings



Rock Face to Load Out®

 Patented Technology

FEATURES

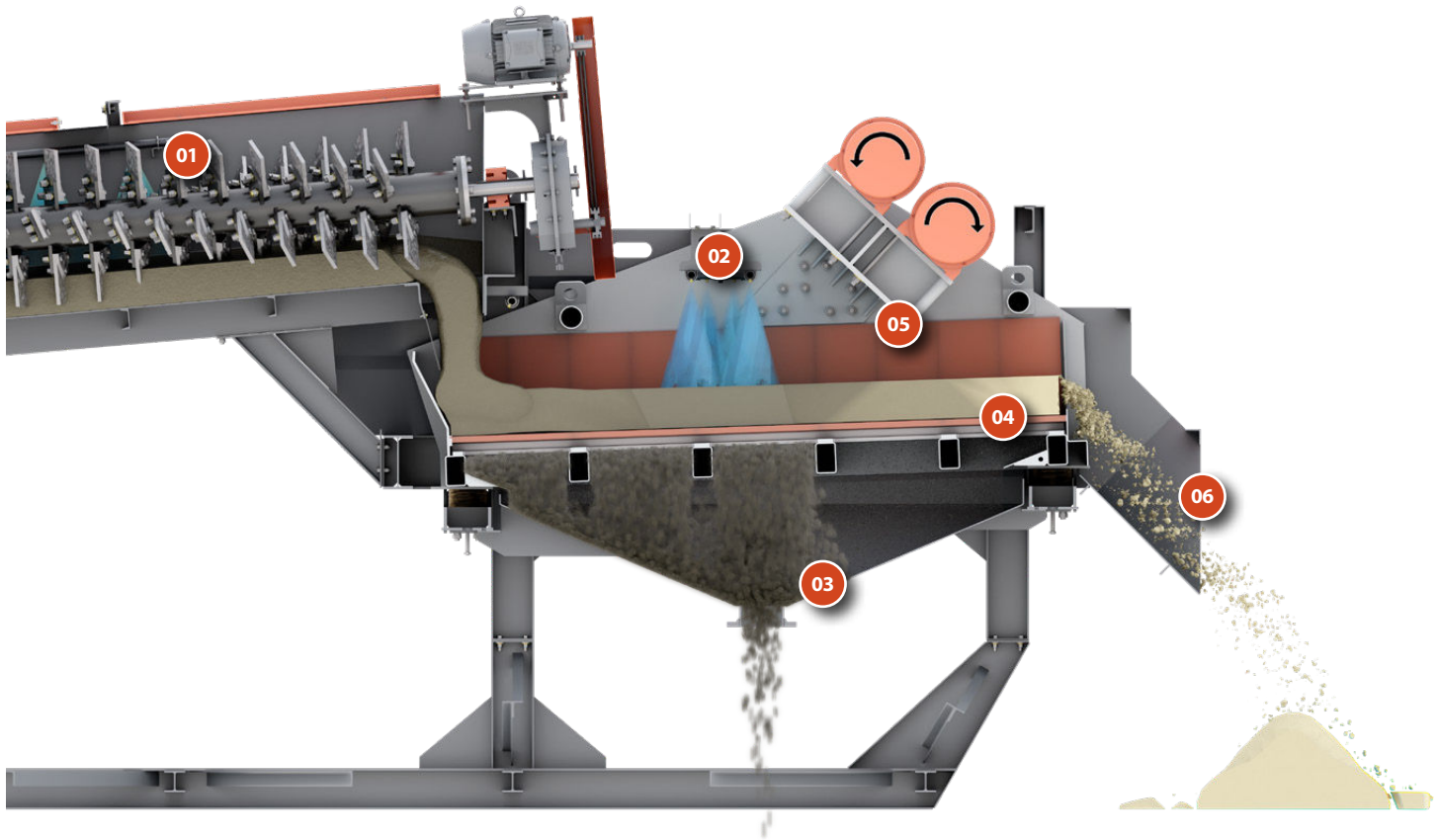

01/ DRY FEED TO AGITATOR

Takes dry feed and turns it into a slurry. Shaft with paddles and water manifold mixes.

02/ SPRAY BARS

Wash out -200 mesh fraction.

03/ FINE TAILINGS DISCHARGE

Includes flanged discharge pipe.

04/ SIDE DEWATERING MEDIA

Unique sidewall media encourages water to drain from top, which produces drier product.

05/ DEWATERING SCREEN

High frequency screen reduces moisture to as low as 8%.

06/ INTEGRATED DISCHARGE CHUTE

Discharges product at 8-12% moisture.

OPTIONS

FLOW VALVE

WALKWAY

SKID FRAME SUPPORT STRUCTURE

FLOW METER (HIGHLY RECOMMENDED)

SAFETY COVERS

FEATURES



01/ DRY FEED TO AGITATOR



02/ SPRAY BARS



03/ FINE TAILINGS DISCHARGE



04/ SIDE MEDIA



05/ DEWATERING SCREEN



06/ DISCHARGE CHUTE

SPECIFICATIONS*

	Capacity*		Max. Material Size		Screen Size		Screw		Horsepower**		Water Consumption		Screen Area		Screen Motor	
	TPH	MTPH	inch	mm	ft	m	in x ft	mm x m	HP	kW	GPM	m ³ /hr	ft ²	m ²	HP	kW
ALLIANCE LOW WATER WASHER																
LWW-410	60 -120	54 -108	1/2"	13	4' x 10'	1.2 x 3.0	30" x 12'	760 x 3.6	29	22	200	45	82	7.7	(two) 7.0	(two) 5.3
LWW-510	90 -180	82 - 164	1/2"	13	5' x 10'	1.5 x 3.0	30" x 12'	760 x 3.6	38	28	300	68	94	8.8	(two) 11.4	(two) 8.6
LWW-612	120 - 240	108 - 216	1/2"	13	6' x 12'	1.8 x 3.6	36" x 12'	915 x 3.6	39	29	400	91	124	11.6	(two) 9.4	(two) 7.1
LWW-712	150 - 300	136 - 272	1/2"	13	7' x 12'	2.1x 3.6	36" x 12'	915 x 3.6	55	41	500	114	137	12.8	(two) 17.4	(two) 13.0

* All capacities are based on a bulk density of 100 lbs/ft³ (1,601.85 kg/m³). ** Combined horsepower for the entire unit.

The performance criteria listed above for the Alliance[®] Low Water Washer, including capacity (feed tons per hour) and finished product gradations, depend on many input parameters (including but not limited to feed gradation and material characteristics). Any variation in the input parameters will affect the performance criteria such that the performance criteria may be outside of the values or ranges listed above. Superior Industries does not guarantee the performance criteria apart from a signed performance guarantee which may be separately issued by superior and based on a detailed study of your application and your commitment to maintain agreed-upon input parameters.

PHOTO GALLERY





FINE MATERIAL WASHER

Typically dewater material to 15-25% moisture in addition to removing silt.



APPLICATIONS

- » Wash, classify and dewater
- » Usually defined as 3/8" or less
- » Unwanted material overflows weirs
- » Heavy material augures up tub
- » Water drains down tub
- » Discharged at 15-25% moisture

FEATURES



01/ SAFEGUARD OUTBOARD BEARING

Off-the-shelf pillow block bearing installed outside tank for protection and easy maintenance. (Not shown)

02/ ADJUSTABLE OVERFLOW WEIR

Encourages overflow water to level, which maximizes fines retention.

03/ LOAD ZONE BAFFLE

Calms water to help maximize fines retention.

04/ VARIETY OF APPLICATION-SPECIFIC SHOES

Manufactured with internal steel plate to hold up in harsh applications.

05/ CURVED BELLY PAN

Eliminates dead spots for material to gather common to 90° angles.

06/ FULLY-GUARDED DRIVE SYSTEM

Utilizes common off-the-shelf, shaft-mounted gear reducer.

07/ HEAVY-DUTY BASE FRAME

Allows for a crane free installation into an existing footprint.

08/ FLUSHBACK NOZZLE

Improves dewatering by removing inactive sand near discharge. (not shown)

OPTIONS

TWIN SCREW

ALLOY STEEL WEAR SHOE

FOLDING WING WALLS

ROAD PORTABLE PACKAGE

MATERIAL DISCHARGE CHUTE

HYDRAULIC DRIVE

REDUCED SCREW SPEED

SAFETY COVERS

ROCK GRADE RUBBER WEAR SHOES

SKID FRAME

FEATURES

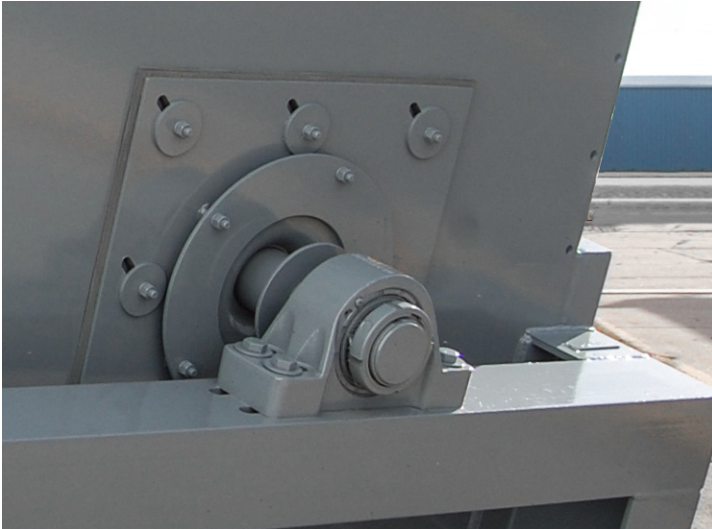

SAFEGUARD OUTBOARD BEARING



OPTION: FLANGE MOUNT BEARING



04/ URETHANE WEAR SHOES



05 / CURVED BELLY PAN



06/ GUARDED DRIVE SYSTEM



08/ FLUSH-BACK NOZZLE

SINGLE SCREW SPECIFICATIONS

Model Number	Screw Diameter		Maximum Material Size		Capacity		Screw Speed rpm	Auger Motor Size		Water Capacity GPM (m ³ /hr)			Estimated Empty Weight		Estimated Operating Weight				
	in	mm	in	mm	stph	mtph		hp	kW	100 Mesh	150 Mesh	200 Mesh	lbs	kg	lbs	kg			
FMW12140BS	12	310	3/8	10	20	19	40	7.5	5.6	150	40	100	30	50	20	2,800	1,280	7,000	3,180
FMW24240BS	24	610	3/8	10	50	46	32	7.5	5.6	500	120	225	60	125	30	7,000	3,180	26,500	12,030
FMW30240BS	30	770	3/8	10	75	69	25	15	11.2	575	140	275	70	160	40	8,600	3,910	28,100	12,750
FMW36250BS	36	920	3/8	10	100	91	20	15	11.2	700	160	330	80	180	50	9,150	4,160	24,950	11,320
FMW3625FBS	36	920	3/8	10	100	91	21	15	11.2	700	160	330	80	180	50	12,742	5,780	29,872	13,550
FMW44320BS	44	1,120	3/8	10	175	160	17	20	15.0	1600	370	750	180	425	100	18,000	8,170	66,000	29,940
FMW4432FBS	44	1,120	3/8	10	175	160	17	25	18.7	1600	370	750	180	425	100	22,200	10,070	70,062	31,780
FMW48350BS	48	1,220	3/8	10	200	182	16	25	18.7	1700	390	850	200	450	110	20,500	9,300	65,500	29,720
FMW54350BS	54	1,380	3/8	10	275	250	15	30	22.4	1900	440	950	220	575	140	23,000	10,440	107,000	48,540
FMW5434FBS	54	1,380	3/8	10	275	250	14	40	29.9	1900	440	950	220	575	140	30,357	13,770	131,285	59,550
FMW60350BS	60	1,530	3/8	10	340	310	13	40	29.9	2200	500	1050	240	600	140	24,500	11,120	125,000	56,700
FMW66350BS	66	1,680	3/8	10	400	364	12	50	37.3	2400	550	1200	280	650	150	36,000	16,330	135,000	61,240
FMW6636FBS	66	1,680	3/8	10	400	364	11	60	44.8	2400	550	1200	280	650	150	40,344	18,300	131,285	59,550
FMW72380BS	72	1,830	3/8	10	475	432	11	60	44.8	2600	590	1300	295	700	159	33,000	14,970	170,000	77,120
FMW84380BS	84	2,140	3/8	10	550	500	9	75	56.0	3100	710	1600	370	850	200	43,000	19,510	190,000	86,190

TWIN SCREW SPECIFICATIONS

Model Number	Screw Diameter		Maximum Material Size		Capacity		Screw Speed rpm	Auger Motor Size		Water Capacity GPM (m ³ /hr)			Estimated Empty Weight		Estimated Operating Weight				
	in	mm	in	mm	stph	mtph		hp	kW	100 Mesh	150 Mesh	200 Mesh	lbs	kg	lbs	kg			
FMW24240BT	(2) 24	610	3/8	10	100	91	40	(2) 7.5	5.6	890	210	420	100	235	60	14,800	6,720	61,000	27,670
FMW30240BT	(2) 30	770	3/8	10	150	137	32	(2) 15	11.2	1,000	230	490	120	280	70	18,350	8,330	76,000	34,480
FMW36250BT	(2) 36	920	3/8	10	200	182	25	(2) 15	11.2	1,250	290	620	150	340	80	17,000	7,720	84,000	38,110
FMW3625FBT	(2) 36	920	3/8	10	200	182	20	(2) 15	11.2	1,250	290	620	150	340	80	21,605	9,800	59,550	27,020
FMW44320BT	(2) 44	1,120	3/8	10	350	319	20	(2) 20	15.0	2,800	640	1,400	320	675	160	30,000	13,610	62,500	28,350
FMW4432FBT	(2) 44	1,120	3/8	10	350	319	17	(2) 25	18.7	2,800	640	1,400	320	675	160	41,777	18,950	134,000	60,790
FMW48350BT	(2) 48	1,220	3/8	10	400	364	17	(2) 25	18.7	3,000	690	1,450	330	750	180	36,000	16,330	112,000	50,810
FMW54350BT	(2) 54	1,380	3/8	10	550	500	16	(2) 30	22.4	3,500	800	1,750	400	950	220	39,650	17,990	117,250	53,190
FMW5434FBT	(2) 54	1,380	3/8	10	550	500	15	(2) 40	29.9	3,500	800	1,750	400	950	220	55,300	25,090	250,000	113,400
FMW60350BT	(2) 60	1,530	3/8	10	680	619	15	(2) 40	29.9	3,700	850	1,800	410	975	230	44,500	20,190	156,000	70,770
FMW66350BT	(2) 66	1,680	3/8	10	800	728	14	(2) 50	37.3	4,000	910	2,000	460	1,200	280	62,500	28,350	158,900	72,080
FMW6636FBT	(2) 66	1,680	3/8	10	800	728	13	(2) 60	44.8	4,000	910	2,000	460	1,200	280	78,000	35,390	250,026	113,410
FMW72380BT	(2) 72	1,830	3/8	10	950	864	11	(2) 75	56.0	4,500	1,030	2,200	500	1,250	290	67,500	30,620	190,000	86,190
FMW7238FBT	(2) 72	1,830	3/8	10	950	864	11	(2) 100	74.6	4,500	1,030	2,200	500	1,250	290	119,000	53,980	344,000	156,040
FMW84380BT	(2) 84	2,140	3/8	10	1,100	1,000	9	(2) 100	74.6	4,800	1,100	2,500	570	1,350	310	70,500	31,980	210,000	95,260

NOTE: Low HP per ton or Superior efficient gearbox uses less HP than traditional fine material washers.



HELIX[®] CYCLONE

Removing unwanted contaminants and recover fines otherwise lost to pond.



APPLICATIONS

- » Removes unwanted silts and clays
- » Reduces fines normally lost to pond
- » Dewateres product

FEATURES

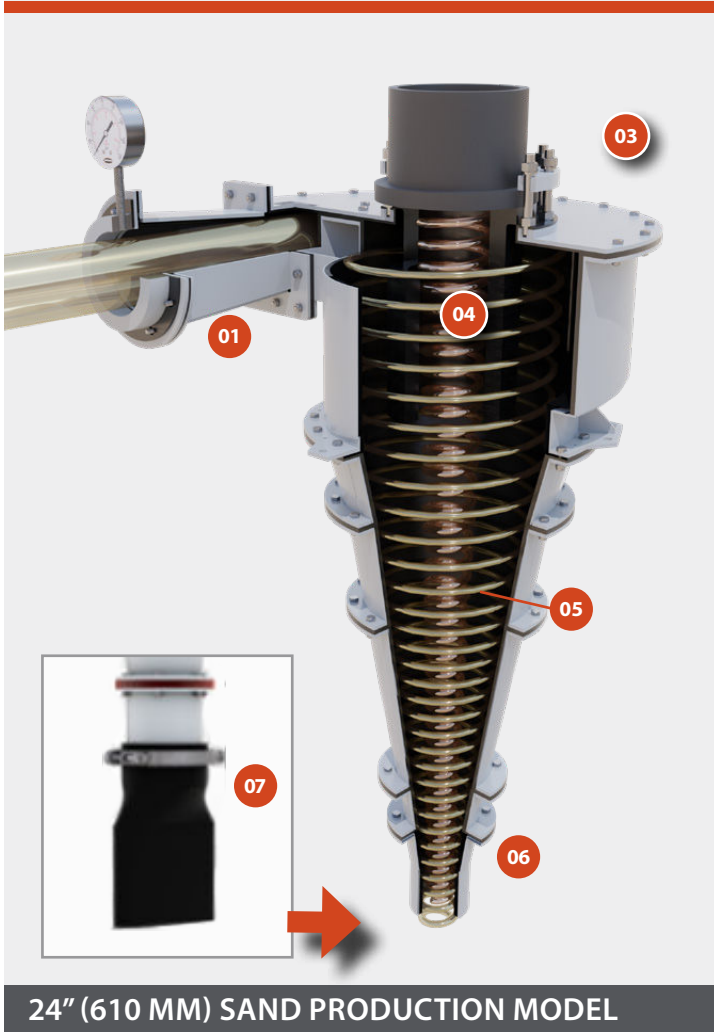

24" (610 MM) SAND PRODUCTION MODEL

01/ FEED PIPE

Square to round transition made of high wear urethane.

02/ GEOMETRICALLY EFFICIENT INLET

Reduces turbulence of feed, which improves classification, and lowers internal wear. Patent pending.

03/ OVERFLOW PIPE

Designed with abrasive-resistant HDPE material.

04/ VORTEX FINDER

Prevents short-circuiting (less misplacement of coarse material to the overflow.)

05/ URETHANE/RUBBER LINING

Fines recovery models cast of 100% urethane, while sand production models have a steel case and urethane or rubber lining to withstand high pressure.

06/ PATENT PENDING APEX

Custom-cut for quick, in-the-field application adjustments.

07/ OPTIONAL SIPHON ASSIST

Typical cyclone discharge is 50-65% solids. The optional siphon assist can reduce discharge moisture as low as 75% solids.



02/ GEOMETRICALLY EFFICIENT INLET



07/ OPTIONAL SIPHON ASSIST

MODELS



SAND PRODUCTION MODELS

- » Structural steel with urethane or rubber liner
- » 200 mesh standard cut point



FINES RECOVERY MODELS

- » Available in 100% cast urethane
- » 400 mesh standard cut point

APPLICATIONS



SIZING

- » Produce necessary cut
- » Reduce water and turbulence for downstream equipment



DEWATER & DESLIME

- » Reduce water/silt to operation
- » Reduce water and turbulence for downstream equipment



FINES RECOVERY

- » Recover 400 mesh plus particles
- » Reduce fines going to pond

SPECIFICATIONS

Model Number	Construction	Cyclone Diameter		Cone Angle	Inlet Diameter		VF Diameter		Inlet Pressure		Flow Rate		% Solids	Feed Capacity	
		in	mm	deg.	in	mm	in	mm	psi	kPa	gpm	m ³ /hr	kg	STPH	MTPH
FINES RECOVERY															
1210CYC	1" (25.4mm) thick Cast Urethane	12	300	10°	4	100	4.6 - 5.8	110 - 140	12 - 25	90 - 400	400 - 750	100 - 180	10%	20	18
1610CYC	1" (25.4mm) thick Cast Urethane	16	400	10°	6	150	6 - 7.6	150 - 190	12 - 25	90 - 800	800 - 1,100	190 - 250	10%	30	27
SAND PRODUCTION															
1220CYC	Structural steel with 1/2" (25mm) thick urethane liner	12	300	20°	4	100	4.6 - 6	110 - 140	10 - 20	70 - 140	400 - 700	100 - 160	20%	40	36
1630CYC	Structural steel with 1/2" (25mm) thick urethane liner	16	400	30°	6	150	6.0 - 8	150 - 190	10 - 20	70 - 140	700 - 1,100	160 - 250	25%	80	73
2030CYC	Structural steel with 1/2" (25mm) thick rubber vs urethane liner	20	500	30°	6	150	7.5 - 9	190 - 230	10 - 20	70 - 140	800 - 1,400	190 - 320	25%	100	91
2430CYC	Structural steel with 1/2" (25mm) thick rubber vs urethane liner	24	600	30°	8	200	8.9 - 11	220 - 280	10 - 20	70 - 140	1,400 - 2,000	320 - 460	25%	150	137
3030CYC	Structural steel with 1/2" (25mm) thick rubber vs urethane liner	30	760	30°	10	250	11.2 - 14	280 - 350	10 - 20	70 - 140	2,200 - 3,400	500 - 780	25%	250	228



SPIRIT® SAND PLANT

Structural package consisting of sump pump, cyclone and dewatering screen.



APPLICATIONS

- » Modular, easy to assemble plant
- » Combination of cyclone, dewatering screen, sumps and pumps
- » Sand production or fines recovery
- » Recover ultrafines from wastewater
- » Reduce solids going to waste pond
- » Consistently produce sharp cuts
- » Ability to ship in container



Rock Face to Load Out™



Patented Technology



DEWATERING SCREEN

+/- 2° ADJUSTABLE DECK

Fine tune the angle of the deck for more or less dewatering.

URETHANE SIDEWALL MEDIA

Remove moisture from top and sides of material for drier product.

3-PIECE ADJUSTABLE DAM

Tunable dam to control bed depth at discharge.

HELIX CYCLONE

FEED INLET

Square to round transition made of high wear urethane.

GEOMETRICALLY EFFICIENT INLET

Reduces turbulence to improve classification and lower internal wear.

OVERFLOW PIPE

Designed with high-wear HDPE material.

VORTEX FINDER

Prevents short-circuiting (less misplacement of coarse material to the overflow).

URETHANE LINING

Fines recovery models cast of 100% urethane or rubber, while sand production models have a steel case and urethane lining.

SUMP TANK

INTERNAL BAFFLE

Reduces turbulence for more consistent, uniform flow.

BOTTOM PLATE

Sloped design allows even material flow to pump.

CLEANOUT FLANGE

Bolt flange design simplifies access for cleanout.

ACCESS PANEL

Removable for easy access to sump.

SUMP AUTO LEVEL

Stand alone automated sump level system with controller, sensor and valve.

FINES RECOVERY SPECIFICATIONS

Model Number	Percent Solids	Flow Rate GPM	Screen Size		Screen Area		Screen Motor		Cyclone Diameter			Pump Size		Pump Motor		Sump Capacity		Total Horsepower	
			m	ft	m ²	ft ²	kW	hp	mm	in	QTY	m	ft	kW	hp	m ³	gal	kW	hp
FR600	0-10%	600	0.9 x 2.4	3 x 8	5.4	110	(2) 5.3	(2) 7.0	310	12	1	150 x 100	6 x 4	22	30	4	1,000	33	44
FR1200	0-10%	1200	0.9 x 2.4	3 x 8	5.4	110	(2) 5.3	(2) 7.0	310	12	2	150 x 100	6 x 4	37	50	4	1,000	48	64
FR1800	0-10%	1800	1.2 x 2.4	4 x 8	6.4	165	(2) 5.3	(2) 7.0	310	12	3	200 x 150	8 x 6	56	75	8	2,000	66	89
FR2700	0-10%	2700	1.2 x 2.4	4 x 8	6.4	165	(2) 5.3	(2) 7.0	410	16	3	250 x 200	10 x 8	75	100	8	2,000	85	114
FR3600	0-10%	3600	1.2 x 2.4	4 x 8	6.4	250	(2) 5.3	(2) 7.0	410	16	4	250 x 200	10 x 8	112	150	11	3,000	122	164
FR4500	0-10%	5400	1.5 x 3.0	5 x 10	8.8	176	(2) 8.6	(2) 11.4	410	16	5	300 x 250	12 x 10	149	200	15	4,000	160	214
FR5400	0-10%	5400	1.5 x 3.0	5 x 10	8.8	250	(2) 8.6	(2) 11.4	410	16	6	350 x 300	14 x 12	149	200	15	4,000	160	214

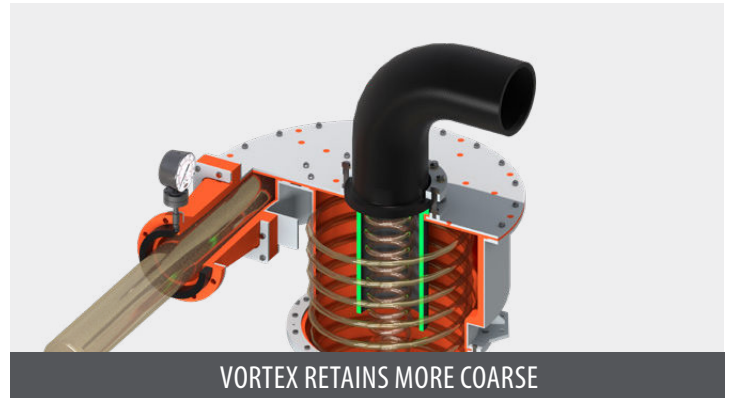

* Patent pending

SAND PRODUCTION SPECIFICATIONS

Model Number	Feed Capacity		Screen Size		Screen Area		Screen Motor		Sump Capacity		Cyclone Diameter		Water Required		Pump Size		Pump Motor		Total Horsepower		
	MTPH	STPH	m	ft	m ²	ft ²	kW	hp	m ³	gal	mm	in	m ³ /hr	gpm	m	ft	kW	hp	kW	hp	
SP70	Standard	64	70	0.9 x 2.4	3 x 8	5.4	58	(2) 5.3	(2) 7.0	3.8	1,000	410	16	160	700	150 x 100	6 x 4	29.9	40	40	54
	High Volume											510	20	230	1,000	150 x 100	6 x 4	37.3	50	48	64
SP100	Standard	91	100	1.2 x 2.4	4 x 8	6.3	68	(2) 5.3	(2) 7.0	7.6	2,000	510	20	230	1,500	150 x 100	6 x 4	56	75	66	89
	High Volume											610	24	350	1,500	200 x 150	8 x 6	56	75	66	89
SP150	Standard	137	150	1.5 x 3.0	5 x 10	8.7	94	(2) 8.6	(2) 11.4	11.4	3,000	610	24	350	1,500	200 x 150	8 x 6	56	75	66	89
	High Volume											770	30	460	2,000	200 x 150	8 x 6	74.6	100	85	114
SP200	Standard	182	200	1.5 x 3.0	5 x 10	8.7	94	(2) 8.6	(2) 11.4	11.4	3,000	510	20	460	2,000	250 x 200	10 x 8	74.6	100	85	114
	High Volume											770	30	690	3,000	250 x 200	10 x 8	74.6	125	104	139
SP300	Standard	273	300	1.8 x 3.6	6 x 12	124	11.5	(2) 7.1	(2) 9.4	15.2	4,000	610	24	690	3,000	250 x 200	10 x 8	74.6	150	122	164
	High Volume											770	30	910	4,000	300 x 250	12 x 10	74.6	150	122	164
SP400	Standard	364	400	2.1 x 3.7	7 x 12	137	12.7	(2) 13.0	(2) 17.4	15.2	4,000	610	24	910	4,000	300 x 250	12 x 10	74.6	200	160	214
	High Volume											770	30	1,140	5,000	350 x 300	14 x 12	74.6	200	160	214





DEWATERING SCREEN

High frequency screen reduces moisture to as low as 8%.



AS LOW AS 8% MOISTURE CONTENT

APPLICATIONS

- » Dewater material
- » Same day product shipping
- » Higher stockpiles; No winter drainage
- » Water passes material/screen media
- » Moisture content as low as 8%

FEATURES



01/ ADJUSTABLE FROM 0 TO 2°

03/ LOW HORSEPOWER

05/ FINES RECOVERY JET (NOT SHOWN)

02/ EASY ADJUST DISCHARGE DAM

04/ URETHANE SCREEN SIDEWALLS

OPTIONS

SUPPORT STRUCTURE

SPRAY BARS

DISCHARGE CHUTE

FINES RECOVERY JET

COLLECTING FLUME

ROAD PORTABLE PACKAGE

FEATURES



OPTIONAL ROAD PORTABLE PACKAGE



02/ ADJUSTABLE DECK (0 - 2°)



04/ URETHANE SCREEN SIDEWALLS

- » Screened side panels
- » More screening surface
- » More tonnage using smaller units
- » Magnetic side panels



05/ FINES RECOVERY JET

- » Return fines to screw via water jet
- » Save 3% of product from ponds
- » Profit earned for quicker payback
- » Integrate into existing equipment
- » Low water requirements (90-100 gpm)
- » Expensive alternative requires sump

DEWATERING SCREEN SPECIFICATIONS*

	Capacity*		Screen Size		Weight		Total Screening Area**		Screen Motor	
	STPH	MTPH	ft	m	lbs.	kg	ft ²	m ²	HP	kW
STANDARD										
3081VBDS	40 - 80	36 - 72	3 x 8	0.9 x 2.4	5,300	2,500	58	5.4	(2) 7.0	(2) 5.3
4081VBDS	60 - 120	54 - 108	4 x 8	1.2 x 2.4	5,700	2,600	68	6.4	(2) 7.0	(2) 5.3
4101VBDS	60 - 120	54 - 108	4 x 10	1.2 x 3.0	6,500	3,000	82	7.7	(2) 7.0	(2) 5.3
5101VBDS	100 - 200	91 - 182	5 x 10	1.5 x 3.0	8,200	3,800	94	8.8	(2) 11.4	(2) 8.6
6101VBDS	150 - 300	136 - 272	6 x 10	1.8 x 3.0	9,000	4,100	106	9.9	(2) 9.4	(2) 7.1
6121VBDS	150 - 300	136 - 272	6 x 12	1.8 x 3.6	10,000	4,600	124	11.6	(2) 9.4	(2) 7.1
7121VBDS	200 - 400	182 - 364	7 x 12	1.2 x 3.6	11,000	5,000	137	12.8	(2) 17.4	(2) 13.0
LOW PROFILE										
3081VBDSLPL	40 - 80	36 - 72	3 x 8	0.9 x 2.4	5,000	2,300	47	4.4	(2) 7.0	(2) 5.3
4081VBDSLPL	60 - 120	54 - 108	4 x 8	1.2 x 2.4	5,500	2,500	57	5.3	(2) 7.0	(2) 5.3
5101VBDSLPL	100 - 200	91 - 182	5 x 10	1.5 x 3.0	8,000	3,700	81	7.6	(2) 11.4	(2) 5.3

*All capacities are based on a bulk density of 100 lbs/ft³ (1,601.85 kg/m³).

** Total screening area is the sum of the bottom, angled and side deck area which allows for maximum drainage of moisture.

The performance criteria listed above for the dewatering screen, including capacity (finished tons per hour) and finished product gradations, depend on many input parameters (including but not limited to feed gradation and material characteristics). Any variation in the input parameters will affect the performance criteria such that the performance criteria may be outside of the values or ranges listed above. Superior Industries does not guarantee the performance criteria apart from a signed performance guarantee which may be separately issued by superior and based on a detailed study of your application and your commitment to maintain agreed-upon input parameters.

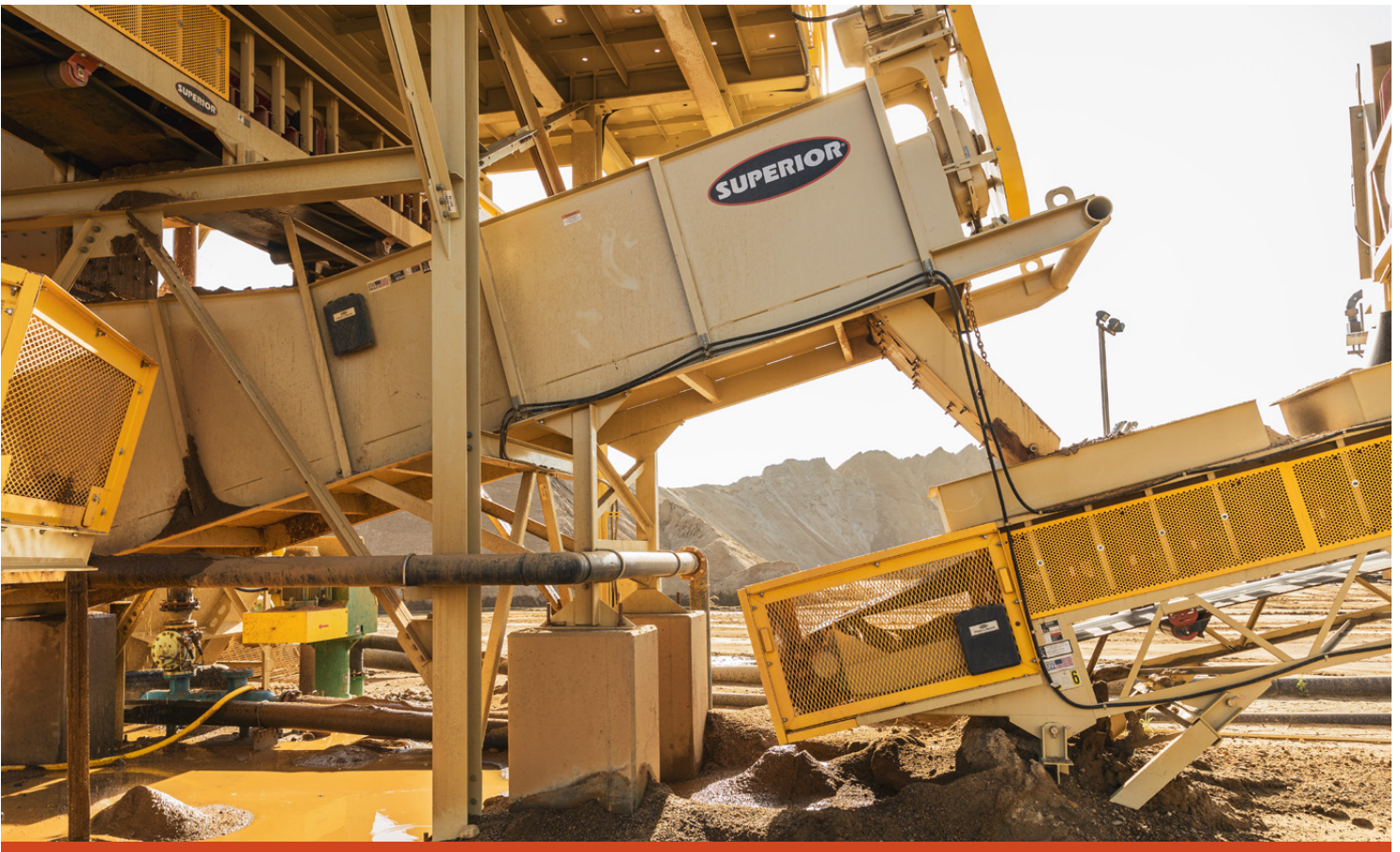

COARSE MATERIAL WASHER

Mildly scrubs material greater than 3/4" while removing unwanted material.



APPLICATIONS

- » Remove dust from rock surface
- » Remove sand from feed
- » Unwanted/Deleterious overflow weirs
- » Mild scrubbing of stone and gravel
- » Section of paddles then flights
- » No overlapping of paddles
- » Coarse is usually defined >3/4"

FEATURES



01/ SAFEGUARD OUTBOARD BEARING

Off-the-shelf pillow block bearing installed outside tank for protection and easy maintenance. (Not shown)

02/ ADJUSTABLE OVERFLOW GATE

Allows control of water bed depth for cleaner, drier product.

03/ ALLOY STEEL WEAR PADDLES AND SHOES

Abrasion-resistant cast iron used specifically for mining and earth-handling industries. Guaranteed hardness ensures quality.

04/ SPIRAL FLIGHTS

Moves gravel up incline

05/ CURVED BELLY PAN

Eliminates dead spots for material to gather common to 90° angles.

06/ FULLY-GUARDED DRIVE SYSTEM

Utilizes common off-the-shelf, shaft-mounted gear reducer.

OPTIONS

ADDITIONAL REVOLUTIONS OF PADDLES

DISCHARGE CHUTE

HYDRAULIC DRIVE

URETHANE WEAR SHOES

BOLT-ON PADDLE BASES

SAFETY COVERS

ROAD PORTABLE PACKAGE

FEATURES

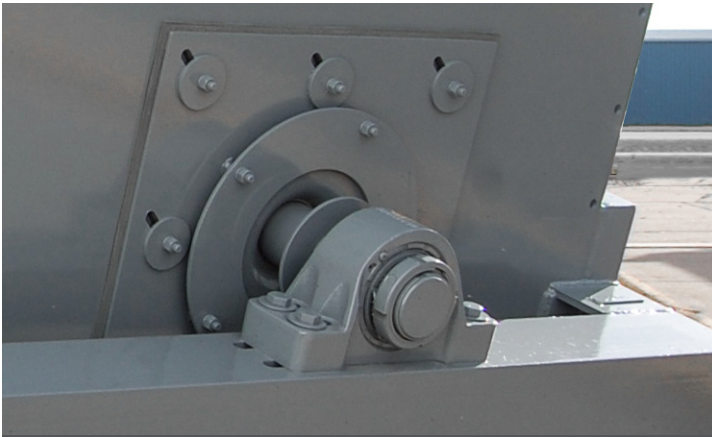

OPTION: SAFEGUARD OUTBOARD BEARING



OPTION: FLANGE MOUNT BEARING



ABRASION-RESISTANT A-532 WEAR PADDLES



CURVED BELLY PAN



FULLY-GUARDED DRIVE SYSTEM

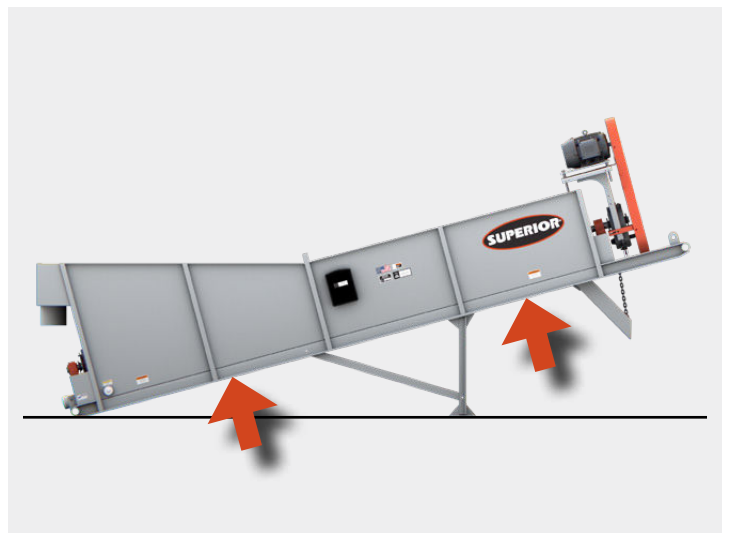

RIGID SKID

SINGLE SCREW SPECIFICATIONS

Model Number	Screw Diameter		Maximum Material Size		Capacity		Screw Speed		Motor			Water Capacity		Empty Weight		Loaded Weight	
	in.	mm	in.	mm	stph	mtph	fpm	rpm	hp	kW	rpm	GPM	m ³ /hr	lbs.	kg	lbs.	kg
CMW24180BS	24	610	1.5	38	60 - 75	55 - 69	120	40	15	11	1,750	300 - 400	70 - 100	8,000	3,630	23,000	10,440
CMW30180BS	30	770	2.0	51	100 - 125	91 - 114	300	37	20	15	1,750	300 - 500	70 - 120	9,000	4,090	27,000	12,250
CMW30240BS	30	770	2.0	51	100 - 125	91 - 114	300	37	25	19	1,750	250 - 500	60 - 120	10,700	4,860	33,700	15,290
CMW36180BS	36	920	3.0	76	150 - 175	137 - 160	300	30	25	19	1,750	400 - 600	100 - 140	11,300	5,130	35,300	16,020
CMW3618FBS	36	920	2.4	60	149 - 176	136 - 160	300	32	30	22	1,750	400 - 600	100 - 140	12,544	5,690	35,300	16,020
CMW36280BS	36	920	3.0	76	150 - 175	137 - 160	300	30	30	22	1,750	400 - 600	100 - 140	14,400	6,540	49,500	22,460
CMW44200BS	44	1,120	3.0	76	200 - 250	182 - 228	300	26	30	22	1,750	500 - 750	120 - 180	15,000	6,810	47,000	21,320
CMW4420FBS	44	1,120	3.0	75	200 - 250	182 - 228	300	26	40	30	1,750	500 - 750	120 - 180	18,584	8,430	36,574	16,590
CMW44320BS	44	1,120	3.0	76	200 - 250	182 - 228	300	26	50	37	1,750	500 - 750	120 - 180	19,300	8,760	67,300	30,530
CMW48240BS	48	1,220	3.5	89	200 - 250	182 - 228	300	24	30	22	1,750	500 - 750	120 - 180	N/A	N/A	N/A	N/A
CMW48320BS	48	1,220	3.5	89	220 - 275	200 - 250	300	24	40	30	1,750	500 - 750	120 - 180	N/A	N/A	N/A	N/A

TWIN SCREW SPECIFICATIONS

Model Number	Screw Diameter		Maximum Material Size		Capacity		Screw Speed		Motor			Water Capacity		Empty Weight		Loaded Weight	
	in.	mm	in.	mm	stph	mtph	fpm	rpm	hp	kW	rpm	GPM	m ³ /hr	lbs.	kg	lbs.	kg
CMW30180BT	(2) 30	770	2.0	51	200 - 250	182 - 227	300	37	(2) 20	(2) 15	1,750	500 - 700	120 - 160	13,700	6,220	48,700	22,090
CMW30240BT	(2) 30	770	2.0	51	200 - 250	182 - 227	300	37	(2) 25	(2) 19	1,750	600 - 1,000	140 - 230	19,300	8,760	65,300	29,620
CMW36180BT	(2) 36	920	3.0	76	250 - 300	227 - 273	300	30	(2) 25	(2) 19	1,750	700 - 1,200	160 - 280	17,000	7,720	65,000	29,490
CMW3618FBT	(2) 36	920	2.4	60	285 - 315	314 - 347	300	32	(2) 30	(2) 22	1,750	700 - 1,200	160 - 280	22,640	10,270	36,574	16,590
CMW36280BT	(2) 36	920	3.0	76	250 - 300	227 - 273	300	30	(2) 25	(2) 19	1,750	700 - 1,200	160 - 280	23,000	10,440	72,000	32,660
CMW44200BT	(2) 44	1,120	3.0	76	450 - 500	409 - 455	300	26	(2) 30	(2) 22	1,750	1,000 - 1,500	230 - 350	28,500	12,930	95,500	43,320
CMW4420FBT	(2) 44	1,120	3.0	75	397 - 496	360 - 450	300	26	(2) 40	(2) 30	1,750	1,000 - 1,500	230 - 350	34,480	15,640	49,912	22,640
CMW44320BT	(2) 44	1,120	3.0	76	450 - 500	409 - 455	300	26	(2) 30	(2) 22	1,750	1,000 - 1,500	230 - 350	39,600	17,970	136,000	61,690
CMW48240BT	(2) 48	1,220	3.5	89	450 - 500	409 - 455	300	24	(2) 30	(2) 22	1,750	1,000 - 1,500	230 - 350	N/A	N/A	N/A	N/A
CMW48320BT	(2) 48	1,220	3.5	89	450 - 500	409 - 455	300	24	(2) 40	(2) 30	1,750	1,000 - 1,500	230 - 350	N/A	N/A	N/A	N/A



BLADE MILL WASHER

Dry feed converted to slurry for screening efficiency.



APPLICATIONS

- » Liquifies material before screening
- » Improves screening efficiency up to 15%
- » Improves sand equivalency (SE)
- » Break up soluble clay, mud, silt or soil
- » Remove organic materials

FEATURES

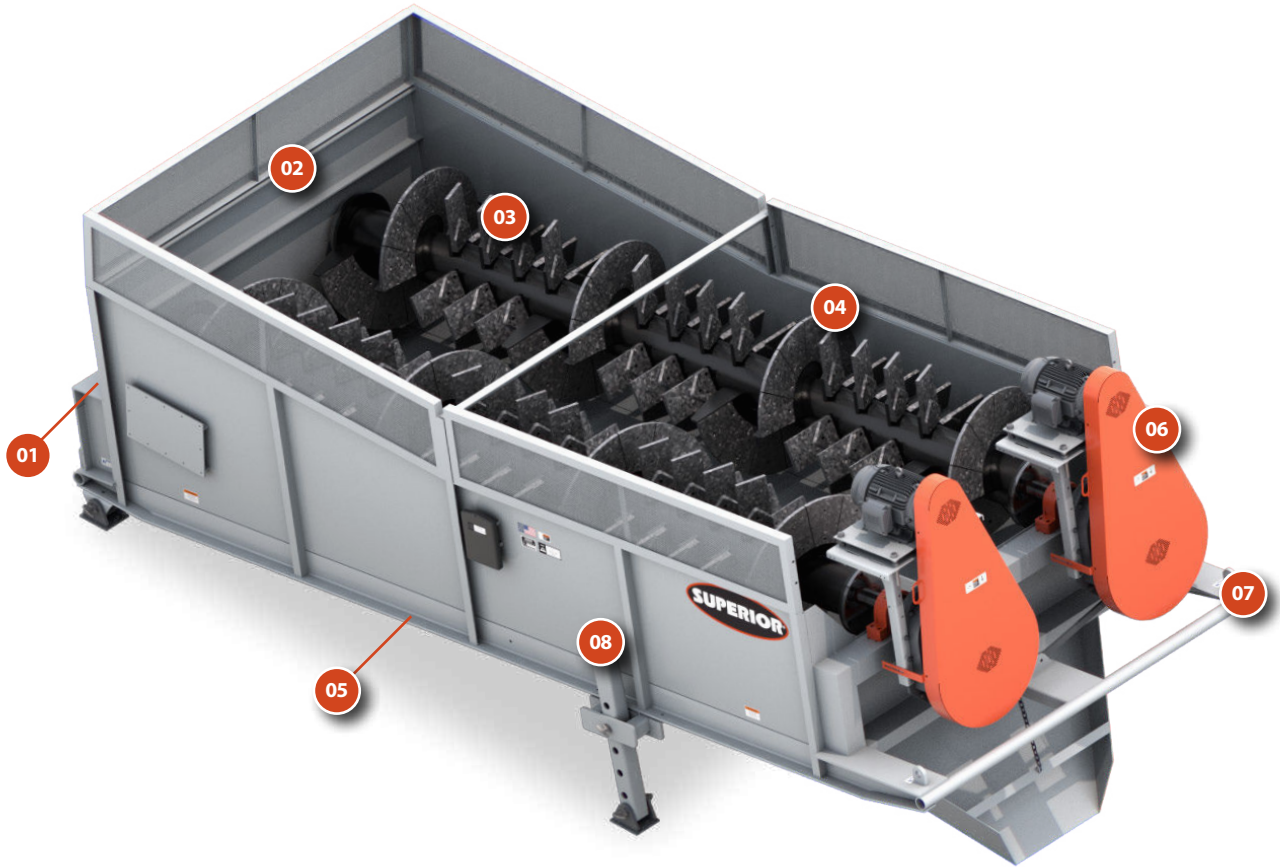

01/ SAFEGUARD OUTBOARD BEARING

Off-the-shelf pillow block bearing installed outside tank for protection and easy maintenance. (Not shown)

02/ ADJUSTABLE OVERFLOW GATE

Allows control of water bed depth for cleaner, drier product.

03/ ALLOY STEEL WEAR PADDLES AND SHOES

Abrasion-resistant cast iron used specifically for mining and earth-handling industries. Guaranteed hardness ensures quality.

04/ SPIRAL FLIGHTS

Moves gravel up incline

05/ CURVED BELLY PAN

Eliminates dead spots for material to gather common to 90° angles.

06/ FULLY-GUARDED DRIVE SYSTEM

Utilizes common off-the-shelf, shaft-mounted gear reducer.

07/ RIGID SKID

Allows for easy assembly.

08/ OPTIONAL ADJUSTABLE LEGS

OPTIONS

ADDITIONAL REVOLUTIONS OF PADDLES

DISCHARGE CHUTE

HYDRAULIC DRIVE

URETHANE WEAR SHOES

BOLT-ON PADDLE BASES

SAFETY COVERS

FEATURES

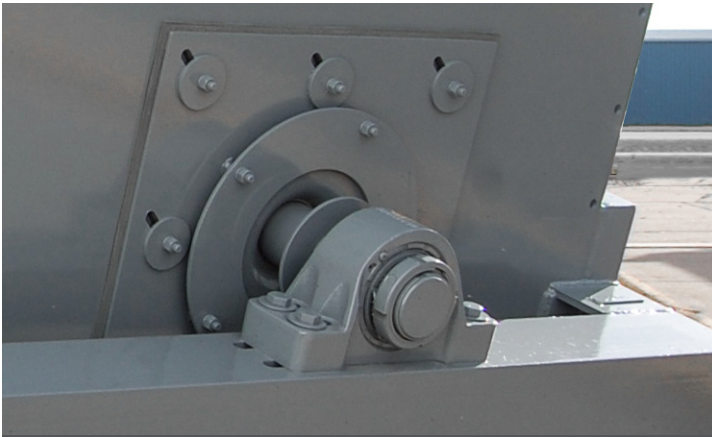

OPTION: SAFEGUARD OUTBOARD BEARING



OPTION: FLANGE MOUNT BEARING



ABRASION-RESISTANT A-532 WEAR PADDLES



CURVED BELL Y PAN



FULLY-GUARDED DRIVE SYSTEM

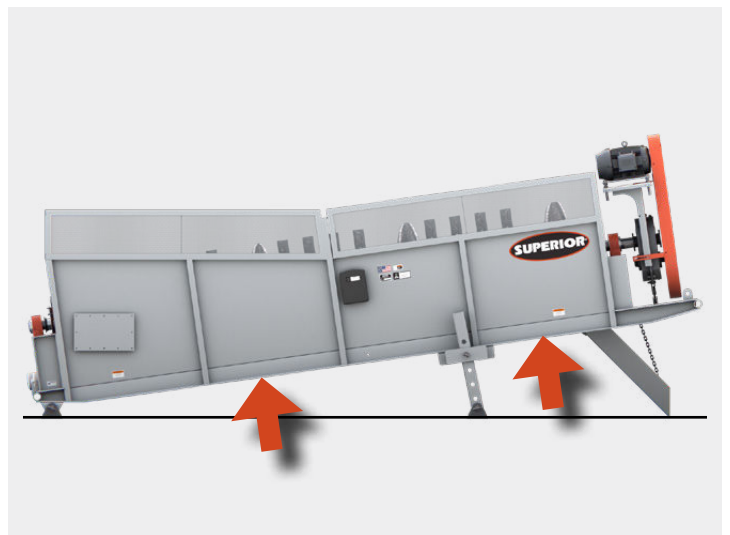

RIGID SKID

SINGLE SHAFT SPECIFICATIONS

Model Number	Screw Diameter		Max Material Size		Operating Angle	Fixed Legs	Ad-just. Legs	Capacity		Screw Speed	Motor			Water Capacity		Empty Weight		Loaded Weight	
	in	mm	in	mm				stph	mtph		rpm	hp	kW	rpm	GPM	m ³ /hr	lbs	kg	lbs
BMW24180BS	24	610	1.5	38	2°-8°	8°	2°-8°	60 - 110	55 - 100	40	15	11	1,750	120 - 130	28-75	7,000	3,180	20,000	9,080
BMW24240BS	24	610	1.5	38	2°-8°	8°	2°-8°	60 - 110	55 - 100	40	20	15	1,750	120 - 330	28-75	7,800	3,540	24,800	11,250
BMW30180BS	30	770	2.0	51	2°-8°	8°	2°-8°	100 - 165	91 - 150	37	20	15	1,750	200 - 495	46-113	9,500	4,310	26,500	12,030
BMW30240BS	30	770	2.0	51	2°-8°	8°	2°-8°	100 - 165	91 - 150	37	25	19	1,750	200 - 495	46-113	10,600	4,810	32,600	14,790
BMW36180BS	36	920	3.0	76	2°-8°	8°	2°-8°	150 - 250	137 - 228	30	25	19	1,750	300 - 750	69-171	11,000	4,990	34,000	15,430
BMW3618FBS	35.5	900	2.5	63	4°-6°	6°	N/A	148 - 176	135 - 160	32	40	30	1,750	296 - 598	68-120	12,125	5,500	30,423	13,800
BMW36280BS	36	920	3.0	76	2°-8°	8°	2°-8°	150 - 250	137 - 228	30	30	22	1,750	300 - 750	69-171	14,000	6,360	48,000	21,780
BMW44200BS	44	1,120	3.5	89	2°-8°	8°	2°-8°	200 - 335	182 - 305	26	26	19	1,750	400 - 1,005	91-229	15,000	6,810	44,000	19,960
BMW4420FBS	43.3	1,100	3.0	75	4°-6°	6°	N/A	198 - 248	180 - 225	26	50	37	1,750	396 - 744	90-169	20,635	9,360	36,574	16,590
BMW44320BS	44	1,120	3.5	89	2°-8°	8°	2°-8°	200 - 335	182 - 305	26	50	37	1,750	400 - 1,005	91-229	19,500	8,850	64,500	29,260
BMW48240BS	48	1,220	3.5	89	2°-8°	8°	2°-8°	220 - 360	200 - 328	24	40	30	1,750	440 - 1,080	100-246	15,000	6,810	44,000	19,960

TWIN SHAFT SPECIFICATIONS

Model Number	Screw Diameter		Max Material Size		Operating Angle	Fixed Legs	Ad-just. Legs	Capacity		Screw Speed	Motor			Water Capacity		Empty Weight		Loaded Weight	
	in	mm	in	mm				stph	mtph		rpm	hp	kW	rpm	GPM	m ³ /hr	lbs	kg	lbs
BMW30180BT	(2) 30	770	2.0	51	2°-8°	8°	2°-8°	120 - 220	110 - 200	37	(2) 20	15	1,750	240 - 660	55 - 150	14,000	6,360	48,000	21,780
BMW30240BT	(2) 30	1,120	2.0	51	2°-8°	8°	2°-8°	120 - 220	110 - 200	37	(2) 25	19	1,750	240 - 660	55 - 150	19,300	8,760	59,000	26,770
BMW36180BT	(2) 36	920	3.0	76	2°-8°	8°	2°-8°	300 - 500	273 - 455	30	(2) 25	19	1,750	600 - 1,500	137 - 341	17,800	8,080	62,800	28,490
BMW3618FBT	(2) 35.5	900	2.5	63	4°-6°	6°	N/A	315 - 350	285 - 315	32	(2) 30	22	1,750	630 - 1,050	144 - 239	22,046	10,000	49,912	22,640
BMW36280BT	(2) 36	920	3.0	76	2°-8°	8°	2°-8°	300 - 500	273 - 455	30	(2) 30	22	1,750	600 - 1,500	137 - 341	23,000	10,440	79,310	35,980
BMW44200BT	(2) 44	1,120	3.5	89	2°-8°	8°	2°-8°	400 - 670	364 - 610	26	(2) 30	22	1,750	800 - 2,010	182 - 457	30,000	13,610	80,000	36,290
BMW4420FBT	(2) 43.3	1,100	3.0	75	4°-6°	6°	N/A	400 - 500	360 - 450	26	(2) 50	37	1,750	800 - 1,500	182 - 341	34,480	15,640	69,136	31,360
BMW44320BT	(2) 44	1,120	3.5	89	2°-8°	8°	2°-8°	400 - 670	364 - 610	26	(2) 50	37	1,750	800 - 2,010	182 - 457	36,600	16,610	122,000	55,340
BMW48240BT	(2) 48	1,220	3.5	89	2°-8°	8°	2°-8°	440 - 720	400 - 655	24	(2) 50	37	1,750	880 - 2,160	200 - 491	39,600	17,970	120,000	54,440
BMW60320BT	(2) 60	1,530	5.0	127	2°-8°	8°	2°-8°	610 - 1,000	555 - 909	22	(2) 75	56	1,750	1,220 - 3,000	278 - 682	53,050	24,070	81,000	36,750



LOG WASHER

Aggressively scrubs toughest clays from rocks.



APPLICATIONS

- » Remove toughest, plastic clays
- » Dissolved clays overflow weir
- » Most aggressive scrubbing action
- » Paddles overlap each others' paths
- » Material-on-material scrubbing

FEATURES



01/ SAFEGUARD OUTBOARD BEARING

Off-the-shelf pillow block bearing installed outside tank for protection and easy maintenance. (Not shown)

02/ ADJUSTABLE OVERFLOW GATE

Allows control of water bed depth for cleaner, drier product.

03/ TWIN SHAFTS WITH A-532 WEAR PADDLES

Abrasion-resistant cast iron used specifically for mining and earth-handling industries. Guaranteed hardness ensures quality.

04/ OPTIONAL ADJUSTABLE LEGS

05/ FULLY-GUARDED DRIVE SYSTEM

Utilizes common off-the-shelf, shaft-mounted gear reducer.

06/ RIGID SKID

Rigid construction reduces fatigue adding machine life.

OPTIONS

ADJUSTABLE SUPPORT LEGS (2° - 10°)

DISCHARGE CHUTE

ROAD PORTABLE PACKAGE

FIXED LEGS

SAFETY COVER

CLEAN OUT DOORS

FEATURES

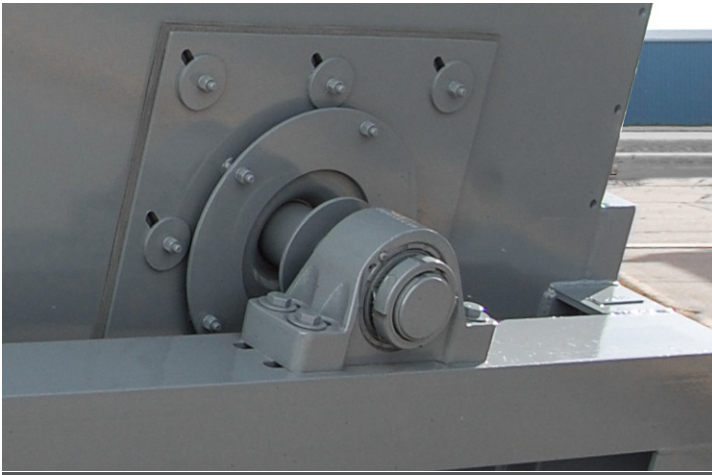

OPTION: SAFEGUARD OUTBOARD BEARING



OPTION: FLANGE MOUNT BEARING



LOG SHAFT (WITH A532 PADDLES)



ADJUSTABLE OVERFLOW GATE



FULLY-GUARDED DRIVE SYSTEM



RIGID SKID

SPECIFICATIONS

Model Number	Screw Diameter		Max Material Size		Operating Angle	Capacity		Water		Screw Speed	Motor		Empty Weight		Loaded Weight	
	inch	mm	inch	mm		stph	mtph	gpm	m ³ /h		rpm	hp	kW	lbs	kg	lbs
LGW24200BT	24	610	2.0	51	6°-10°	30 - 60	28 - 55	15 - 60	4 - 14	40	40	30	30,000	13,610	52,500	23,820
LGW36250BT	36	914	3.0	76	6°-10°	50 - 125	46 - 114	25 - 125	6 - 29	33	75	56	33,500	15,200	90,000	40,830
LGW36300BT	36	914	3.0	76	6°-10°	50 - 125	46 - 114	25 - 125	6 - 29	33	100	75	38,500	17,470	106,000	48,090
LGW36350BT	36	914	3.0	76	6°-10°	50 - 125	46 - 114	25 - 125	6 - 29	33	150	112	48,000	21,780	123,000	55,800
LGW38300BT	38	965	2.5	64	6°-10°	50 - 140	46 - 128	30 - 140	7 - 32	33	125	93	41,000	18,600	108,500	49,220
LGW38350BT	38	965	2.5	64	6°-10°	60 - 140	69 - 128	30 - 140	7 - 32	33	150	112	47,500	5,500	126,000	5,500
LGW44250BT	44	1,118	4.0	102	6°-10°	75 - 175	69 - 160	38 - 175	9 - 40	26	150	112	48,000	21,780	148,000	67,140
LGW44300BT	44	1,118	4.0	102	6°-10°	75 - 175	69 - 160	38 - 175	9 - 40	26	150	112	57,000	25,860	148,000	67,140
LGW44350BT	44	1,118	4.0	102	6°-10°	75 - 175	69 - 160	38 - 175	9 - 40	26	200	149	71,000	9,360	164,000	9,360
LGW46300BT	46	1,168	3.5	89	6°-10°	100 - 190	91 - 173	50 - 190	12 - 44	26	200	149	61,000	27,670	151,000	68,500
LGW46350BT	46	1,168	3.5	89	6°-10°	100 - 190	91 - 173	50 - 190	12 - 44	26	200	149	74,000	33,570	167,000	75,750



ATTRITION MILL

Surface cleaning and polishing, plus breaks up of bonded clusters.

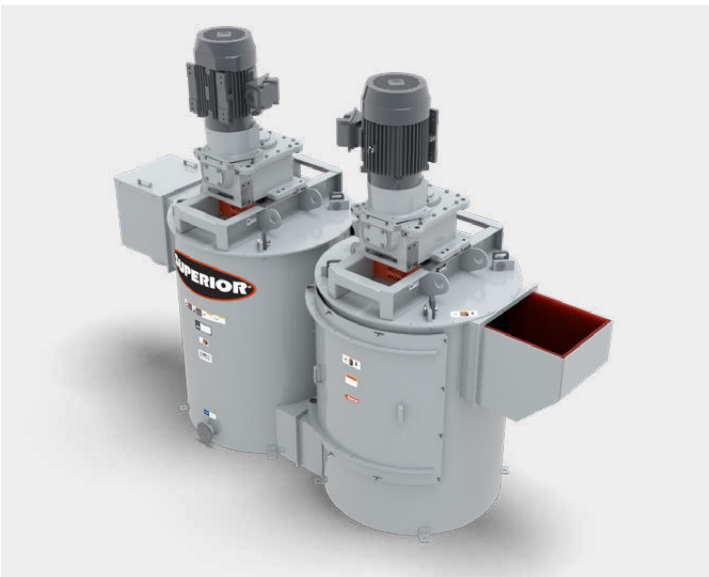

APPLICATIONS

- » Surface scrubbing and polishing
- » Break up bonded clusters
- » Help meet turbidity/color requirements
- » Material on material attrition
- » Fully modular design
- » Link to increase retention time

FEATURES

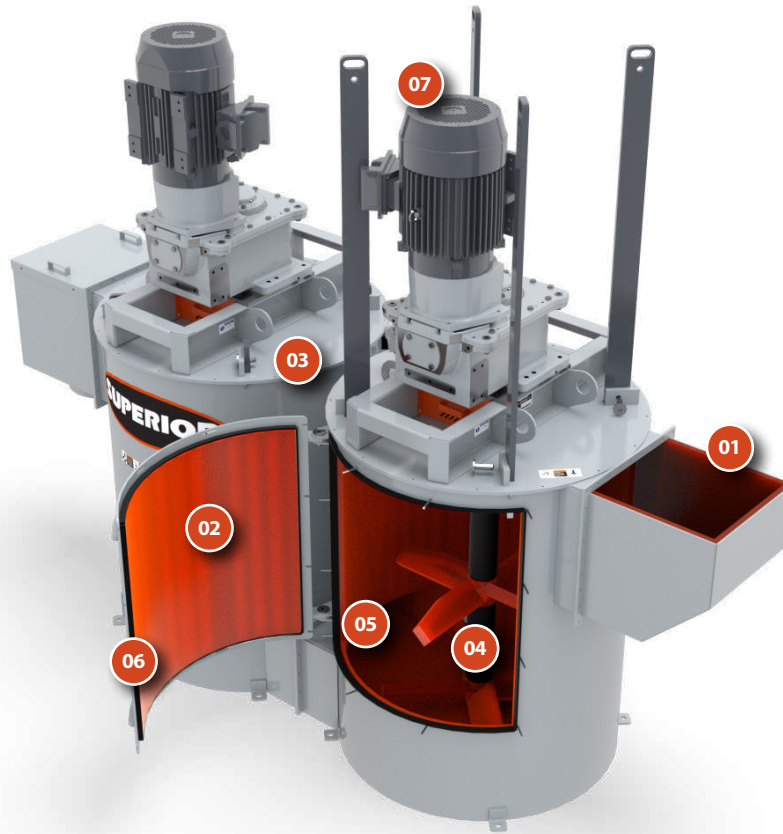

01/ LINED FEEDBOX

Lined with replaceable urethane panels.

02/ LONG-LASTING WEAR LINERS

Standard 1" (25mm) weld in liners or optional replaceable bolt in style.

03/ STEEL BAFFLES

Optimize material flow and pin or unpin for easy replacement.

04/ IMPELLER

Toolless attachments are coated in 1/4" (6.4mm) of urethane.

05/ BAFFLES

Coated in 1/4" urethane.

06/ ACCESS DOOR

Extra large hinged access door with gasket seal.

07/ DIRECT DRIVE

Reduces maintenance, electricity and lowers operating cost.

FEATURES



DRIVE

- » Purpose designed for mixing
- » Accessible to external maintenance
- » Rebuildable driveshaft:
 - » No need to remove top cover
 - » Motor and gearbox can stay too
 - » Assembled without fasteners
 - » No rusting of components

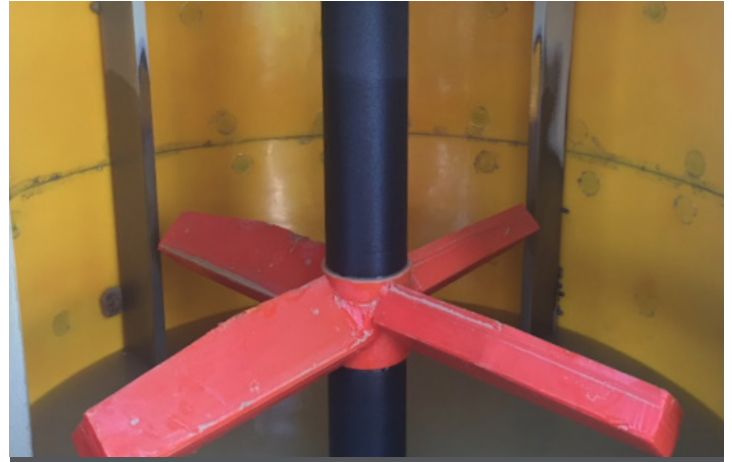

MAINTENANCE

- » Sealed doors allow internal access
- » No need to remove top cover
- » Weld or bolt in 1" thick liners
- » Remove baffles with one pin
- » Convenient lift points to remove drive

SPECIFICATIONS

Outside Diameter (mm)	54" (1,370)
Tank Height* (mm)	72" (1,830)
Feed Rate (65% Solids)	75-150 TPH (68-136 MTP) 3.5 to 1.8 min retention time
Feed Rate (80% Solids)	75-150 TPH (68-136 MTP) 5 to 2.5 min retention time
Inlet urethane lined (mm)	24" x 24" (610 x 610)

Outlet urethane lined (mm)	16" (405)
Inspection Door (mm)	42" x 42" (1,065 x 1,065)
Cleanout Pipe (mm)	3" flanged (75)
Impellers (mm)	2" urethane coating (50)
Overflow Weir	Adjustable

* Additional tanks can be linked for longer retention time



PUGMILL MIXER

Produce a continuous homogeneous mixture or blend of material and additives.



APPLICATIONS

- » Mix gravel, limestone and aggregate
- » Production of:
 - » Stabilized road base
 - » Cement treated base (CTB)
 - » Cold-mix
- » Portable or stationary equipment

OPERATING SPECIFICATIONS

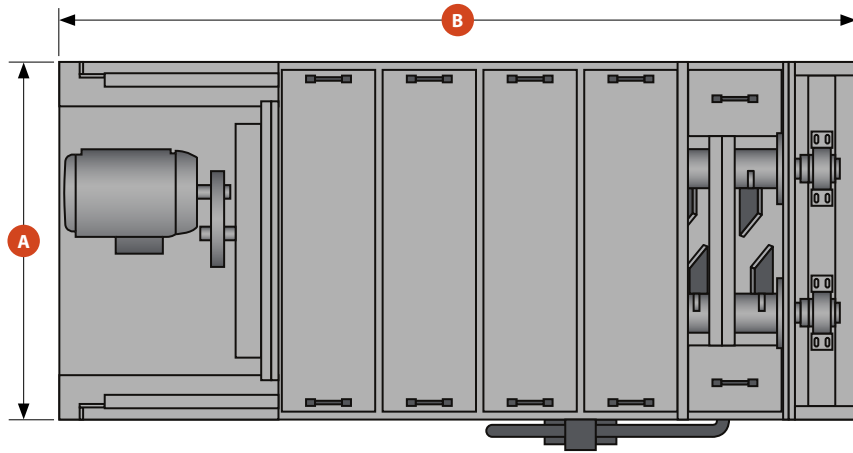

top view

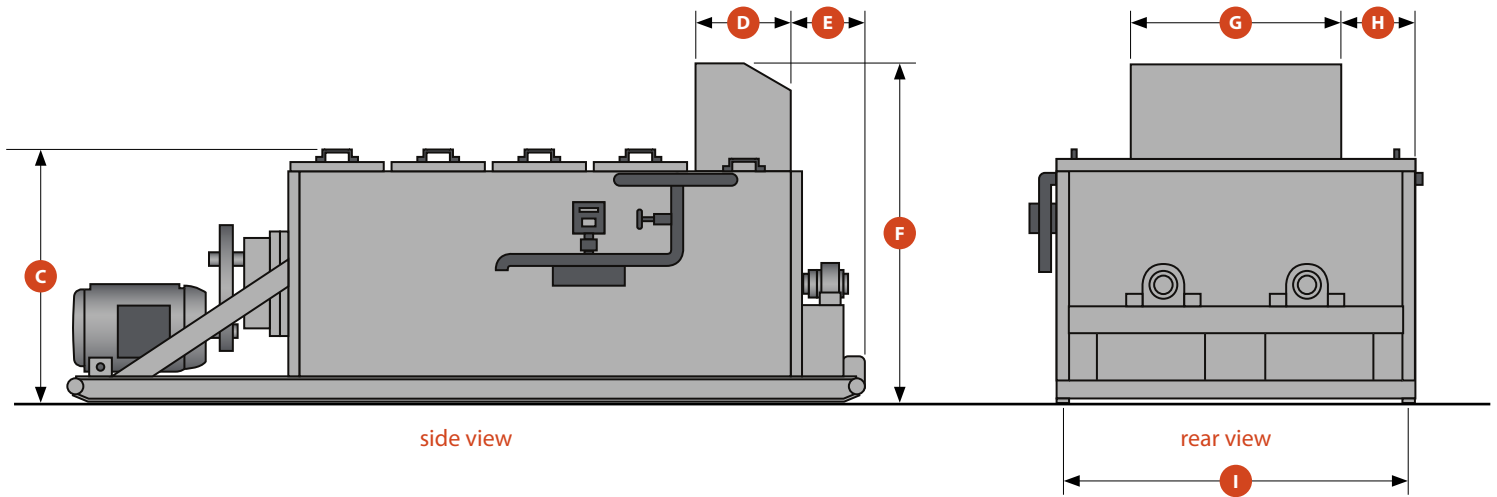

side view

rear view

Pugmill Mixer Dimensions - Inches (mm)

	A	B	C	D	E	F	G	H	I
36 x 9	80 (2,032)	177 (4,500)	55 (1,397)	21 (535)	17 (430)	75 (1,905)	47 (1,195)	17 (430)	77 (1,955)
44 x 12	97 (2,463)	210 (5,334)	58 (1,473)	21 (535)	17 (430)	80 (2,032)	47 (1,195)	25 (635)	91 (2,311)

	36" x 9' Pugmill Mixer	44" x 12' Pugmill Mixer
Shaft Speed RPM	33	26
Capacity TPH (MTPH)	350 -750 (315-680)	600-1,200 (545-1,090)
Motor HP (kW)	100 (75)	150 (110)



CONCRETE WASHOUT SYSTEM

Recovery of sellable aggregate from ready-mix trucks.



RECYCLED MATERIAL IS NEW PROFIT

APPLICATIONS

- » Recover sand from ready-mix trucks
- » Avoid wasteful disposal
- » Eliminate trips to disposal site
- » Reduce washdown time
- » Multiple trucks discharge at once

FEATURES

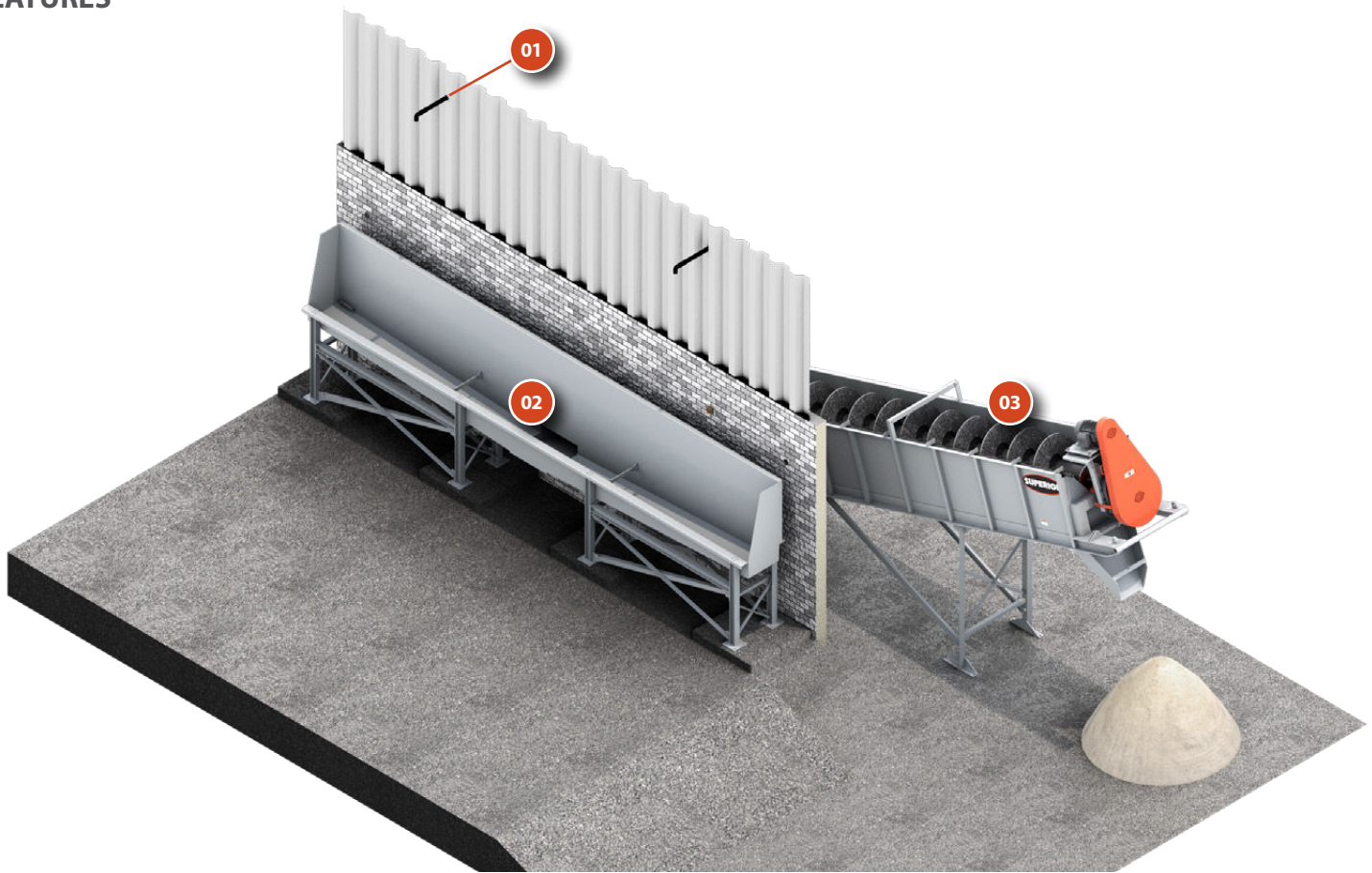

01/ WATER PUMP

Includes 4" (101mm) water pumps, hoses and motor. Designed for front or rear truck hopper.

02/ CLEANOUT HOPPER

Front or rear discharge configurations to accommodate 2-4 trucks at one time.

03/ FINE MATERIAL WASHER

Scrubbs away any cement to produce reusable aggregate material at up to 2.2 yd/min (2.0 m/min).

CONCRETE WASHOUT SYSTEM SPECIFICATIONS

Screw Size in x ft (mmxmm)	Processing Time yrd/min (m/min)	Screw Speed RPM	Motor Size HP (kW)	Length ft (m)	Estimated Empty Weight lbs (kg)	Screw Diameter inch (mm)
GENERAL						
36" x 25' (915 x 8)	1.2 (1.0)	20	15 (11.0)	25' (8.0)	10,800 (4,900)	36" (915)
44" x 32' (1,120 x 10)	2.2 (2.0)	17	20 (15.0)	32' (10.0)	16,800 (7,620)	44" (1,120)



superior-ind.com



ROCK FACE TO
LOAD OUT[™]
superior-ind.com

2022-129SPLT1133ENPR-16