

CRUSHING

SCREENING

WASHING

CONVEYING

COMPONENTS

PLANTS

CONSTRUCTION

AFTERMARKET

CONVEYING EQUIPMENT PRODUCT HANDBOOK



TABLE OF CONTENTS

STOCKPILING CONVEYORS

- 3 TeleStacker® Conveyor
- 15 PowerStacker® Conveyor
- 21 Pinnacle® Conveyor
- 27 Radial Stacking Conveyors
- 39 Slide-Stac™ Conveyors
- 41 Tripper Conveyor

TRANSFER CONVEYORS

- 43 Trailblazer® Conveyor
- 47 Zipline® Conveyor
- 51 Overland Conveyor
- 57 In-Plant Conveyors
- 59 Stackable Conveyors
- 63 Slide-Pac™ Conveyors
- 65 Jump Conveyors
- 67 Extender Conveyor

FEED CONVEYORS

- 69 RazerTail® Truck Unloader
- 78 Stationary Drive Over Truck Unloader
- 79 Razerlink® Mobile Conveyors
- 81 Tunnel Reclaim Conveyor
- 83 Dozer Trap

COMPONENTS

- 84 Superior Exclusive Components





TELESTACKER® CONVEYOR

Defeat Material Segregation with the World's Best Selling Telescopic Conveyor

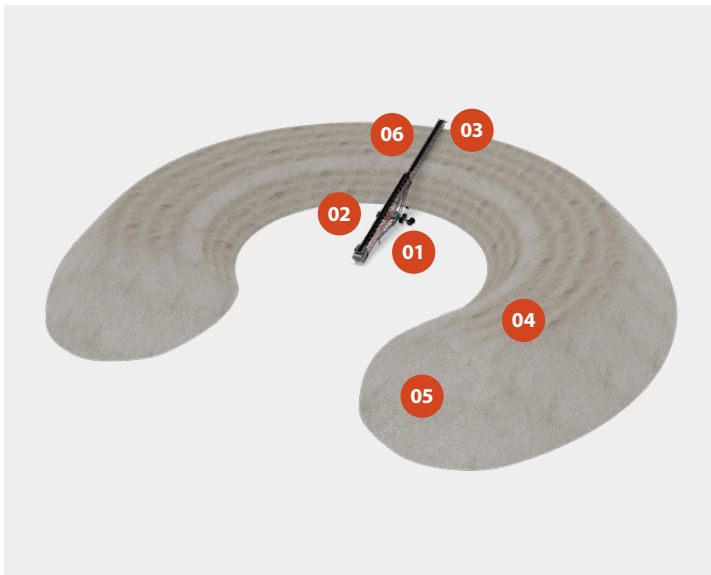

AVOID PENALTIES WITH IN-SPEC STOCKPILES

- 01/ Radial travel blends material better than conical piles.
- 02/ Variable height keeps proper mix of coarse and fine materials.
- 03/ Adjustable discharge height eliminates material overrun.
- 04/ Windrow stockpiling blends fine, medium coarse materials.
- 05/ No need to blend material with loader during reclamation.
- 06/ Programmable automation effortlessly controls motion.

Rock Face to Load Out™

 Patented Technology





	110'	130'	136'	150'	158'	170'	190'	210'
500 TPH	36"	30"		30"		36"	36"	36"
800 TPH	36"	36"	36"	36"	36"	36"	36"	36"
1,000 TPH	36"	36"	36"	36"	36"	36"	36"	36"
1,200 TPH	42"	42"		42"	42"	42"	42"	36"
1,500 TPH	42"	42"		42"	42"	42"	42"	36"
1,800 TPH				48"		48"	48"	
2,400 TPH				48"		48"	48"	
3,200 TPH				54"				
4,000 TPH				60"		60"	60"	
5,000 TPH							72"	

FEATURES



01/ CHEVRON® PULLEY

Ejects fugitive material for longer lasting pulleys and belting.

02/ SEALING SYSTEM

Maintains tight seal between belt and skirting for spillage free load zone.

03/ EXTERRA® PRIMARY CLEANER

Eliminates unwanted fugitive material on belt.

04/ ULTRASONIC PILE SENSOR

Contact free sensor is not affected by dust or debris.

05/ NAVIGATOR® RETURN TRAINER

Constantly guides and centers belt.

06/ LOAD ROLLERS

Each roller equally shares weight of stinger conveyor.

07/ STINGER SAFETY STOP

Activates in event of cable failure to maintain position of stinger.

08/ SLIDETRACK SYSTEM

Cable support system designed with no catch points and easy maintenance.

09/ FB® UNDERCARRIAGE

Provides maximum undercarriage support for safety and lateral stability.

10/ PILEPRO™ AUTOMATION

Designed in-house with clean, easy to understand interface.

11/ ROCK BOX RADIAL HOPPER

Designed for rock-on-rock wear with internal ledge.

EXCLUSIVE TO
SUPERIOR

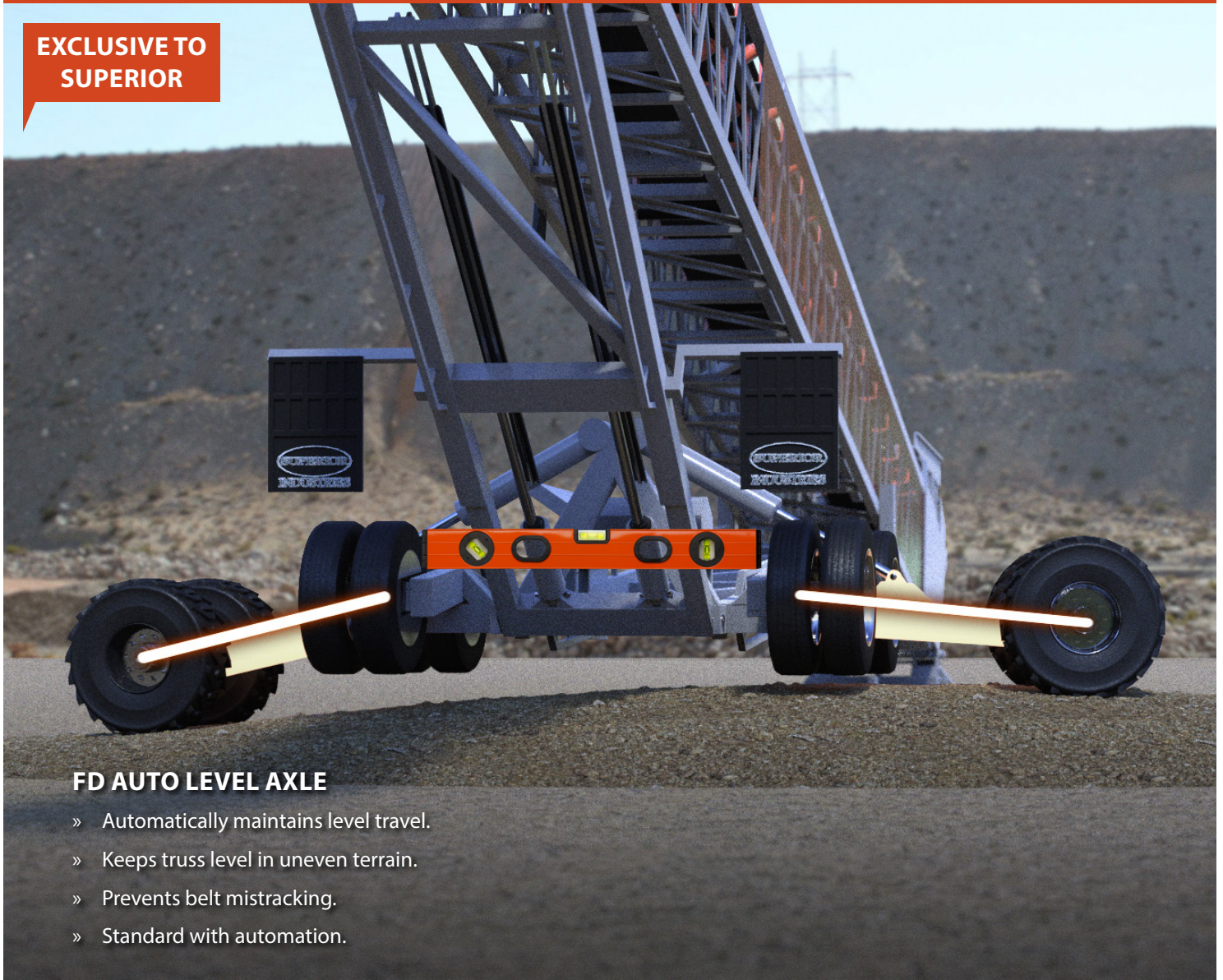

FD AUTO LEVEL AXLE

- » Automatically maintains level travel.
- » Keeps truss level in uneven terrain.
- » Prevents belt mistracking.
- » Standard with automation.



FD AXLE OPTION



FD AXLE

- » Hydraulically transfers stacker from inline to radial mode in seconds.
- » Invented by Superior in 1994 with more than 800 FD models built since.
- » Enclosed planetary drive is securely protected from damaging debris.
- » Walking beam suspension properly balances conveyor and load.

AXLE CONFIGURATIONS



XTP SWING AXLE OPTION



XTP SWING AXLE

- » Pull T-Handle to engage power travel; no chain drive.
- » Physically transfer from road to operation in minutes.
- » Concrete pad provides level runway.
- » Single link arm stays attached to machine; no handling multiple linkages.



PIT PORTABLE AXLE OPTIONS

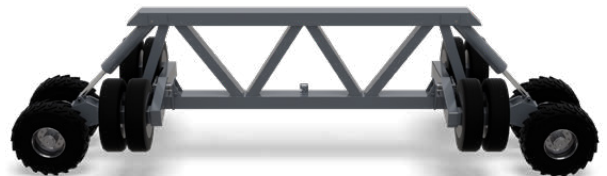

PIT PORTABLE FD AXLE



PIT PORTABLE AXLE

- » Both made from heavy duty fabricated steel.
- » Both designed for highest capacity, highest tonnage applications.
- » Both designed for towing within the quarry.



HIGHLIGHTS

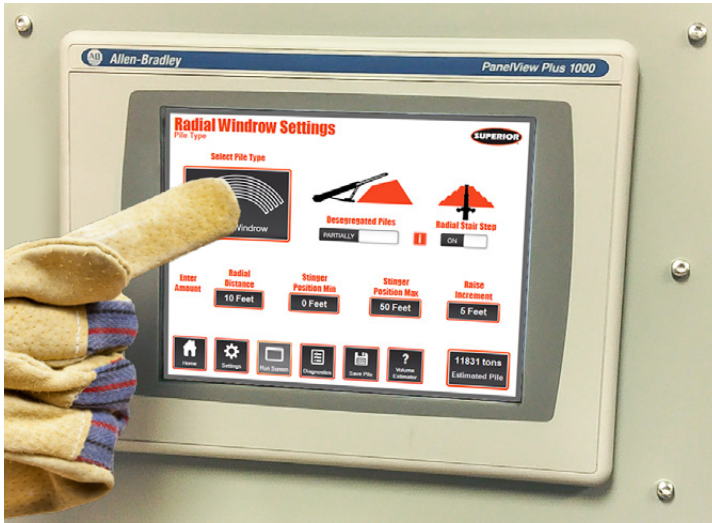

PILEPRO AUTOMATION

PILEPRO™ AUTOMATION

- » In-house engineers reduce reliance on third parties.
- » Step by step program is easy to setup and understand.
- » Diagnostics screen allows users to quickly pinpoint faults.
- » Proactive maintenance reminders signal upkeep tasks.
- » Volume estimator reports estimated pile tonnage.
- » Save settings for up to four unique pile configurations.



SLIDETRACK SYSTEM

SLIDETRACK SYSTEM

- » No areas for fugitive material to build up.
- » Proven to be more reliable in cold weather.
- » Easy to see and access for maintenance.
- » Retrofit kits for previous model TeleStacker Conveyors.



CAM ROLLERS

LOAD ROLLERS

- » Large diameter rollers support stinger conveyor.
- » Center pivot design supports weight equally on all rollers.
- » Rollers at top and bottom for additional stability.

HIGHLIGHTS



FB UNDERCARRIAGE

FB® UNDERCARRIAGE

- » Designed with more steel for rock solid bracing.
- » Fully-braced inner and outer structures.
- » Perimeter positioning of cylinders increases structural support.



STINGER SAFETY STOP

STINGER SAFETY STOP

- » Continuously monitors cable tension to stinger conveyor.
- » Immediately reacts if breakdown of cable occurs.
- » Spring loaded, mechanical device is field tested and proven.



LOW PROFILE

LOW PROFILE

- » Eliminate reliance on transfer conveyor for loading.
- » Accepts feed directly from portable crushers and screens.
- » Minimize the number of loads in portable spread.
- » Reduce space requirements with less equipment.

FEATURES



HYDRAULIC AXLE JACKS



MOBILE PIVOT BASE



FD AXLE TRACKS



MOXIE ROLLS

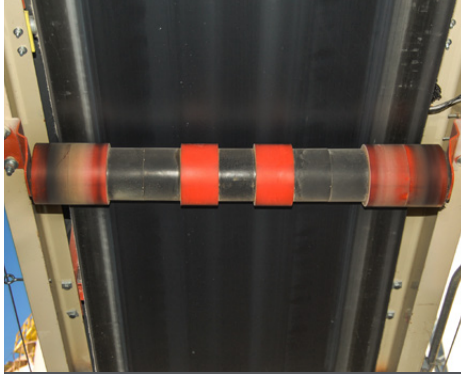

URATHON® RETURN ROLL



WALKWAYS



SPRAY BARS



COMPENSATION LINKAGE

PORTABILITY

- » 4-Wheel Drive (FD Axle)
- » Dual Power Travel (XTP Axle)
- » Hydraulic Axle Jacks (XTP Axle)
- » Tow Eye

MOBILITY

- » Tracked Mobile Pivot Base
- » Two Wheel Mobile Pivot Base
- » FD Axle Tracks

MAINTENANCE

- » Moxie® Rolls
- » Uration® Return Roll
- » Self-Aligning Idlers
- » Impact Idlers
- » Auto Greaser
- » Walkways
- » Vulcanized Splice

ENVIRONMENT

- » Mainframe Covers
- » Stinger Conveyor Cover
- » Spray Bars
- » Epoxy Paint
- » Hot Dipped Galvanized Finish
- » Cold Weather Kit

OTHER

- » Compensation Linkage
- » Belt Scale
- » Onboard Counterweight (XTP Axle)
- » Belting Upgrade
- » Wireless Remote Control
- » Dual Power Source
- » Discharge Hood

SAFETY

- » Horn
- » E-Stop
- » Belt Rip Detection
- » Belt Misalignment Detection

PHOTO GALLERY



FD AXLE IN TRANSPORT MODE



EXPERIENCE UP TO 5,000 TPH



SHIP OR BARGE LOADING



SELF-CONTAINED POWER (SEE SPEC SHEET)



HEAP LEACH MINING



BARGE UNLOADING / DREDGE CAPPING

TSFD SPECIFICATIONS

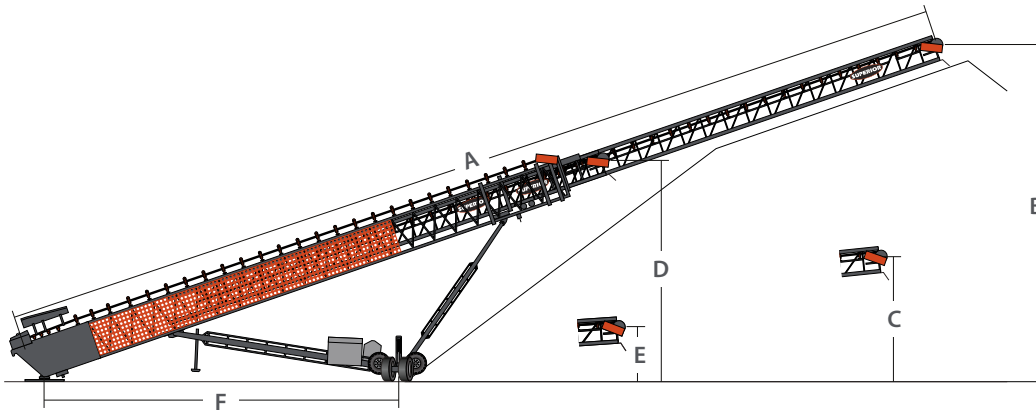

	110'		130'		136'*		140'**		150'		158'*	
	ft x in	m	ft x in	m	ft x in	m	ft x in	m	ft x in	m	ft x in	m
FD AXLE (TSFD) OPERATING SPECIFICATIONS												
(A) Conveyor Length	110'-0"	33.5	130'-0"	39.6	136'-0"	41.5	140'-0"	42.2	150'-0"	45.7	158'-0"	48.0
(B) Highest Extended Discharge Height	41'-3"	12.6	44'-3"	13.4	44'-0"	13.4	46'-3"	14.4	52'-9"	16.1	48'-10"	14.8
(C) Lowest Extended Discharge Height	18'-10"	5.7	16'-1"	4.9	18'-6"	5.6	19'-6"	5.9	19'-6"	5.9	19'-6"	5.9
(D) Highest Retracted Discharge Height	24'-9"	7.5	26'-1"	7.9	27'-1"	8.2	27'-6"	8.4	30'-10"	9.4	30'-10"	9.4
(E) Lowest Retracted Discharge Height	12'-0"	3.6	10'-4"	3.1	12'-8"	3.8	12'-1"	3.7	12'-6"	3.8	12'-4"	3.7
(F) Anchor Pivot to Center of Axle	39'-8"	12.1	49'-0"	15.0	55'-4"	16.9	51'-10"	15.8	54'-9"	16.7	70'-11"	21.6

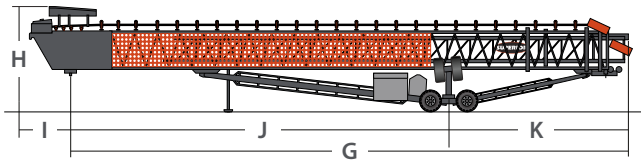

	110'		130'		136'*		140'**		150'		158'*	
	ft x in	m	ft x in	m	ft x in	m	ft x in	m	ft x in	m	ft x in	m
FD AXLE (TSFD) TRAVEL SPECIFICATIONS												
(G) Travel Length - Kingpin to Rear	60'-0"	18.2	70'-0"	21.3	80'-0"	24.4	75'-1"	22.9	80'-0"	24.4	97'-6"	29.7
(H) Travel Height	12'-5"	3.8	12'-1"	3.6	13'-0"	3.9	13'-5"	4.1	13'-10"	4.2	14'-0"	4.3
Travel Width	11'-11"	3.6	11'-11"	3.6	11'-11"	3.6	11'-9"	3.6	11'-11"	3.6	11'-9"	3.5
(I) Kingpin to End of Tow Eye	5'-10"	1.7	5'-10"	1.7	5'-10"	1.7	5'-10"	1.8	5'-11"	1.8	8'-1"	2.4
(J) Kingpin to Axle	37'-11"	11.5	47'-7"	14.5	54'-0"	16.4	51'-2"	15.6	53'-10"	16.4	70'-0"	21.3
(K) Axle to Head Pulley	22'-0"	6.7	21'-5"	6.5	25'-6"	7.7	23'-11"	7.3	26'-1"	7.9	27'-6"	8.3
FD Axle Size	FD40		FD40		FD40		FD40		FD50		FD50	

WEIGHTS												
	lbs	kg	lbs	kg	lbs	kg	lbs	kg	lbs	kg	lbs	kg
Weight at Axle - 36" Belt Width	30,500	13,830	34,800	15,785	36,000	16,329	38,000	17,236	40,000	18,144	53,200	24,131
Weight at Kingpin - 36" Belt Width	12,500	5,670	18,300	8,300	13,000	5,897	20,000	9,071	24,600	11,158	16,000	7,257

* Low profile model. ** Design optimized for container shipment.

TSSA SPECIFICATIONS

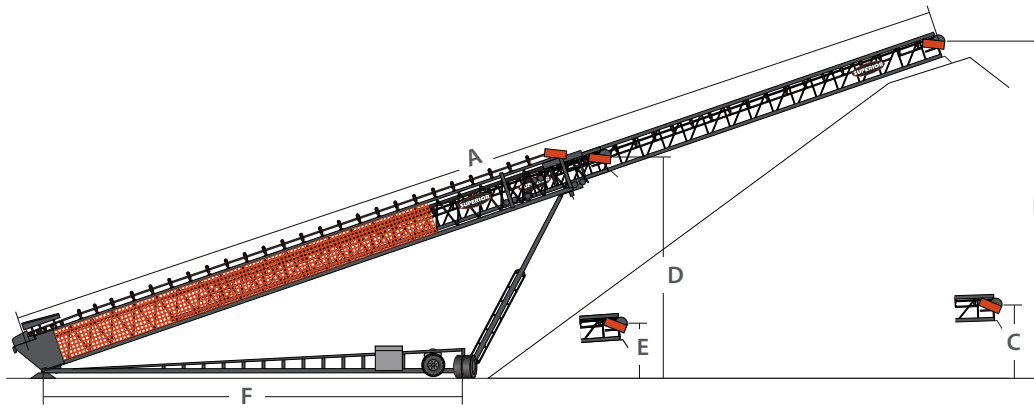

	130'		150'		170'		185'***		190'		210'*	
	ft x in	m	ft x in	m	ft x in	m	ft x in	m	ft x in	m	ft x in	m
XTP SWING AXLE (TSSA) OPERATING SPECIFICATIONS												
(A) Conveyor Length	130'-0"	39.6	150'-0"	45.7	170'-0"	51.8	185'-0"	56.2	190'-0"	57.9	210'-0"	64.0
(B) Highest Extended Discharge Height	44'-4"	13.5	52'-6"	16.0	61'-0"	18.5	64'-11"	19.8	67'-8"	20.5	71'-8"	21.8
(C) Lowest Extended Discharge Height	14'-2"	4.3	15'-10"	4.8	14'-11"	4.5	15'-9"	4.8	16'-1"	5.0	16'-11"	5.2
(D) Highest Retracted Discharge Height	26'-5"	8.0	31'-3"	9.5	38'-6"	11.0	38'-4"	11.7	38'-7"	11.0	41'-2"	12.5
(E) Lowest Retracted Discharge Height	9'-7"	2.9	10'-9"	3.2	10'-8"	3.2	10'-10"	3.3	10'-9"	3.2	11'-4"	3.5
(F) Anchor Pivot to Center of Axle	48'-6"	14.5	56'-4"	17.0	73'-10"	22.5	73'-5"	22.4	73'-10"	22.5	81'-11"	25.0

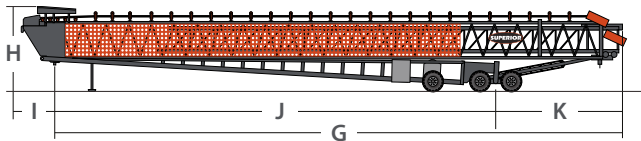

	130'		150'		170'		185'***		190'		210'*	
	ft x in	m	ft x in	m	ft x in	m	ft x in	m	ft x in	m	ft x in	m
XTP SWING AXLE (TSSA) TRAVEL SPECIFICATIONS												
(G) Travel Length - Kingpin to Rear	69'-9"	21.2	80'-0"	24.3	100'-0"	30.5	99'-8"	30.4	100'-1"	30.5	113'-1"	34.5
(H) Travel Height	12'-7"	3.8	13'-9"	4.2	13'-9"	4.2	15'-9"	4.8	14'-0"	4.2	14'-8"	4.5
Travel Width	11'-11"	3.6	11'-11"	3.6	11'-11"	3.6	12'-1"	3.7	11'-11"	3.6	11'-11"	3.6
(I) Kingpin to End of Tow Eye	6'-6"	2.0	6'-6"	2.0	6'-6"	2.0	5'-10"	1.8	6'-6"	2.0	6'-6"	2.0
(J) Kingpin to Axle	52'-3"	15.9	59'-9"	18.2	77'-3"	23.5	77'-1"	23.5	77'-3"	23.5	85'-6"*	26.0*
(K) Axle to Head Pulley	17'-5"	5.3	20'-4"	6.1	22'-10"	6.9	22'-7"	6.9	22'-10"	6.9	27'-7"*	8.4*
WEIGHTS												
	lbs	kg	lbs	kg	lbs	kg	lbs	kg	lbs	kg	lbs	kg
Weight at Axle - 36" Belt Width	34,400	15,605	38,000	17,235	46,000	20,865	49,000	22,226	47,000	21,318	66,700*	30,255*
Weight at Kingpin - 36" Belt Width	19,500	8,845	18,550	8,414	20,865	9,464	26,000	11,793	22,500	10,205	35,700*	16,194*

* Contact Superior Industries for additional shipping information. ** Design optimized for container shipment.

STOCKPILE SPECIFICATIONS

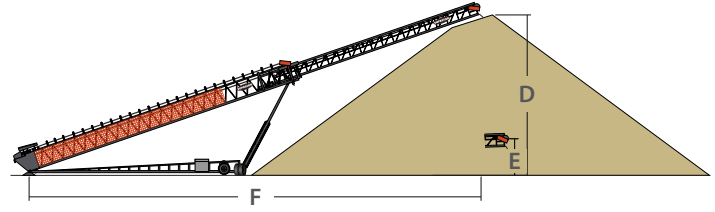
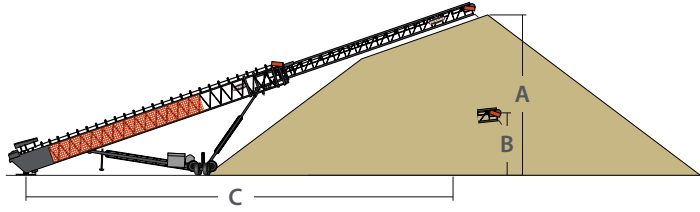

TSFD STOCKPILE

TSSA STOCKPILE

	110'		130'		136'		140'		150'		158'	
	ft x in	m	ft x in	m	ft x in	m	ft x in	m	ft x in	m	ft x in	m
STOCKPILE DIMENSIONS (TSFD)												
(A) Maximum Pile Height	39'-2"	11.9	43'-0"	13.1	43'-2"	13.1	45'-3"	13.8	50'-0"	15.2	47'-3"	14.4
(B) Lowered Stockpile Height	15'-6"	4.7	15'-10"	4.8	14'-9"	4.5	17'-4"	5.3	16'-7"	5.0	18'-10"	5.7
(C) Anchor Pivot to Center of Pile	101'-1"	30.8	116'-11"	35.6	120'-2"	36.6	129'-11"	39.6	132'-6"	40.3	146'-4"	44.6
* Low Profile Model												
	130'		150'		170'		185'		190'		210'	
	ft x in	m	ft x in	m	ft x in	m	ft x in	m	ft x in	m	ft x in	m
STOCKPILE DIMENSIONS (TSSA)												
(D) Maximum Pile Height	44'-5"	13.5	50'-0"	15.2	58'-3"	17.7	63'-3"	19.3	66'-1"	20.1	69'-2"	21.1
(E) Lowered Stockpile Height	11'-5"	3.4	12'-10"	3.9	11'-11"	3.6	13'-9"	4.2	14'-3"	4.3	16'-11"	5.2
(F) Anchor Pivot to Center of Pile	116'-2"	35.4	134'-5"	40.9	157'-6"	48.0	176'-2"	53.7	171'-7"	52.2	189'-3"	57.6

Conveyor Length	Stockpile Height		Conical		90°		180°		270°		
	ft	ft x in	m	tons	metric tons	tons	metric tons	tons	metric tons	tons	metric tons
MAXIMUM STOCKPILE CAPACITIES (MANUAL PILES)*											
110 TSFD	39'-0"	11.8	6,600	6,000	26,600	24,100	46,500	42,200	66,500	60,300	
130 TSFD	42'-0"	12.8	8,400	7,600	36,800	33,400	65,200	59,100	93,600	84,900	
130 TSSA	45'-6"	13.8	9,000	8,200	37,400	34,000	65,800	59,600	94,200	85,500	
136 TSFD-LP	41'-6"	12.6	9,300	8,400	40,600	36,800	71,900	65,200	103,200	93,600	
140 TSFD	45'-3"	13.8	10,315	9,360	42,330	38,400	74,340	67,440	106,440	96,560	
150 TSFD	50'-0"	15.2	12,600	11,400	55,300	50,200	98,100	89,000	140,800	127,700	
150 TSSA	50'-0"	15.2	12,400	11,200	54,100	49,000	95,900	87,000	137,700	124,900	
158 TSFD-LP	47'-0"	14.3	13,100	11,900	55,200	50,100	97,500	88,400	139,700	126,800	
170 TSSA	58'-0"	17.6	17,500	15,900	75,800	68,800	134,000	121,600	192,300	174,500	
185 TSSA	63'-3"	19.3	26,630	24,160	109,000	98,880	191,360	173,600	273,725	248,320	
190 TSSA	66'-0"	20.1	25,300	23,000	111,100	100,800	196,800	178,500	282,600	256,400	
210 TSPP	70'-3"	21.4	36,825	28,154	156,050	119,308	275,275	210,462	395,500	302,381	

* Assumptions based on material which has a 37° angle of repose and 100 PCF (1.6 t/m³) material density.



POWERSTACKER® CONVEYOR

Variable Height Portable Stacker with High Speed Road to Radial Shifting Axles



FD AXLE ENGAGES RADIAL TIRES IN SECONDS



POWER FOLD HYDRAULICALLY UNFOLDS CONVEYOR

Rock Face to Load Out™

 Patented Technology



FEATURES



01/ TOW EYE

Adjustable pintle style hitch provides the most secure coupling.

02/ RADIAL RECEIVING HOPPER

Bolt on design includes adjustable flashing in gathering trough.

03/ CHEVRON® PULLEY

Ejects fugitive material for longer lasting pulleys and belting.

04/ SUPERIOR IDLERS

Trusted seal design provides shields bearing from fugitive material.

05/ V-PLOW

Shields tail pulley from onslaught of damaging fugitive material.

06/ HYDRAULIC POWERFOLD

Inverted design protects cylinder rods from debris during operation.

07/ FD AXLE

Hydraulically transfers stacker from inline to radial mode in seconds.

08/ ENCLOSED POWER TRAVEL

Enclosed planetary drive protected from debris.

09/ BELT RETAINER

Protects conveyor and integrity of belting during folding/unfolding.

10/ HYDRAULIC CONTROL CENTER

Quickly raise, lower, fold and unfold conveyor.

FEATURES



01/ TOW EYE

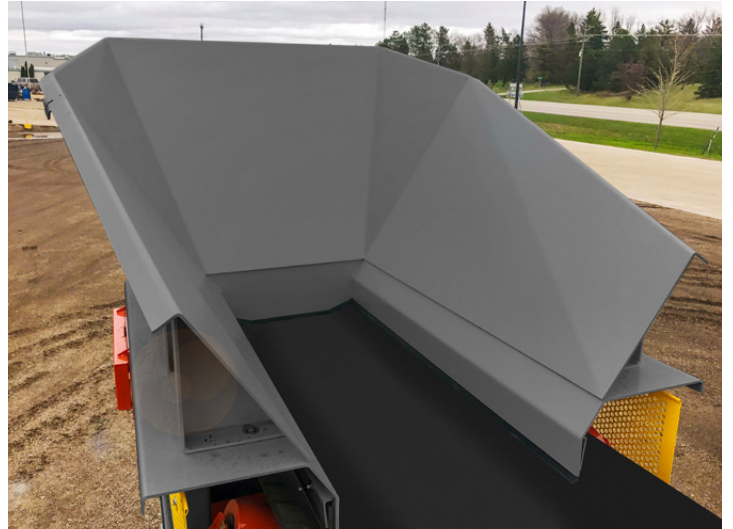

02/ RADIAL RECEIVING HOPPER



05/ V-PLOW



07/ FD AXLE ASSEMBLY



09/ BELT RETAINER



10/ HYDRAULIC CONTROL CENTER

FEATURES



FD AXLE



HYDRAULIC POWERFOLD



ONBOARD POWER



EXTERRA SFL DUAL



BELT SCALE



HOT DIPPED GALVANIZE FINISH

PORTABILITY

- » 4-Wheel Drive (FD Axle)
- » Tow Eye

OPERATION

- » Hydraulic Powerfold
- » Hydraulic Raise/Lower

MOBILITY

- » Onboard Power
- » All Wheel Drive

MAINTENANCE

- » Moxie® Rolls
- » Urathon® Return Rolls
- » Sealing System
- » Impacts Rolls
- » Impact Bed
- » Exterra® SFL Dual Belt Cleaner
- » Auto Greaser

ENVIRONMENT

- » Belt Covers
- » Epoxy Paint
- » Hot Dipped Galvanized Finish

OTHER

- » Belt Scale
- » Sonicscout™ Material Sensor
- » Anchor Pivot Plate
- » Class II Reducer
- » Landing Gear
- » Vulcanized Belt Splice

SPECIFICATIONS

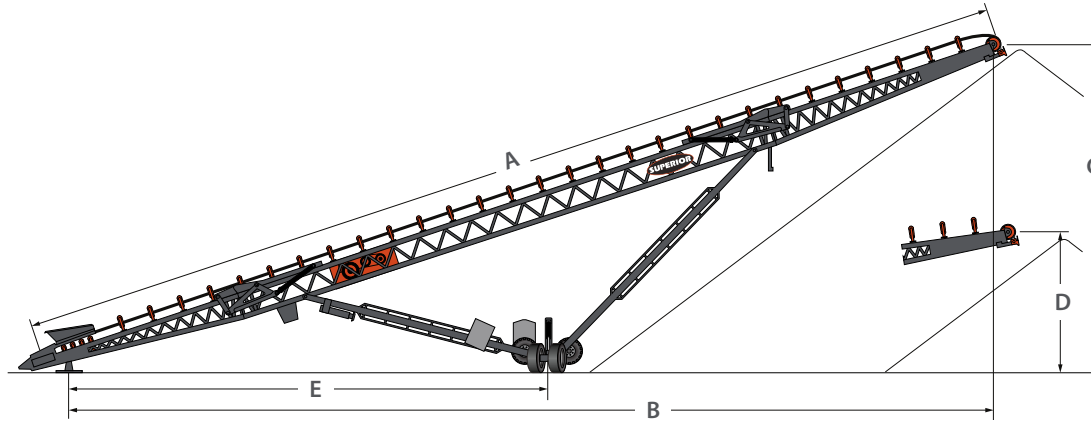

	95'		110'		125'		150'	
	ft x in	m	ft x in	m	ft x in	m	ft x in	m
OPERATING SPECIFICATIONS								
(A) Conveyor Length	95'-0"	29.0	110'-0"	33.5	125'-0"	38.1	150'-0"	45.7
(B) Conveyor Ground Length	88'-4"	26.9	102'-0"	31.1	118'-11"	36.2	140'-4"	42.8
(C) Raised Height to Center of Pulley	32'-3"	9.8	36'-4"	11.1	41'-4"	12.6	48'-0"	14.6
(D) Lowered Height to Center of Pulley	13'-8"	4.2	17'-2"	5.2	17'-7"	5.4	15'-2"	4.6
(E) Anchor Pivot to Center of Axle	47'-7"	14.5	56'-3"	17.2	60'-2"	18.3	79'-6"	24.1

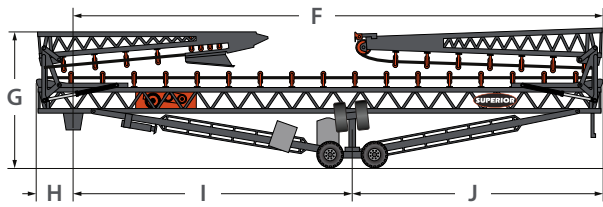

	95'		110'		125'		150'	
	ft x in	m	ft x in	m	ft x in	m	ft x in	m
TRAVEL SPECIFICATIONS								
(F) Travel Length - Kingpin to Rear	73'-7"	22.4	54'-10"	16.7	64'-9"	19.7	74'-9"	22.7
(G) Travel Height	13'-6"	4.2	14'-1"	4.3	14'-0"	4.3	13'-11"	4.2
Travel Width	11'-7"	3.5	11'-8"	3.5	11'-11"	3.6	11'-11"	3.6
(H) Kingpin to End of Tow Eye	5'-1"	1.6	5'-11"	1.8	6'-0"	1.8	5'-11"	1.8
(I) Kingpin to Axle	50'-11"	15.5	29'-2"	8.9	33'-6"	10.2	49'-6"	15.1
(J) Axle to Head Pulley	22'-8"	6.9	25'-8"	7.9	31'-3"	9.5	25'-3"	7.7
FD Axle Size	FD15	FD15	FD20	FD20	FD40	FD40	FD50	FD50
WEIGHTS								
	lbs	kg	lbs	kg	lbs	kg	lbs	kg
Weight at Axle - 36" Belt Width	17,750	8,051	19,940	9,044	33,000	14,969	34,200	15,513
Weight at Kingpin - 36" Belt Width	4,000	1,814	3,060	1,388	3,500	1,588	10,200	4,627

STOCKPILE SPECIFICATIONS

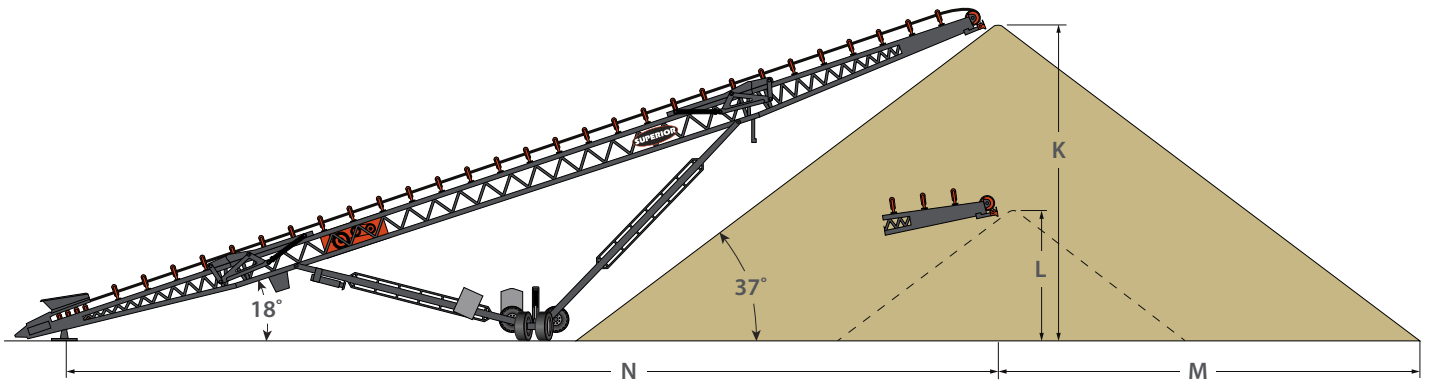

	95'		110'		125'		150'	
	ft x in	m	ft x in	m	ft x in	m	ft x in	m
STOCKPILE DIMENSIONS								
(K) Raised Stockpile Height	32'-0"	9.8	37'-0"	11.3	42'-0"	12.8	50'-0"	15.2
(L) Lowered Stockpile Height	12'-4"	3.8	16'-2"	4.9	17'-3"	5.3	13'-8"	4.2
(M) Radius of Pile	41'-1"	12.5	47'-2"	14.4	54'-6"	16.6	61'-8"	18.8
(N) Anchor Pivot to Center of Pile	91'-0"	27.7	104'-6"	31.9	118'-6"	36.2	144'-0"	43.9

Conveyor Length	Stockpile Height		Conical		90°		180°		270°	
	ft x in	m	tons	metric tons	tons	metric tons	tons	metric tons	tons	metric tons
MAXIMUM STOCKPILE CAPACITIES (MANUAL PILES)*										
95'	32'-0"	9.8	3,100	2,800	13,000	11,800	22,800	20,700	32,700	29,700
110'	37'-0"	11.3	4,700	4,300	19,600	17,800	34,500	31,300	49,400	44,800
125'	42'-0"	12.8	6,700	6,100	28,100	25,500	49,600	45,000	71,000	64,400
150'	49'-0"	14.9	11,100	10,100	47,300	42,900	83,500	75,700	119,700	108,600

* Assumptions based on material which has a 37° angle of repose and 100 PCF (1.6 t/m³) material density.



PINNACLE[®] CONVEYOR

Setback Axle Allows Stacking Angle of 22° For Higher Capacity Stockpiles



BUILD TALLER STOCKPILES



36" x 125' PINNACLE CONVEYOR

FEATURES



01/ TOW EYE

Adjustable pintle style hitch provides the most secure coupling.

02/ RADIAL RECEIVING HOPPER

Bolt on design includes adjustable flashing in gathering trough.

03/ CHEVRON® PULLEY

Ejects fugitive material for longer lasting pulleys and belting.

04/ SUPERIOR IDLERS

Trusted seal design provides shields bearing from fugitive material.

05/ V-PLOW

Shields tail pulley and drive from onslaught of damaging fugitive material.

06/ SETBACK AXLE

Creates a 22° incline for higher volume piles without burying axle.

07/ FD AXLE*

Hydraulically transfers stacker from inline to radial mode in seconds.

08/ ENCLOSED POWER TRAVEL

Enclosed planetary drive protected from debris.

09/ HYDRAULIC POWERFOLD

Inverted design protects cylinder rods from debris during operation.

AXLE CONFIGURATIONS

STYLE OF AXLE

Model	Fixed Width Portable	Telescoping Tube	XTP Axle	Fixed Width Pit Portable	FD Axle
30" x 80'	■	□	□	□	■
36" x 80'	□	■	□	□	■
30" x 100'	□	■	■	■	■
36" x 100'	□	■	■	■	■
36" x 125'	□	■	■	■	■
42" x 125'	□	■	■	■	■

■ Standard ■ Option □ Not Available

FEATURES

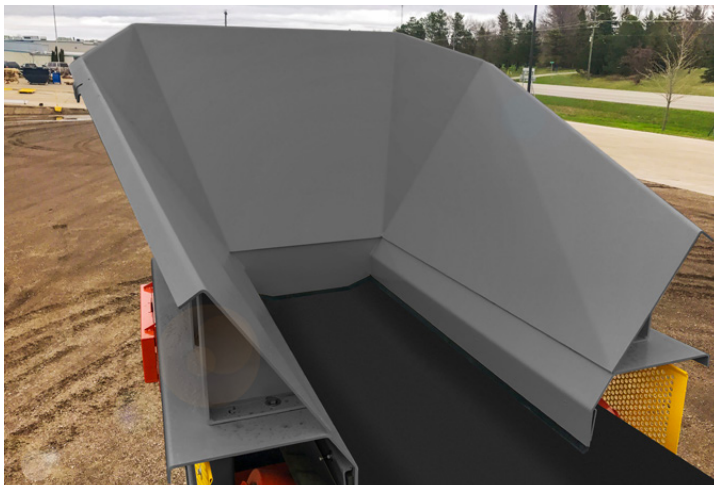

02/ RADIAL RECEIVING HOPPER



03/ CHEVRON PULLEY



05/ V-PLOW



06/ SETBACK AXLE

Rock Face to Load Out™

PINNACLE® CONVEYOR

FEATURES



XTP AXLE

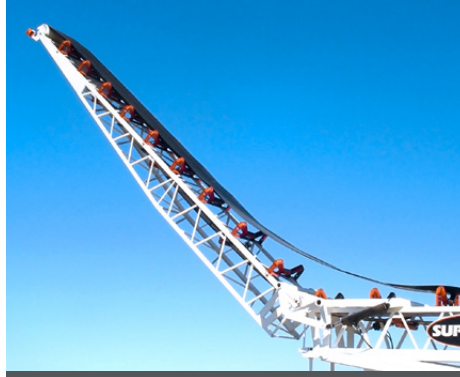

HYDRAULIC POWERFOLD

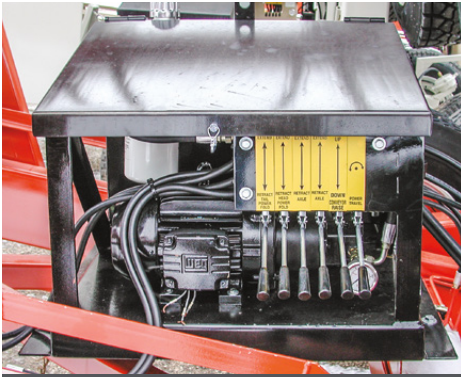

HYDRAULIC RAISE/LOWER



SEALING SYSTEM



MODULAR FEED HOPPER



BELT SCALE



SONICSCOUT SENSOR

PORTABILITY

- » 4-Wheel Drive (FD Axle)
- » Dual Power Travel (XTP Axle)
- » Hydraulic Axle Jacks (XTP Axle)
- » Tow Eye

OPERATION

- » Hydraulic Powerfold
- » Hydraulic Raise/Lower

MAINTENANCE

- » Moxie® Rolls
- » Urathon® Return Rolls
- » Sealing System
- » Impacts Rolls
- » Impact Bed
- » Exterra® SFL Dual Belt Cleaner
- » Receiving Hopper
- » Auto Greaser

ENVIRONMENT

- » Belt Covers
- » Epoxy Paint
- » Hot Dipped Galvanized Finish

OTHER

- » Belt Scale
- » SonicScout™ Material Sensor
- » Anchor Pivot Plate
- » Class II Reducer
- » Vulcanized Belt Splice
- » Modular Feed Hopper

SPECIFICATIONS

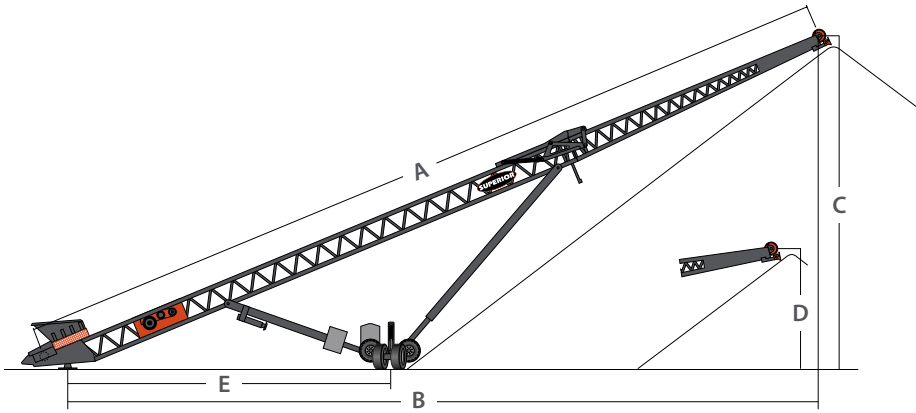

	80'		100'		125'	
	ft x in	m	ft x in	m	ft x in	m
OPERATING SPECIFICATIONS						
(A) Conveyor Length	80'-0"	24.4	100'-0"	30.5	125'-0"	38.1
(B) Conveyor Ground Length	72'-3"	22.0	91'-8"	27.9	116'-4"	35.4
(C) Raised Height to Center of Pulley	32'-5"	9.9	39'-4"	12.0	50'-8"	15.4
(D) Lowered Height to Center of Pulley	18'-1"	5.5	20'-1"	6.1	18'-2"	5.4
(E) Anchor Pivot to Center of Axle	32'-2"	9.8	39'-4"	11.9	46'-5"	14.2

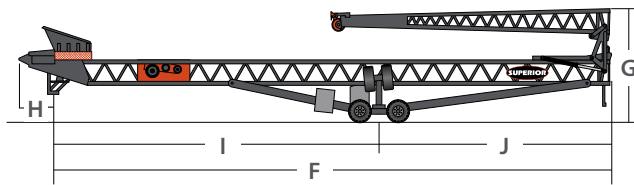

	80'		100'		125'	
	ft x in	m	ft x in	m	ft x in	m
TRAVEL SPECIFICATIONS						
(F) Travel Length - Kingpin to Rear	53'-7"	16.4	68'-8"	21.0	84'-2"	25.7
(G) Travel Height	13'-5"	4.0	13'-2"	4.0	13'-11"	4.2
Travel Width	11'-7"	3.5	12'-2"	3.7	11'-6"	3.5
(H) Kingpin to End of Tow Eye	5'-1"	1.5	5'-7"	1.7	5'-6"	1.7
(I) Kingpin to Axle	34'-7"	10.6	39'-7"	12.1	49'-4"	15.1
(J) Axle to Head Pulley	19'-0"	5.8	29'-1"	8.9	34'-10"	10.6
FD Axle Size (If Equipped)	FD15	FD15	FD20	FD20	FD40	FD40
WEIGHTS						
	lbs	kg	lbs	kg	lbs	kg
Weight at Axle - 36" Belt Width	20,000	9,072	27,250	12,360	39,500	17,917
Weight at Kingpin - 36" Belt Width	6,500	2,948	6,300	2,858	9,500	4,309

STOCKPILE SPECIFICATIONS

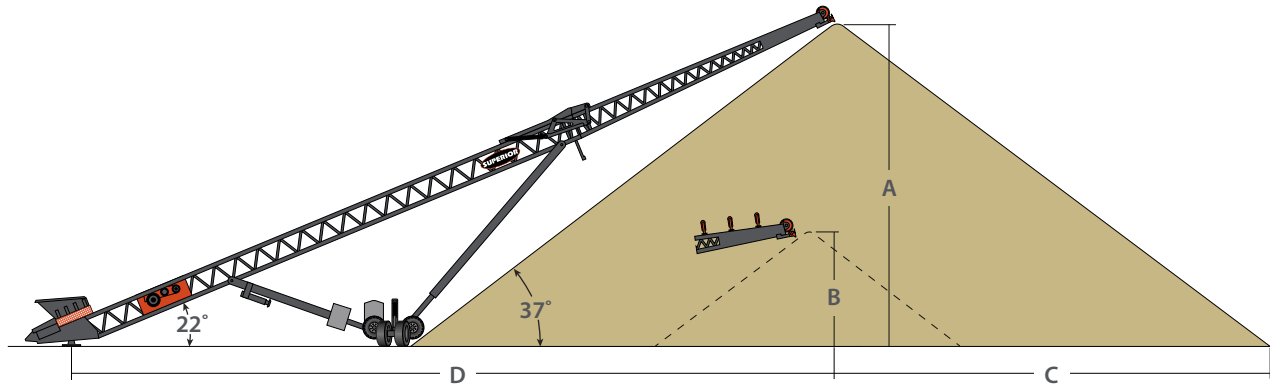

	80'		100'		125'	
	ft x in	m	ft x in	m	ft x in	m
STOCKPILE SPECIFICATIONS						
(A) Raised Stockpile Height	33'-0"	10.1	40'-0"	12.2	50'-0"	15.2
(B) Lowered Stockpile Height	18'-1"	5.5	20'-1"	6.1	18'-2"	5.5
(C) Radius of Pile	42'-2"	12.9	51'-7"	15.8	66'-5"	20.3
(D) Anchor Pivot to Center of Pile	74'-6"	22.7	93'-0"	28.4	114'-7"	35.0

Conveyor Length	Stockpile Height		Conical		90°		180°		270°		
	ft	ft x in	m	tons	metric tons	tons	metric tons	tons	metric tons	tons	metric tons
MAXIMUM STOCKPILE CAPACITIES (MANUAL PILES)*											
80'	33'-0"	10.1	3,300	3,000	11,700	10,600	20,100	18,200	28,500	25,900	
100'	40'-0"	12.2	6,100	5,500	21,900	20,000	37,700	34,200	53,600	48,600	
125'	50'-0"	15.2	11,400	10,300	41,400	37,600	71,400	64,800	101,400	92,000	

* Assumptions based on material which has a 37° angle of repose and 100 PCF (1.6 t/m³) material density.



RADIAL STACKING CONVEYORS

Hundreds of Configurations, Which is Right for You?



CUSTOM LENGTHS UP TO 200' (60M)

FEATURES

- » Four dozen pre-engineered base models for faster lead times
- » Dozens of options to configure stacker to your application
- » Willingness to explore, invent and test brand new options
- » Leading innovator of portability for swift transitions from road to work

BASE MODEL SPECIFICATIONS

Conveyor Length		Belt Width		Truss Depth		Capacity*		Belt Speed	
ft	m	inch	mm	inch	mm	STPH	MTPH	FPM	MPM
40'	12.2	24"	610	24"	610	300	275	350	105
		30"	762	24"	610	500	450	350	105
		36"	914	24"	610	750	680	400	120
		42"	1,067	24"	610	1,200	1,100	400	120
50'	15.2	24"	610	24"	610	300	275	350	105
		30"	762	24"	610	500	450	350	105
		36"	914	24"	610	750	680	400	120
		42"	1,067	24"	610	1,200	1,100	400	120
60'	18.3	24"	610	24"	610	300	275	350	105
		30"	762	24"	610	500	450	350	105
		36"	914	24"	610	750	680	400	120
		42"	1,067	24"	610	1,200	1,100	400	120
70'	21.3	24"	610	24"	610	300	275	350	105
		30"	762	24"	610	500	450	350	105
		36"	914	24"	610	750	680	400	120
		42"	1,067	30"	762	1,200	1,100	400	120
80'	24.4	24"	610	30"	762	300	275	350	105
		30"	762	30"	762	500	450	350	105
		36"	914	30"	762	750	680	400	120
		42"	1,067	30"	762	1,200	1,100	400	120
90'	27.4	24"	610	30"	762	300	275	350	105
		30"	762	30"	762	500	450	350	105
		36"	914	30"	762	750	680	400	120
		42"	1,067	36"	914	1,200	1,100	400	120
95'	29.0	24"	610	30"	762	300	275	350	105
		30"	762	30"	762	500	450	400	120
		36"	914	30"	762	750	680	400	120
		42"	1,067	36"	914	1,200	1,100	400	120
100'	30.5	24"	610	30"	762	300	275	350	105
		30"	762	30"	762	500	450	400	120
		36"	914	30"	762	750	680	400	120
		42"	1,067	36"	914	1,200	1,100	400	120
110'	33.5	24"	610	36"	914	300	275	350	105
		30"	762	36"	914	500	450	400	120
		36"	914	36"	914	750	680	400	120
		42"	1,067	36"	914	1,200	1,100	400	120
125'	38.1	24"	610	36"	914	300	275	350	105
		30"	762	36"	914	500	450	350	105
		36"	914	36"	914	750	680	400	120
		42"	1,067	36"	914	1,200	1,100	350	105
150'	45.7	24"	610	36"	914	300	275	350	105
		30"	762	42"	1,067	500	450	350	105
		36"	914	42"	1,067	750	680	400	120
		42"	1,067	42"	1,067	1,200	1,100	400	120

All base models include:

- » Belt widths of 24", 30", 36" and 42" (610, 762, 914 and 1,067mm).
- » Production capacities of 300 - 1,200 STPH (375 - 1,100 MTPH) subject to material density and size.

*Capacity subject to change based material density and lump size.

BASE MODEL SPECIFICATIONS

DRIVE CONFIGURATION

Head end drives include a lagged CEMA drum pulley. Single wrap drives include a lagged CEMA drum pulley and CEMA Chevron® snub pulley at the tail. Upgrades to mine or super duty pulleys are available.

	Belt Width	40'	50'	60'	70'	80'	90'	95'	100'	110'	125'	150'
Class I, Head End (1)	24"	■	■	■	■	■	■	■	■	■	■	□
	30"	■	■	■	■	■	■	■	■	■	□	□
	36"	■	■	■	■	■	■	■	■	□	□	□
	42"	■	■	■	□	□	□	□	□	□	□	□
Class I, Single Wrap (2)	24"	□	□	□	□	□	□	□	□	□	□	■
	30"	□	□	□	□	□	□	□	□	□	■	■
	36"	□	□	□	□	□	□	□	□	■	■	■
	42"	□	□	□	■	■	■	■	■	■	■	■

■ Standard □ Available Upon Request

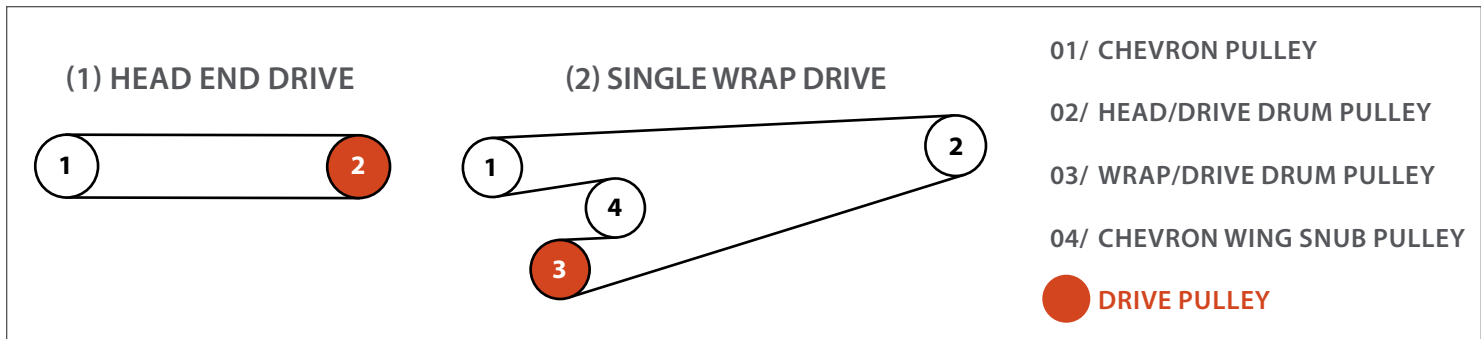

- 01/ CHEVRON PULLEY
 - 02/ HEAD/DRIVE DRUM PULLEY
 - 03/ WRAP/DRIVE DRUM PULLEY
 - 04/ CHEVRON WING SNUB PULLEY
- DRIVE PULLEY

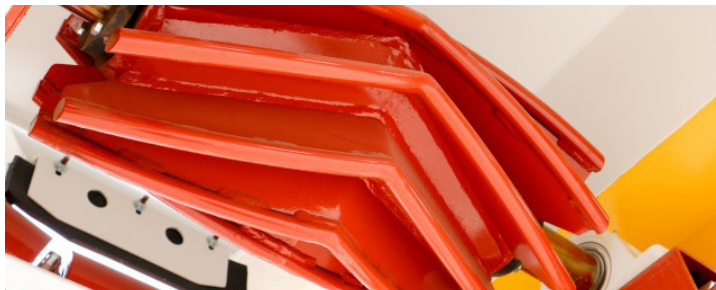

CHEVRON PULLEY

V-shaped wings reject fugitive material at tail, which extends life of belts.



DRUM PULLEY

Superior designed and built for head section. Upgrade lagging or model.

BELT TAKE-UP

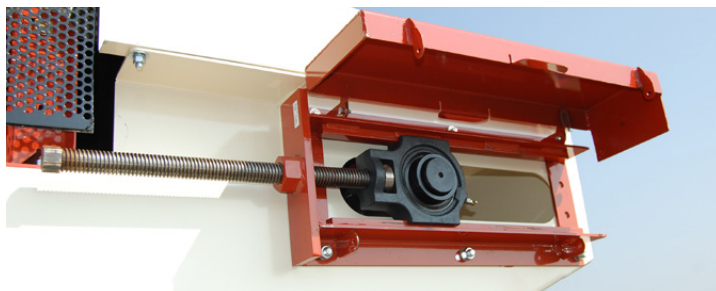

MECHANICAL SCREW

Designed and built with ACME rods and powder coat frame.





GRAVITY

Automatically adjust for belt stretch on longer conveyors.

CONVEYOR CONFIGURATION GUIDE

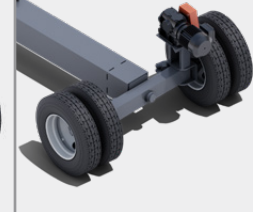
AXLE CONFIGURATIONS

Conveyor Length	Belt Width(s)	Fixed Width Portable	Telescoping Tube	Fixed Width Pit Portable	FD Axle
					
		Lift tire(s) from ground, pull pin and manually swivel tire to inline road or radial travel position	Telescoping tube retracts for legal road width or extends to create stability for longer stackers. Utilizes same swivel function as fixed width portable axle	More robust single beam axle designed for units that don't require road portability. Utilizes same swivel function to rotate tires for transport within the quarry or mine	Radial travel tires hydraulically shift into position for fastest transition time from inline road to radial travel modes. For producers traveling frequently from site to site
40'	24", 30", 36", 42"	■	□	□	□
50'	24", 30", 36", 42"	■	□	□	□
60'	24", 30", 36"	■	□	□	□
60'	42"	□	■	□	□
70'	24", 30"	■	□	□	□
70'	36", 42"	□	■	□	□
80'	24", 30", 36", 42"	□	■	□	FD15
90'	24", 30", 36", 42"	□	■	□	FD15
95'	24", 30", 36", 42"	□	■	□	FD15
100'	24", 30", 36"	□	■	□	FD20
100'	42"	□	■	■	FD20
110'	24", 30", 36", 42"	□	■	■	FD20
125'	24", 30", 36", 42"	□	■	■	FD40
150'	24", 30", 36", 42"	□	■	■	FD40

■ Standard
 ■ Option
 Available Upon Request

LANDING GEAR



LANDING GEAR

Manual pin adjustment, manual crank or hydraulic raise and lower.

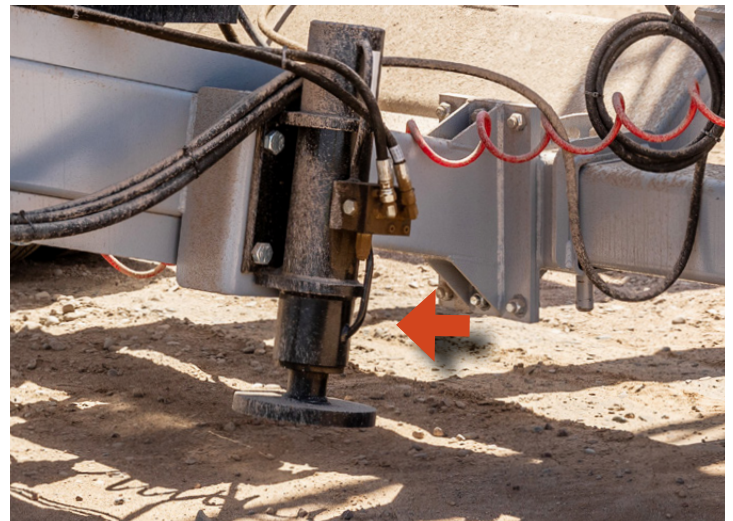

AXLE JACKS

Hydraulically raise axle to relieve wheel pressure and swivel into radial position.

CONVEYOR CONFIGURATION GUIDE

BELT SPLICES

A manual top fold requires extra equipment and time while a hydraulic fold operation is a press of a button on the control panel.

	40'	50'	60'	70'	80'	90'	95'	100'	110'	125'	150'
Bolt Together Splice	<input type="checkbox"/>	<input type="checkbox"/>	<input type="checkbox"/>	<input type="checkbox"/>	<input checked="" type="checkbox"/>	<input checked="" type="checkbox"/>	<input checked="" type="checkbox"/>	<input checked="" type="checkbox"/>	<input checked="" type="checkbox"/>	<input checked="" type="checkbox"/>	<input checked="" type="checkbox"/>
Manual Top Fold (1)	<input type="checkbox"/>	<input type="checkbox"/>	<input type="checkbox"/>	<input type="checkbox"/>	<input checked="" type="checkbox"/>	<input checked="" type="checkbox"/>	<input checked="" type="checkbox"/>	<input checked="" type="checkbox"/>	<input checked="" type="checkbox"/>	<input checked="" type="checkbox"/>	<input checked="" type="checkbox"/>
Hydraulic Top Power Fold (2)	<input type="checkbox"/>	<input type="checkbox"/>	<input type="checkbox"/>	<input type="checkbox"/>	<input checked="" type="checkbox"/>	<input checked="" type="checkbox"/>	<input checked="" type="checkbox"/>	<input checked="" type="checkbox"/>	<input checked="" type="checkbox"/>	<input checked="" type="checkbox"/>	<input checked="" type="checkbox"/>

Standard
 Option
 Available Upon Request



MANUAL TOP FOLD



HYDRAULIC POWER FOLD

Patented inverted hydraulic cylinder protects the rods from dust and debris.

CONVEYOR RAISE



MANUAL PIN (BASE CONFIGURATION)

Manual raise and lowering requires additional equipment and time.



HYDRAULIC OPERATION

Hydraulic operation is a push of a button on the control panel.

CONVEYOR CONFIGURATION GUIDE

CONVEYOR BELT

There are many belting upgrades available beyond the most popular shown below.



3-PLY 330# 3/16" x 1/16"

Tough polyester/nylon carcass and abrasion resistance.



CHEVRON CLEATS

Popular for incline applications in aggregate and recycling.

BELT TRACKING



NAVIGATOR® RETURN TRAINER

Provides continuous belt alignment with no damaging side contact.



TROUGHING SELF-ALIGNING IDLERS

Misaligned belts contact side roller, idler pivots and centers belt.

EXTERRA® BELT SCRAPERS



PRIMARY CLEANER

Standard primary blade has up to 40% more urethane than competitors.



SECONDARY CLEANER

Segmented chunks with tungsten carbide tips for long life.



SFL DUAL CLEANER

Primary and secondary blade on one pole. Maintains proper tension for life of blade.

CONVEYOR CONFIGURATION GUIDE

RECEIVING HOPPERS



GATHERING TROUGH (BASE)

Small target with skirting between belting and load zone.



ROCK BOX

Ledges catch material (rock on rock) and provide larger target for conveyor feed.

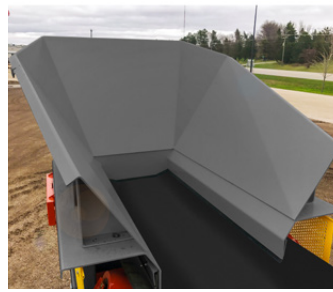

RADIAL RECEIVING

Sloped sides (rock on steel) provide larger target for conveyors to feed into load zone.



MODULAR FEED

Much larger sloped sides with wing extensions to allow feed from a bucket or clam.

LOAD ZONE



SEALING SYSTEM

Maintains tight seal between belting and skirting to eliminate spillage.



IMPACT BED

Energy absorbing bars protect belt from falling material. For high-capacity applications.



IMPACT IDLERS

Act as a cushion to prevent belt damage from falling material.



IMPACT CRADLE

Energy absorbing urethane segments protect belt from falling material.

IDLERS



MOXIE® ROLLS

HDPE sheds sticky material to prevent buildup on rolls for better belt tracking.



URATHON® RETURN ROLLS

Urethane sheds sticky material to prevent buildup on rolls for better belt tracking.



APPLICATION-SPECIFIC IDLER SEALS

Application-specific idler seals for better bearing protection in wet or dusty conditions.

CONVEYOR CONFIGURATION GUIDE

FRAME FINISHING



GALVANIZED FINISH

Hot dipped zinc coating protects steel from air contamination and rust.



CLASS 2 OR 3 PAINT

Epoxy coating protects steel from air contamination and rust. High performance finish extends life of steel in destructive conditions.

ENVIRONMENTAL

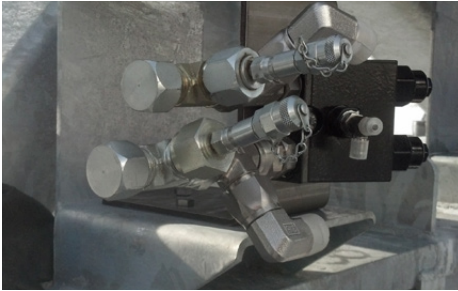

STAINLESS COMPONENTS

Upgrade to corrosion resistant idler frames, shafting, fitting and hardware.



PRESSURIZED PANELS

Prevents any hazardous gas or dust from entering the enclosure.



BELT COVERS

Protect conveyed materials from conditions and avoid dispersion of powders.

SELF-CONTAINED POWER

- » Useful in remote areas without electricity
- » Follow production of your track plant
- » Diesel engine mounted to undercarriage
- » Standard engine models or customizable



SLIDE-STAC™ CONVEYORS

- » Three radial stackers in one towable load
- » 60 or 70 foot (18 or 20m) long conveyors
- » Safely rolls conveyors from stacked load
- » Safer than picking or lifting off load



SPECIFICATION

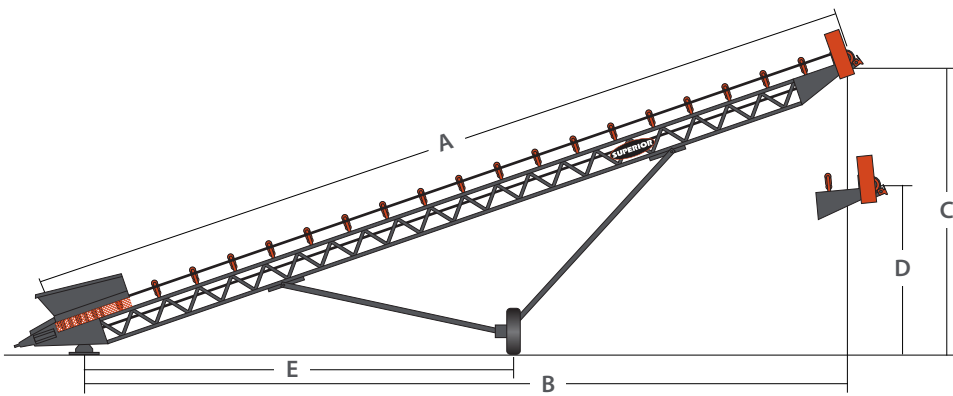

	50'		60'		70'		80'		95'		100'		110'		125'		150'	
	ft x in	m	ft x in	m	ft x in	m	ft x in	m	ft x in	m	ft x in	m	ft x in	m	ft x in	m	ft x in	m
OPERATING SPECIFICATIONS																		
(A) Conveyor Length	50'-0"	15.2	60'-0"	18.2	70'-0"	21.3	80'-0"	24.4	95'-0"	29.0	100'-0"	30.4	110'-0"	33.5	125'-0"	38.1	150'-0"	45.7
(B) Conveyor Ground Length	45'-9"	14.0	55'-2"	16.8	64'-9"	19.7	74'-0"	22.5	88'-7"	27.0	93'-0"	28.5	102'-0"	31.1	116'-2"	35.4	139'-9"	42.6
(C) Raised Height to Center of Pulley	17'-11"	5.5	21'-4"	6.5	24'-0"	7.3	28'-1"	8.3	31'-7"	9.6	33'-11"	10.3	36'-0"	11.0	40'-11"	12.2	49'-6"	15.1
(D) Lowered Height to Center of Pulley	12'-5"	3.8	13'-0"	3.9	14'-1"	4.3	14'-1"	4.2	14'-4"	4.3	13'-6"	4.1	17'-0"	5.2	19'-5"	5.9	17'-11"	5.5
(E) Anchor Pivot to Center of Axle	25'-5"	7.8	31'-2"	9.5	35'-9"	10.9	40'-11"	12.4	48'-4"	14.6	51'-5"	15.6	56'-7"	16.9	60'-2"	18.4	77'-3"	23.6

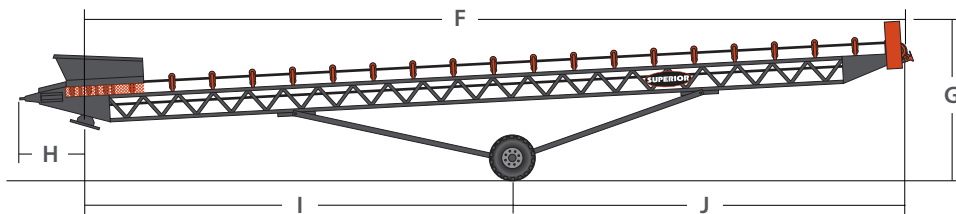

	50'		60'		70'		80'		95'		100'		110'		125'		150'	
	ft x in	m	ft x in	m	ft x in	m	ft x in	m	ft x in	m	ft x in	m	ft x in	m	ft x in	m	ft x in	m
TRAVEL SPECIFICATIONS																		
(F) Travel Length - Kingpin to Rear	49'-5"	15.1	59'-5"	18.1	74'-7"	22.6	63'-7"	19.4	73'-8"	22.3	78'-8"	24.0	60'-10"	18.6	70'-9"	21.6	80'-7"	24.6
(G) Travel Height	11'-8"	3.6	11'-0"	3.3	12'-1"	3.7	12'-3"	3.7	14'-1"	4.2	13'-6"	4.2	14'-1"	4.3	14'-0"	4.3	13'-11"	4.2
Travel Width	11'-6"	3.5	12'-0"	3.6	11'-9"	3.6	11'-9"	3.5	11'-9"	3.5	12'-0"	3.6	12'-8"	3.9	11'-11"	3.6	11'-11"	3.6
(H) Kingpin to End of Tow Eye	5'-3"	1.6	5'-3"	1.6	5'-2"	1.6	5'-2"	1.6	5'-2"	1.6	5'-3"	1.6	5'-11"	1.8	6'-0"	1.8	5'-11"	1.8
(I) Kingpin to Axle	24'-8"	7.6	30'-10"	9.4	36'-2"	11.0	40'-9"	12.5	48'-5"	14.8	53'-8"	16.4	29'-2"	8.9	33'-6"	10.2	49'-6"	15.1
(J) Axle to Head Pulley	24'-9"	7.6	28'-7"	8.7	33'-4"	10.2	22'-10"	7.0	25'-3"	7.3	24'-11"	7.6	25'-8"	7.9	31'-3"	9.5	25'-3"	7.7

WEIGHTS																		
	lbs	kg	lbs	kg	lbs	kg	lbs	kg	lbs	kg	lbs	kg	lbs	kg	lbs	kg	lbs	kg
Weight at Axle - 36" Belt Width	7,000	3,175	7,500	3,402	12,100	5,489	11,300	5,125	14,000	6,350	18,000	8,165	33,000	14,969	33,000	14,969	34,200	15,513
Weight at Kingpin - 36" Belt Width	625	283	925	420	1,100	499	3,000	1,361	2,500	1,134	2,000	907	3,500	1,588	3,500	1,588	10,200	4,627

NOTE: 80' (24.3m) and higher, have folds in structure for road travel.

STOCKPILE SPECIFICATION

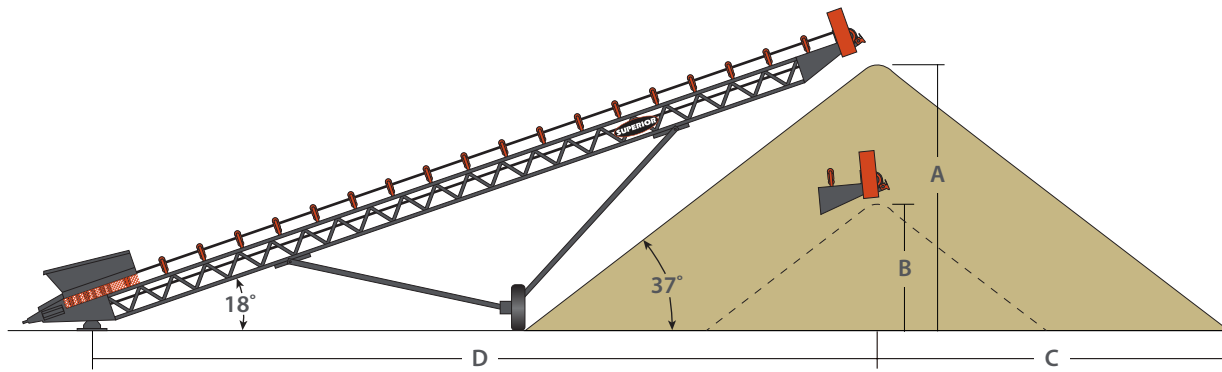

	50'		60'		70'		80'		95'		100'		110'		125'		150'	
	ft x in	m	ft x in	m	ft x in	m	ft x in	m	ft x in	m	ft x in	m	ft x in	m	ft x in	m	ft x in	m
STOCKPILE SPECIFICATIONS																		
(A) Stockpile Height	16'-5"	5.0	19'-6"	5.9	21'-10"	6.7	25'-10"	7.8	31'-0"	9.4	31'-7"	9.6	34'-11"	10.6	39'-9"	12.1	44'-4"	13.5
(B) Lowered Stockpile Height	11'-2"	3.4	11'-0"	3.4	12'-2"	3.7	13'-3"	4.1	13'-0"	4.0	16'-2"	4.9	17'-3"	5.3	17'-3"	5.3	13'-8"	4.2
(C) Radius of Pile	21'-0"	6.4	27'-0"	8.2	29'-0"	8.8	36'-6"	11.2	41'-4"	12.6	42'-9"	13.0	47'-0"	14.3	55'-4"	16.9	61'-10"	18.9
(D) Anchor Pivot to Center of Pile	47'-10"	14.6	57'-6"	17.6	67'-8"	20.6	76'-5"	23.3	90'-6"	27.6	95'-3"	29.1	104'-6"	31.9	119'-0"	36.2	143'-4"	43.7

Conveyor Length	Stockpile Height		Conical		90°		180°		270°	
	ft	ft x in / m	tons	metric tons	tons	metric tons	tons	metric tons	tons	metric tons

MAXIMUM STOCKPILE CAPACITIES (MANUAL PILES)*										
Conveyor Length	Stockpile Height	Stockpile Height	Conical	Conical	90°	90°	180°	180°	270°	270°
ft	ft x in / m	m	tons	metric tons	tons	metric tons	tons	metric tons	tons	metric tons
50'	16'-5"	5.0	408	370	1,751	1,589	3,093	2,807	4,435	4,025
60'	19'-6"	5.9	684	620	2,971	2,696	5,259	4,772	7,546	6,848
70'	21'-10"	6.7	992	900	4,426	4,016	7,860	7,132	11,294	10,240
80'	25'-10"	7.8	1,589	1,442	6,901	6,262	12,213	11,083	17,525	15,903
95'	31'-0"	9.4	2,747	2,493	11,834	10,738	20,920	18,984	30,007	27,229
100'	31'-7"	9.6	2,904	2,635	12,854	11,664	22,803	20,692	32,753	29,721
110'	34'-11"	10.6	3,923	3,560	17,140	15,553	30,356	27,546	43,573	39,540
125'	39'-9"	12.1	5,791	5,255	25,318	22,974	44,844	40,694	64,371	58,413
150'	44'-4"	13.5	8,033	7,289	36,755	33,353	65,476	59,416	94,198	85,479
180'	57'-2"	17.4	17,221	15,627	75,523	68,533	133,826	121,439	192,129	174,346
200'	63'-10"	19.4	23,980	21,760	104,981	95,264	185,981	168,767	266,982	242,271

* Assumptions based on material which has a 37° angle of repose and 100 PCF (1.6 t/m³) material density.

PHOTO GALLERY



50' (15.2M)



80' (24.4M)



95' (29.0M)



100' (30.5M)



110' (33.5M)



125' (38.0M)



150' (45.7M)



200' (60.0M)



SLIDE-STAC™ CONVEYORS

Three Radial Stacking Conveyors Packed in One Towable Load



SLIDE-STAC CONVEYORS



SUPERIOR COMPONENTS

Rock Face to Load Out™



SPECIFICATIONS

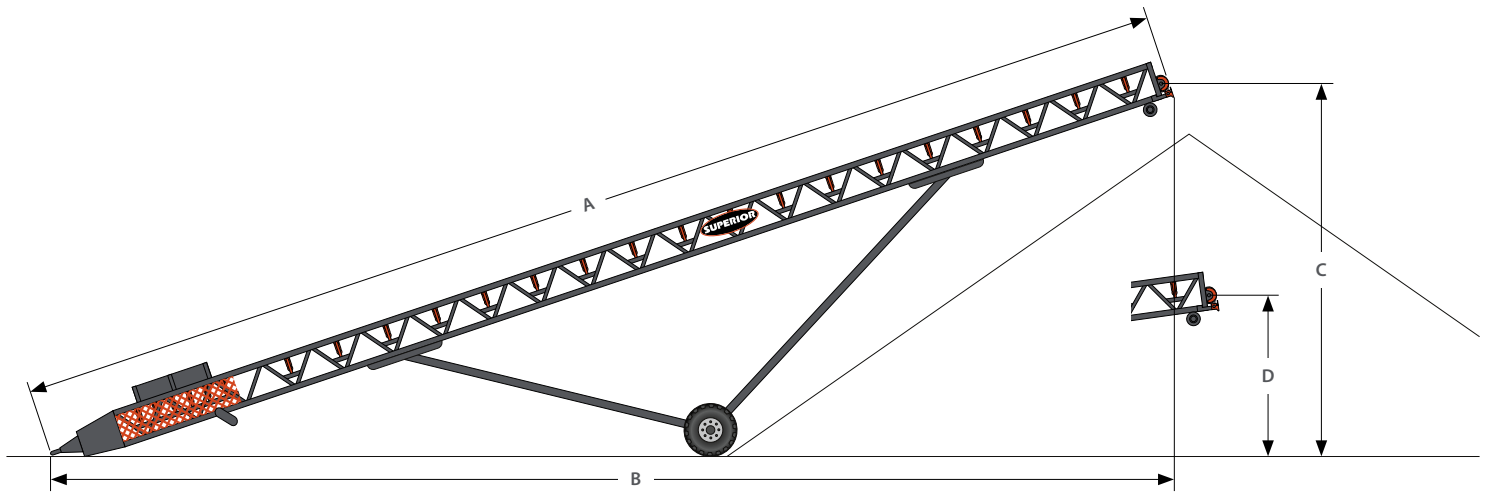

	36" x 60'						36" x 70'					
	Top Unit		Middle Unit		Trailer Unit		Top Unit		Middle Unit		Trailer Unit	
	ft x in	m	ft x in	m	ft x in	m	ft x in	m	ft x in	m	ft x in	m
OPERATING SPECIFICATIONS												
(A) Conveyor Length	59'-8"	18.2	59'-8"	18.2	59'-8"	18.2	69'-8"	21.2	69'-8"	21.2	69'-8"	21.2
(B) Conveyor Ground Length	56'-6"	17.2	56'-9"	17.3	56'-9"	17.3	66'-0"	20.1	66'-1"	20.1	66'-3"	20.2
(C) Raised Height to Center of Pulley	20'-7"	6.2	19'-10"	6.0	19'-11"	6.0	23'-8"	7.2	23'-6"	7.1	23'-1"	7.0
(D) Lowered Height to Center of Pulley	8'-9"	2.6	8'-4"	2.5	7'-10"	2.3	10'-3"	3.1	9'-9"	2.9	7'-6"	2.2
Highest Incline Angle	18.8°		17.8°		18.0°		18.5°		18.4°		18.0°	

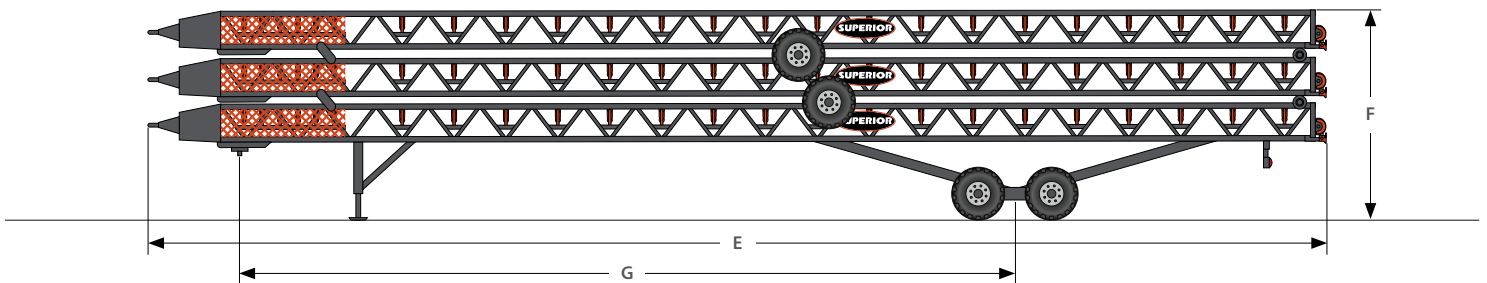

	36" x 60'		36" x 70'	
	ft x in	m	ft x in	m
TRAVEL SPECIFICATIONS				
(E) Travel Length (m)	59'-0"	18.0	69'-0"	21.0
(F) Travel Height (m)	13'-1"	4.0	13'-5"	4.0
Travel Width (m)	11'-11"	3.6	11'-11"	3.6
(G) Kingpin to Axle (m)	36'-11"	11.2	49'-2"	15.0
WEIGHTS				
	lbs	kg	lbs	kg
Weight at Axle (kg)	24,659	11,185	28,263	12,819
Weight at Kingpin (kg)	6,752	3,062	11,193	5,077



TRIPPER CONVEYOR

Build and Maintain Large Volume Stockpiles on Limited, Linear Footprints.

FEATURES

- » Conveyor system mounts on supports at any height
- » Heavy duty truss construction, designed around capacity requirements
- » For installations inside a building, channel frame construction with connection to rafters
- » Full length walkway for conveyor maintenance access
- » Tripper cart can direct material to either side of conveyor system via
 - » Discharge chutes with material diverter
 - » Reversing conveyor

APPLICATIONS

- » Build large volume, linear stockpiles with limited real estate
- » Build a linear surge pile over reclaim tunnel conveyor
- » Fill bunkers inside a building
- » Engineered to your application

PHOTO GALLERY





TRAILBLAZER® CONVEYOR

Pre-Assembled Portable Groundline Conveyor Folds into Road Portable Load.



FEATURES

- » 500' of overland conveyor in one load
- » Completely set up and operating in a single shift
- » Less overall horsepower than jump conveyors
- » Easy to relocate
- » Single transfer point reduces maintenance

Rock Face to Load Out™

 Patented Technology



FEATURES



01/ KINGPIN

Connects to fifth wheel hitch for towable package.

02/ SNUB PULLEY

Improves belt traction around drive pulley and reduces damaging tension.

03/ GRAVITY TAKE-UP

Ensures adequate belt tension near the drive pulley to avoid slippage.

04/ LIFTING EYE

Installed at joint points that require lifting assistance.

05/ CONVEYOR HINGE

Structure jointed in 10'-6" (3.2m) sections for folding and unfolding.

06/ SUPPORT STANDS

Conveniently stored over fifth wheel hitch during transportation.

07/ V-PLOW

Shields tail pulley and drive from onslaught of damaging fugitive material.

08/ SELF-ALIGNING IDLER

Concave-shaped urethane side guide rollers avoid abusing belting.

09/ NAVIGATOR® RETURN TRAINER

Constantly guides and center belt to present misalignment.

10/ CHEVRON® PULLEY

Ejects fugitive material for longer lasting pulleys and belting.

HIGHLIGHTS



84-FT (25.6M) PACKAGE



QUICK SET-UP



ROLL ON OR OFF DOVETAIL



SUPPORT STANDS

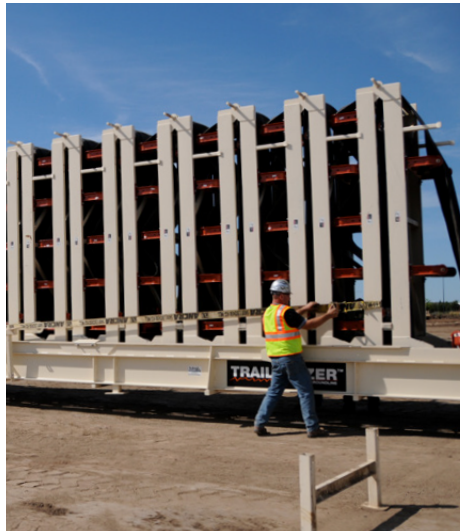

SECURE FOLDED SECTIONS



RECEIVING HOPPER



CRANKDOWN LANDING GEAR



AREA GUARDING



500-FT (150M)

SPECIFICATIONS

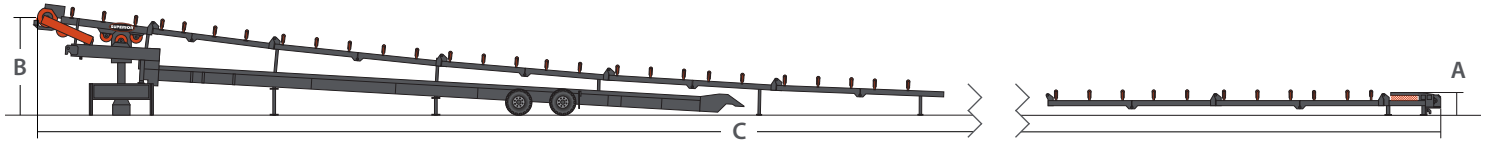

	48" x 250'		36" x 500'		42" x 500'	
	ft x in	m	ft x in	m	ft x in	m
OPERATING SPECIFICATIONS						
(A) Feed Height to Hopper	4'-5"	1.3	4'-2"	1.3	4'-4"	1.3
(B) Discharge Height to Center of Head Pulley	12'-9"	3.8	12'-6"	3.8	12'-6"	3.8
(C) Conveyor Length	250'-0"	75.6	500'-0"	152.4	500'-0"	152.4
CAPACITIES						
	STPH	MTPH	STPH	MTPH	STPH	MTPH
Capacity	2,000	1,814	1,000	907	1,500	1,360

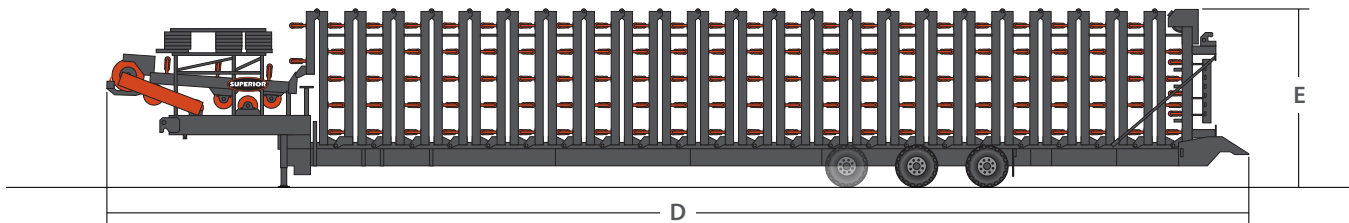

	48" x 250'		36" x 500'		42" x 500'	
	ft x in	m	ft x in	m	ft x in	m
TRAVEL SPECIFICATIONS						
(D) Travel Length (m)	56'-0"	17.1	89'-4"	27.2	92'-0"	28.0
(E) Travel Height (m)	14'-0"	4.2	14'-0"	4.3	14'-0"	4.3
Travel Width (m)	11'-11"	3.6	11'-4"	3.5	11'-10"	3.6
WEIGHTS						
	lbs	kg	lbs	kg	lbs	kg
Weight at Axle (kg)	40,000	18,144	41,500	18,824	47,500	21,545
Weight at Kingpin (kg)	35,500	16,102	28,000	12,700	40,000	18,143



ZIPLINE® CONVEYOR

Pre-Engineered, Modular Overland System Designed For Easy Installation

FEATURES

- » Quick and easy assembly
- » Pre-designed head, intermediate and tail sections
- » Customizable lengths up to 2500'
- » 30" to 48" belt widths

	ZIPLINE CONVEYOR	ZIPLINE EXT CONVEYOR
Belt Widths	30" - 42"	30" - 48"
Conveyor Lengths	Less than 1000'	1000' - 2500'
Intermediate Sections	Linking 10' sections with H-supports	40' table top stand alone sections.
Installation	Two-day installation time for 1000'	Requires hardware. Tower take-up will require erection. More time than standard Zipline Conveyor, but still much less time than engineered overland.
Engineering	Pre-engineered sections	Pre-engineered sections. Engineering required to design foundation for head take-up section. Engineering phase uses Belt Analysis software to confirm horsepower take-up accuracy.

Rock Face to Load Out™

 Patented Technology



ZIPLINE CONVEYOR FEATURES



01/ HEAD SECTION

40-foot (12m) long section is pre-assembled for quick installation.

02/ EXTERRA® PRIMARY BELT CLEANER

Designed with thicker blade tip/edge for longer lasting blades.

03/ NAVIGATOR® RETURN TRAINER

Constantly guides and centers belt to prevent misalignment.

04/ E-STOP OPTION

One or both sides switch with pull cable option.

05/ INTERMEDIATE SECTIONS

10-foot (3m), sections hook to top of H-supports without tools.

06/ H-SUPPORTS

2-foot (61cm) high, stands support intermediate section.

07/ IDLERS

Off-the-shelf rollers in standard CEMA frames attached with brackets and j-bolts.

08/ TAIL SECTION

Fully-assembled, skid-mounted section incorporates 5-foot (1.5m) gathering trough.

09/ CHEVRON® PULLEY

Ejects fugitive material for longer lasting pulleys and belting.



INTERMEDIATE SECTION



H-SUPPORTS



OFF-THE-SHELF IDLERS

ZIPLINE EXT CONVEYOR FEATURES



01/ BELTING

Superior supplies premium belting to match the application.

02/ SELF-ALIGNING IDLERS

Keep the belt on track, installed every 100'.

03/ SUPERIOR IDLERS

Eco application-specific idler seal for less drag in overland applications.

04/ DRIVE PULLEYS

Prime Mine Duty Drum Pulley.

05/ TAIL PULLEY

Mine Duty Chevron® Wing.

06/ INTERMEDIATE FRAME STRUCTURE

8" channel with 40' table top style sections. 2' tall supports on 20' spacing.

07/ TAKE-UP

Gravity tower at head end with Prime™ Mine Duty Pulleys.

08/ PRIMARY CLEANER

Superior Exterra® Primary Belt Cleaner.

09/ GATHERING TROUGH

With adjustable rubber flashing.

10/ SAFETY HANDRAIL OPTION

No wiring required, universally mounts to all idler frames.



PRE-ENGINEERED HEAD SECTION



PRE-ASSEMBLED INTERMEDIATE SECTION



PRE-ASSEMBLED TAIL SECTION

SPECIFICATIONS

ZIPLINE CONVEYOR MAXIMUM LENGTH ON FLAT GRADE										
Zipline Conveyor	Zipline EXT Conveyor									
BW	STPH	30 HP	50 HP	60 HP	75 HP	100 HP	120 HP	150 HP	200 HP	250 HP
30"	500	500'	1000'		1500'	2000'	2400'			
30"	500		1000'							
36"	1000		500'		1000'					
36"	1000				1150'	1650'	2050'	2600'		
42"	1500			500'		1000'				
42"	1500					1150'	1400'	1850'	2650'	
48"	2000						800'	1200'	2000'	2500'

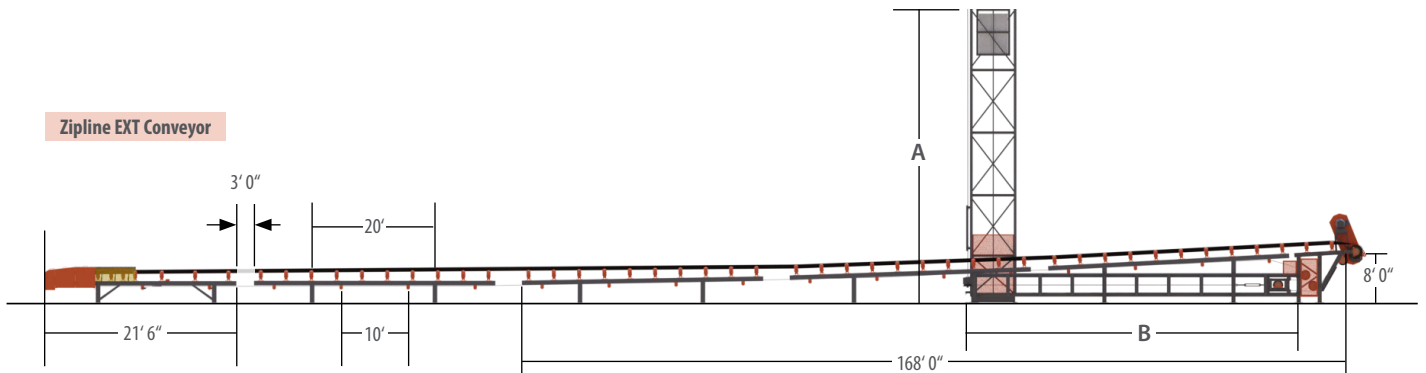
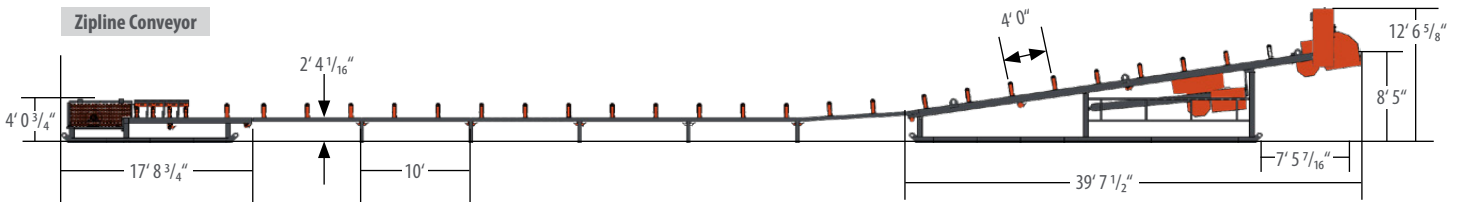

	ft x in	m	ft x in	m	ft x in	m
ZIPLINE EXT CONVEYOR TAKE-UP TRAVEL DIMENSIONS						
Travel	20'	6.1	30'	9.1	40'	12.2
A	33'	9.9	43'	13.0	53'	16.0
B	32'	9.8	42'	12.9	52'	15.9

UPGRADES



BELT COVERS

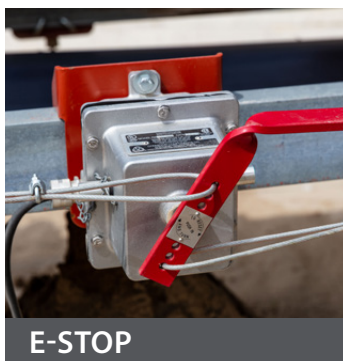

E-STOP

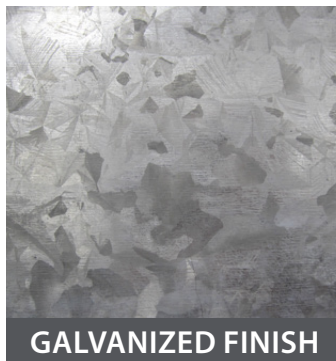

GALVANIZED FINISH



RECEIVING HOPPER



OVERLAND CONVEYOR

Custom Engineered Structural System With Performance-Matched Conveyor Components



40-TON HAUL TRUCK

Number of Trucks	2
Tons Per Load	40
Cycle Time	10 Minutes
Purchase Price	\$300,000.00
Depreciation Schedule	7 Years
Expected Life	30,000 Hours
Maintenance/Fuel Per Hour	\$56.00
Lifetime Maintenance	\$70,000.00
Cost Per Ton	\$0.43

42" (106CM) OVERLAND CONVEYOR

Net Elevation Change	40' (12m)
Tons Per Hour	500
Horsepower	50
Purchase Price	\$250,000.00
Depreciation Schedule	20 Years
Site Preparation	\$10,000
Electricity (kwh) Per Hour	\$0.08
Conveyor Sections	1
Cost Per Ton	\$0.03

1,000' (305m) haul length; 10 hours/day; 5 days/week; \$25.00/hour labor
 Conveyor: 3 hours/20' (6m) installation; 3 minutes/hour maintenance; 1% of total cost/4 years bearings; 2% of total cost/2 years idlers; 1% of total cost/4 years pulleys; \$20/foot belting replaced every 5 years

Rock Face to Load Out™



TRUSS FRAME OVERLAND



COST PER TON (2,500-FOOT / 762-METER TRANSFER)

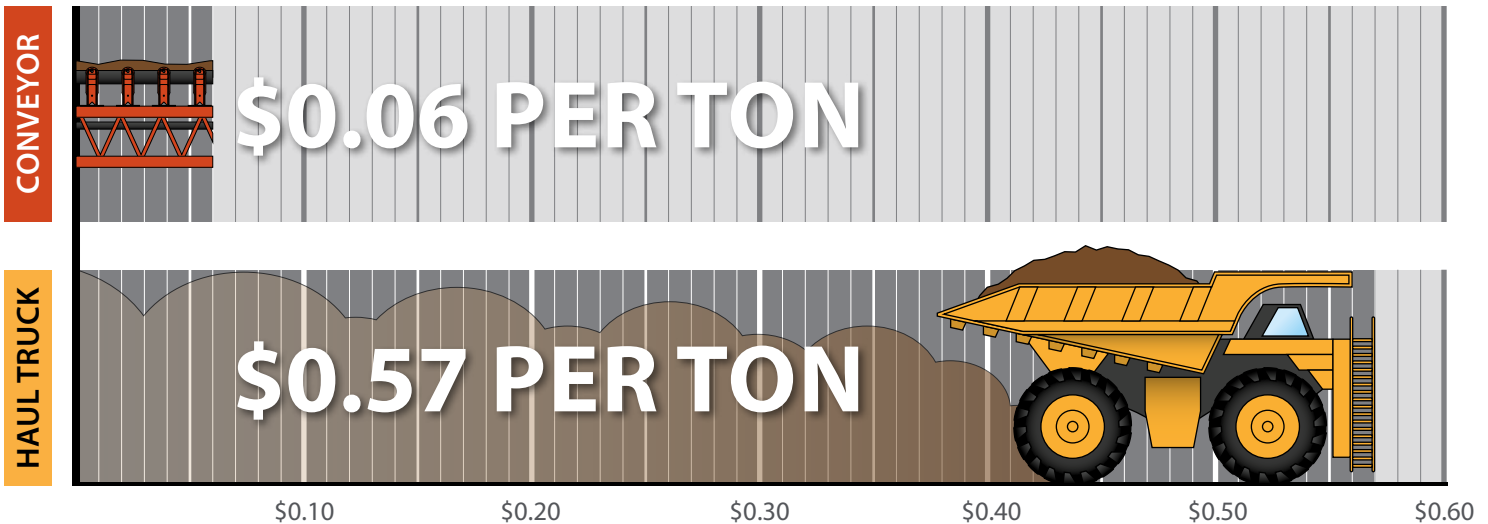

CHANNEL FRAME OVERLAND



COST PER TON BY DEGREE OF INCLINE

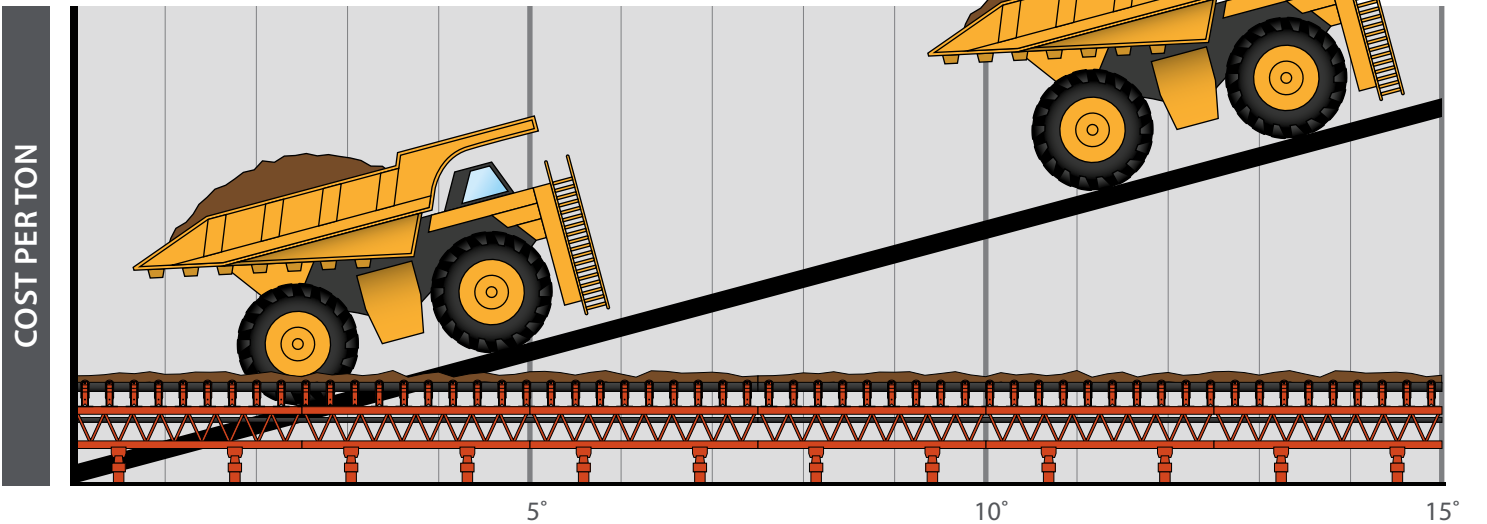

ELEVATED OVERLAND SOLUTIONS



DISADVANTAGES OF HAUL TRUCKS

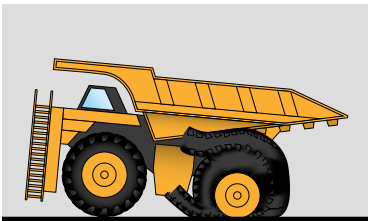

- » Haul trucks are negatively affected by unstable fuel prices.
- » Conveyors use electricity. Electricity costs are fairly stable compared to diesel prices.

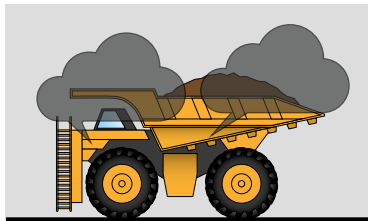

- » Truck dust, noise and traffic concerns neighborhoods.
- » Conveyors can be designed to blend with environment.

- » Additional downtime is required for maintenance.
- » Conveyor parts are consistently available locally.

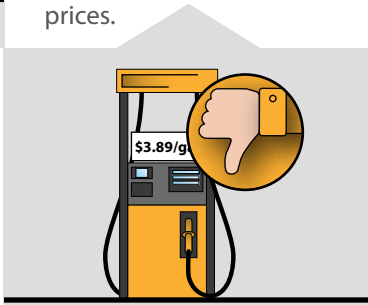

- » Trucks emit and stir pollution along entire transfer path.
- » Conveyors drastically reduce particle emissions.

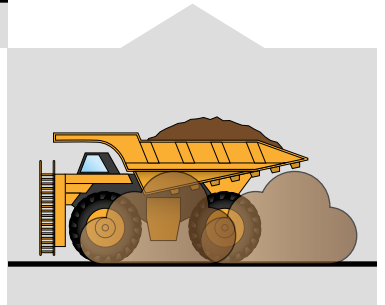

SUPERIOR CONVEYOR COMPONENTS

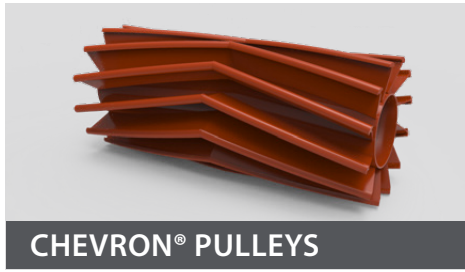

CHEVRON® PULLEYS



DRUM PULLEYS

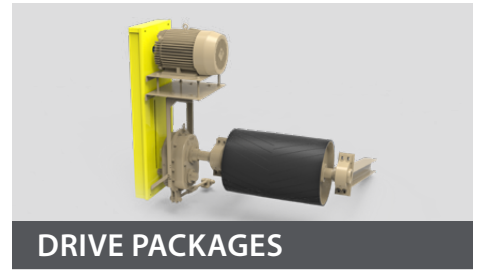

DRIVE PACKAGES



CONVEYOR IDLERS



MOXIE® ROLLS



URATHON® RETURN ROLLS



NAVIGATOR® RETURN TRAINERS



EXTERRA® BELT CLEANERS



IMPACT BEDS

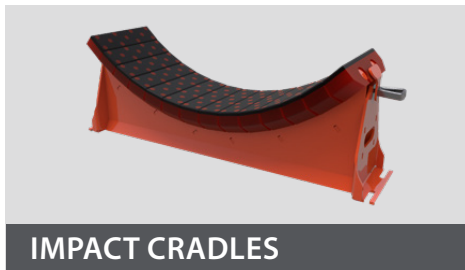

IMPACT CRADLES



SAFETY GUARDING



BELT COVERS

ENVIRONMENTAL IMPACT (POUNDS OF PM-10 EMISSIONS PER YEAR)

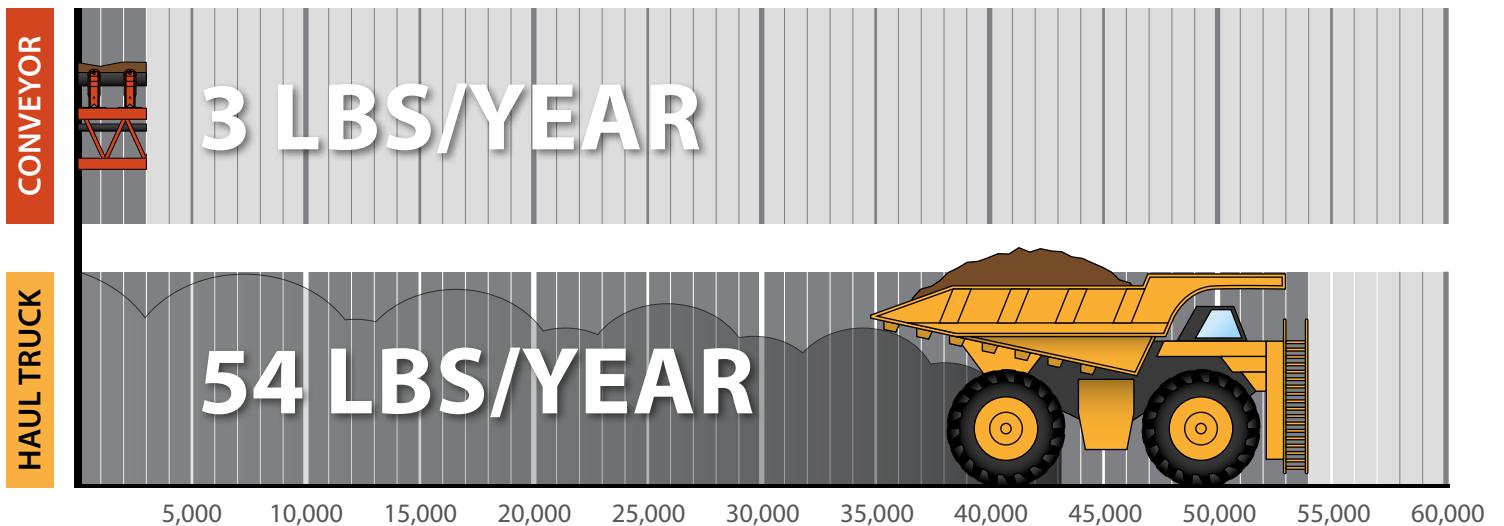

Rock Face to Load Out™

OVERLAND CONVEYOR

OVERLAND CONVEYOR OPERATION BENEFITS



CONVEYORS OPERATE AT MAXIMUM EFFICIENCY



CONVEYORS MAINTAIN PRODUCT QUALITY

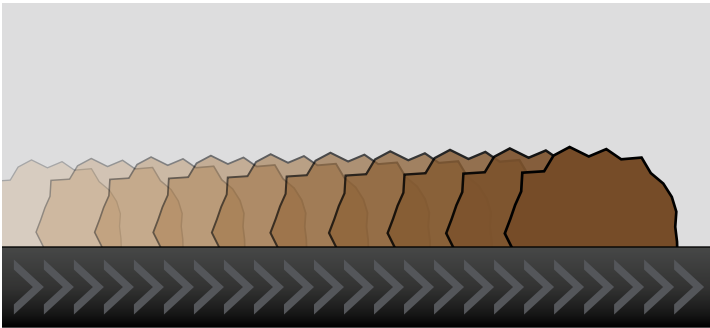

CONVEYORS MAINTAIN CONTINUOUS FLOW



CONVEYORS ARE LESS AFFECTED BY WEATHER



IN-PLANT CONVEYORS

Conveyor and Components Custom-Engineered from Head to Tail



Rock Face to Load Out™



PHOTO GALLERY





STACKABLE CONVEYORS

Bundle Up to 8 Conveyors in One Load for Substantial Freight Savings



Rock Face to Load Out™



FEATURES



TOW EYE



EXTERRA SFL DUAL



MOXIE ROLLS

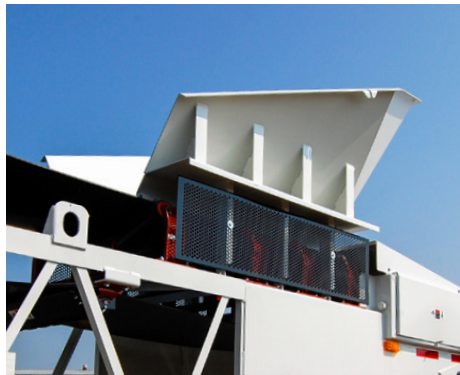

RECEIVING HOPPER



HINGED TAIL BEND



HAND CRANK AXLE JACKS

PORTABILITY

- » Tow Eye

OPERATION

- » 6-foot (1.8m) Discharge Support
- » Telescoping Tail Support Legs
- » Hinged Tail Bend

MAINTENANCE

- » Exterra® Primary Belt Cleaner
- » Moxie® Rolls
- » Urathon® Return Rolls
- » Impact Rolls
- » Radial Receiving Hopper
- » Vulcanized Splice

ENVIRONMENT

- » Epoxy Paint
- » Hot Dipped Galvanized Finish

OTHER

- » Belt Scale

STACKABLE PLUS

- » Heavier Truss
- » Anchor Pivot Plate
- » Tow Eye
- » Manual Raise Undercarriage
- » 9-foot (2.7m) Hinged Tail Bend
- » Hand Crank Axle Jacks
- » Swivel Boxes

SPECIFICATIONS

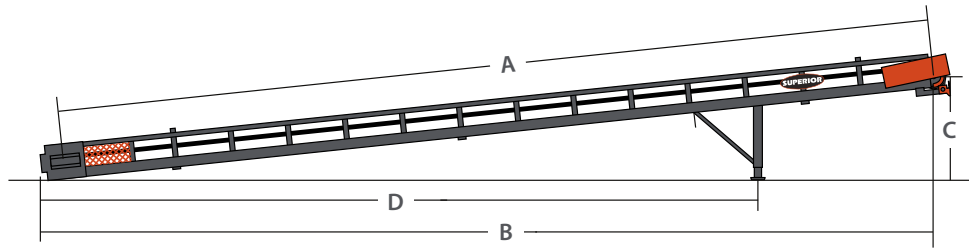

	50'		60'	
	ft x in	m	ft x in	m
STACKABLE WITH SUPPORT OPERATING SPECIFICATIONS				
(A) Conveyor Length	50'-0"	15.2	60'-0"	18.3
(B) Conveyor Ground Length	48'-8"	14.8	59'-8"	18.1
(C) Raised Height to Center of Pulley	Up to 17'-11"	Up to 5.5	Up to 21'-0"	Up to 6.4
Lowered Height to Center of Pulley	12'-5"	3.8	12'-5"	3.8
(D) Anchor Pivot to Center of Axle	25'-5"	7.8	31'-2"	9.5

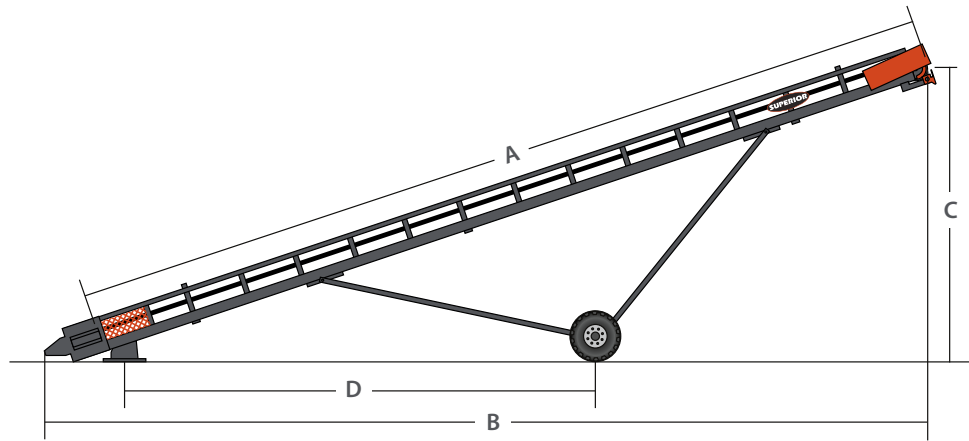

	50'		60'	
	ft x in	m	ft x in	m
STACKABLE PLUS WITH UNDERCARRIAGE OPERATING SPECIFICATIONS				
(A) Conveyor Length	50'-0"	15.2	60'-0"	18.3
(B) Conveyor Ground Length	49'-2"	15.0	57'-3"	17.4
(C) Raised Height to Center of Pulley	16'-7"	5.0	19'-4"	5.8
Lowered Height to Center of Pulley	9'-0"	2.7	7'-11"	2.4
(D) Anchor Pivot to Center of Axle	26'-10"	8.2	32'-9"	10.0
Maximum Stockpile Height - Feet	18'-6"	5.7	21'-6"	6.6

OPERATING CAPACITIES				
	yards ³	m ³	yards ³	m ³
Maximum Stockpile Capacity	430	328	680	519

OPERATING TONNAGE				
	tons	metric tons	tons	metric tons
18° Straight Incline	580	526	920	834

SPECIFICATIONS CONTINUED

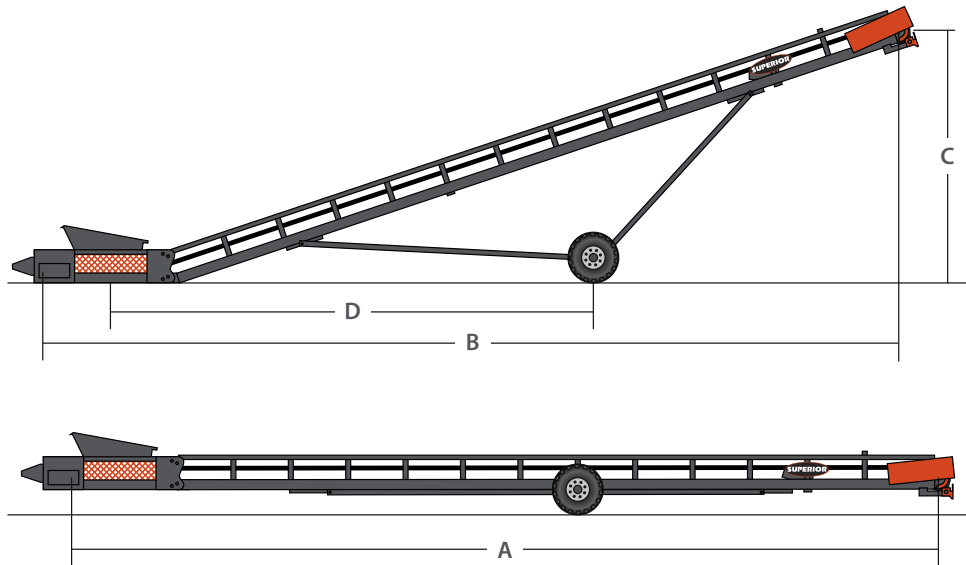

	50'		60'	
	ft x in	m	ft x in	m
STACKABLE PLUS WITH BEND OPERATING SPECIFICATIONS				
(A) Conveyor Length - Center of Pulley to Center of Pulley	50'-0"	15.2	60'-0"	18.3
(B) Conveyor Ground Length	47'-5"	14.4	57'-0"	17.3
(C) Raised Height to Center of Pulley	15'-5"	4.7	18'-6"	5.6
Lowered Height to Center of Pulley	4'-6"	1.3	4'-7"	1.3
(D) Anchor Pivot to Center of Axle	28'-2"	8.6	38'-10"	11.8
Maximum Stockpile Height	19'-6"	6.0	22'-6"	6.9
OPERATING CAPACITIES				
	yards ³	m ³	yards ³	m ³
Maximum Stockpile Capacity	490	374	780	596
OPERATING TONNAGE				
	tons	metric tons	tons	metric tons
19° Straight Incline	660	598	1,100	997



SLIDE-PAC™ CONVEYORS

Quickly and Safely Roll Conveyors From Transport to Operation Instead of Risky Lifting



Rock Face to Load Out™



HIGHLIGHTS



3 TRANSFER CONVEYORS IN A SINGLE LOAD



EASILY SLIDE CONVEYORS ON AND OFF

SPECIFICATIONS

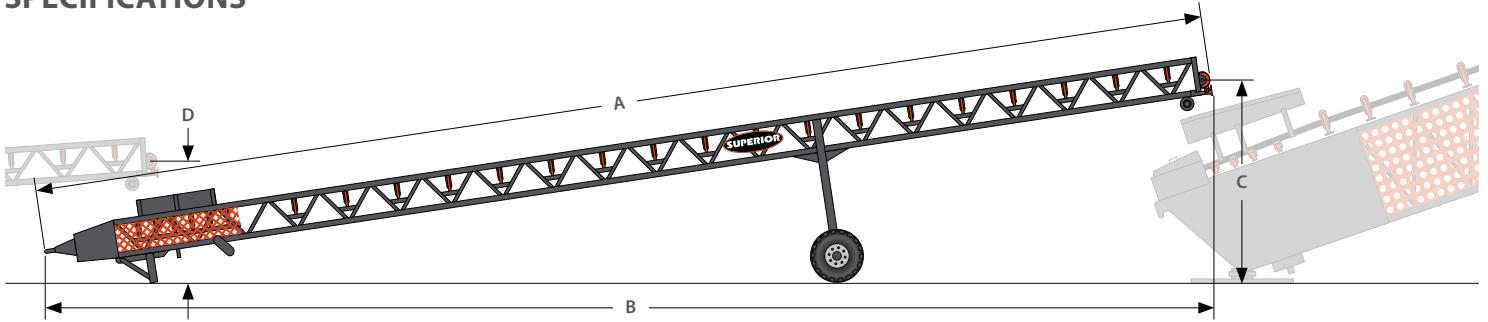

60'						70'						80'					
Top Unit		Middle Unit		Trailer Unit		Top Unit		Middle Unit		Trailer Unit		Top Unit		Middle Unit		Trailer Unit	
ft x in	m	ft x in	m	ft x in	m	ft x in	m	ft x in	m	ft x in	m	ft x in	m	ft x in	m	ft x in	m

OPERATING SPECIFICATIONS																		
(A) Conveyor Length (m)	59'-8"	18.2	59'-8"	18.2	59'-8"	18.2	69'-8"	21.2	69'-8"	21.2	69'-8"	21.2	79'-8"	24.2	79'-8"	24.2	79'-8"	24.2
(B) Conveyor Ground Length (m)	58'-9"	17.9	59'-6"	18.1	59'-7"	18.1	68'-11"	21.0	69'-3"	21.1	69'-6"	21.1	79'-1"	24.1	79'-4"	24.1	79'-8"	24.2
(C) Raised Height to Center of Pulley (m)	12'-9"	3.8	10'-2"	3.0	7'-3"	2.2	12'-10"	3.9	10'-4"	3.1	7'-0"	2.1	12'-3"	3.7	9'-11"	3.0	6'-10"	2.0
(D) Lowered Height to Center of Pulley (m)	7'-6"	2.2	7'-5"	2.2	6'-8"	2.0	7'-6"	2.2	7'-6"	2.2	6'-6"	1.9	7'-3"	2.2	7'-3"	2.2	6'-6"	2.0

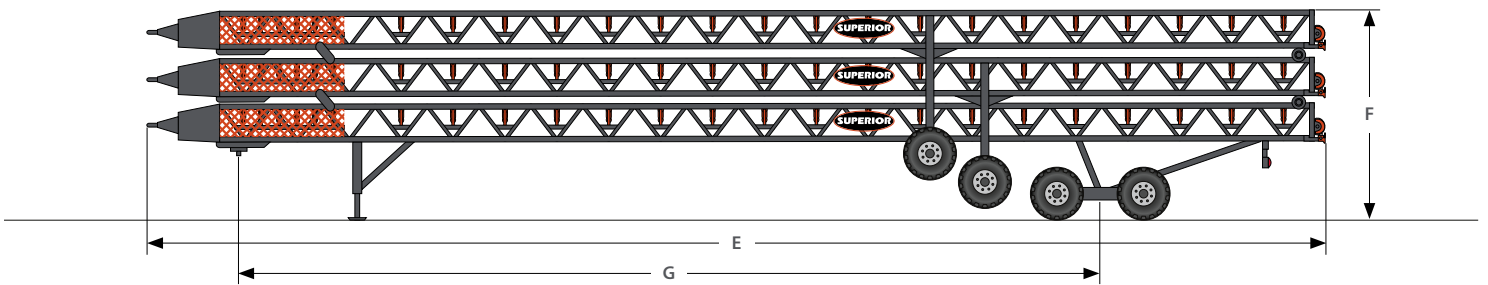

36" x 60'		36" x 70'		42" x 70'		36" x 80'	
ft x in	m	ft x in	m	ft x in	m	ft x in	m

TRANSPORT SPECIFICATIONS								
(E) Travel Length	59'-0"	18.0	69'-0"	21.0	69'-0"	21.0	79'-0"	24.0
(F) Travel Height	13'-6"	4.1	13'-6"	4.1	13'-6"	4.1	13'-6"	4.1
Travel Width	10'-1"	3.0	9'-11"	3.0	10'-10"	3.3	9'-11"	3.0
(G) Kingpin to Axle	44'-9"	13.6	54'-9"	16.6	54'-9"	16.6	64'-9"	19.7

WEIGHTS								
	lbs	kg	lbs	kg	lbs	kg	lbs	kg
Weight at Axle	18,945	8,593	21,000	9,525	24,300	11,022	22,044	9,998
Weight at Kingpin	10,018	4,544	12,800	5,805	15,600	7,076	13,871	6,291



JUMP CONVEYORS

Workhorse Transfer Conveyors Are Easily Customized For Your Operation



Rock Face to Load Out™



FEATURES

OPERATION

- » Radial Receiving Hopper
- » 6-foot (1.8m) Discharge Support
- » Belt Scale

MAINTENANCE

- » Exterra® Primary Belt Cleaner
- » Moxie® Rolls
- » Urathon® Return Rolls
- » Impact Rolls
- » Auto Greaser

MOBILITY

- » Power Travel
- » Strut Axle
- » Landing Gear
- » Fifth Wheel Hitch
- » Lights and Brakes
- » Tow Eye

SPECIFICATIONS

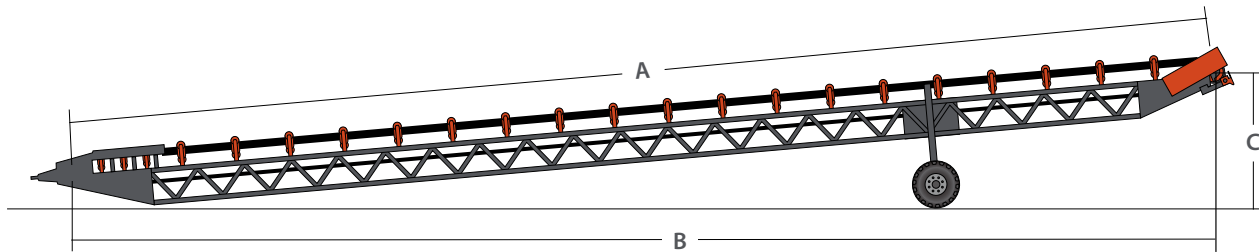

	40'		50'		60'		80'		100'	
	ft x in	m	ft x in	m	ft x in	m	ft x in	m	ft x in	m
OPERATING SPECIFICATIONS										
(A) Conveyor Length	40'-0"	12.1	50'-0"	15.2	60'-0"	18.2	80'-0"	24.4	100'-0"	30.5
(B) Conveyor Ground Length	40'-3"	12.2	45'-10"	14.0	49'-4"	15.0	79'-9"	24.4	94'-9"	28.9
(C) Raised Height to Center of Pulley	11'-7"	3.5	12'-4"	3.7	13'-7"	4.1	12'-2"	3.7	11'-11"	3.6
Lowered Height to Center of Pulley	7'-4"	2.2	7'-10"	2.3	6'-11"	2.1	6'-10"	2.0	7'-9"	2.3

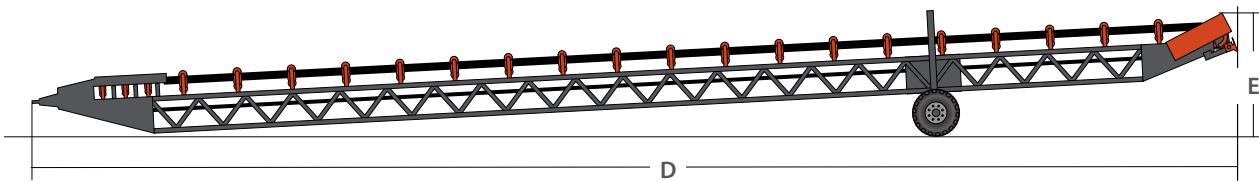

	40'		50'		60'		80'		100'	
	ft x in	m	ft x in	m	ft x in	m	ft x in	m	ft x in	m
TRAVEL SPECIFICATIONS										
(D) Travel Length - 36" Belt Width	44'-8"	13.6	54'-9"	16.7	64'-9"	19.8	84'-9"	25.9	71'-6"	21.7
(E) Travel Height - 36" Belt Width	8'-11"	2.7	8'-10"	2.6	9'-4"	2.8	9'-5"	2.8	14'-1"	4.2
Travel Width - 36" Belt Width	8'-6"	2.5	8'-0"	2.4	9'-3"; Dual 10'-1"	2.8; Dual 3.0	9'-1"	2.7	11'-11"; Dual 10'-5"	3.6; Dual 3.1
WEIGHTS										
	lbs	kg	lbs	kg	lbs	kg	lbs	kg	lbs	kg
Weight at Axle - 36" Belt Width	5,186	2,352	4,553	2,065	4,700	2,131	7,000	3,175	8,700	3,946
Weight at Kingpin - 36" Belt Width	1,463	663	1,910	866	2,400	1,088	3,000	1,360	2,900	1,315



EXTENDER CONVEYOR

Maintain One Transfer Conveyor Versus Several of Equal Length



ADJUST BASED ON STOCKPILE LOCATION

FEATURES

- » Eliminate need for multiple transfer conveyors
- » One transfer point and electrical supply to maintain
- » Hydraulically extend or retract to meet transfer lengths
- » 80' (24.3m) main frame conveyor
- » Extender conveyor options:
 - » 70' (21.3m) internal stinger conveyor
 - » 50' (15.2m) stinger plus 70' (21.3m) foldable tail
 - » 70' (21.3m) stinger plus 80' (24.3m) slide-on conveyor

PHOTO GALLERY



70' (21.3M) EXTENDABLE STINGER CONVEYOR



HYDRAULIC LANDING LEGS



OPTIONAL TAIL HYDRAULIC FOLD



OPTIONAL TAIL SECTION UNFOLDING



UNLOADING OPTIONAL SLIDE-ON CONVEYOR



RAISE LEGS TO REACH FEED POINT



RAZERTAIL[®] TRUCK UNLOADER

Unload From Truck to Target to Avoid Double Handling Material

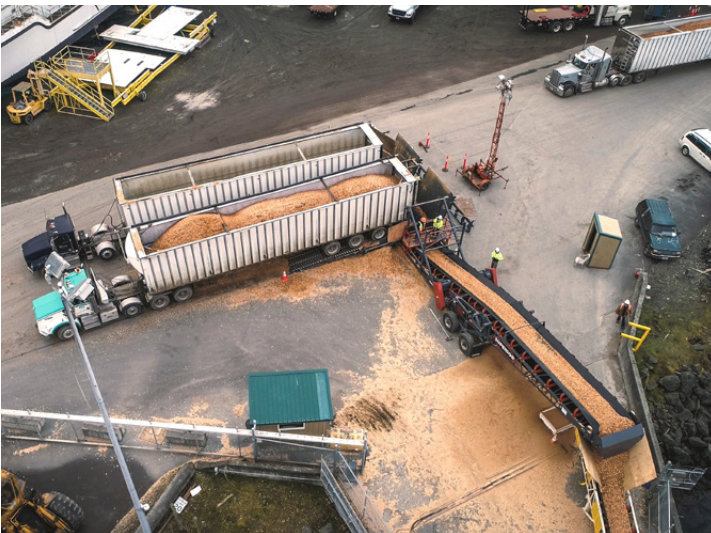

DUAL LANE DOUBLE TRUCK TRAFFIC

FEATURES

- » Maintain material quality from truck to stockpile or transportation system
- » Handles multiple truck/trailer styles including belly, end and side dump, plus haul trucks
- » 2.0 to 3.0 minute truck cycle times for efficient unloading
- » Patented self-cleaning ramps dump any overflow material to hopper

FEATURES



01/ CHEVRON® PULLEY

Ejects fugitive material for longer lasting pulleys and belting.

02/ TAIL PULLEY ACCESS

Access steps to operator platform is hinged for convenient access to tail pulley and take-up.

03/ SELF-CLEANING RAMPS

Hydraulically-controlled ramps automatically or manually dump any leftover material into hopper.

04/ DRIVE OVER GRATES

Versus permanently fixed, these bolt on grates can be removed for maintenance.

05/ OPERATOR PLATFORM(S)

Equip on one or both sides of hopper area to monitor production.

06/ HYDRAULIC POWERFOLD

Inverted design protects cylinder rods from debris during operation.

07/ WRAP DRIVE

Accessible from ground level, the combination of pulleys creates better tensioning and reduced spillage.

08/ TRUSS FRAME

Versus channel frame designs, this robust design is less prone to bending.

09/ ADJUSTABLE HEIGHT DISCHARGE

Maintains structural rigidity under heavy materials and wind loads.

10/ ADJUSTABLE FLOW GATE

You set the height to control the flow of material from the hopper.

11/ IMPACT IDLERS

Rubber cushioned idlers absorb shock to protect belt from falling material.

MODELS



48-INCH (1,219MM)

- » Up to 1,000 STPH (907 MTPH)
- » Up to 4-inch minus (101mm) materials lumps
- » 10-foot (3m) x 5-foot (1.5m) grate unload area
- » 5-inch (127mm) grate openings
- » Accommodates belly or end dump trucks
- » Dual lane upgrade for increased truck traffic



72-INCH (1,828MM)

- » Up to 1,500 STPH (1,339 MTPH)
- » Up to 4-inch minus (101mm) materials lumps
- » 10-foot (3m) x 7-foot (2.1m) grate unload area
- » 5-inch (127mm) grate openings
- » Accommodates belly or end dump trucks
- » Dual lane upgrade for increased truck traffic



48-INCH (1,219MM) HAUL TRUCK

- » Up to 1,000 STPH (907 MTPH)
- » Up to 6-inch minus (152mm) materials lumps
- » 12-foot (3.7m) x 5-foot (1.5m) grate unload area
- » 7-inch (178mm) grate openings
- » Accommodates rigid and articulated 30-ton haul trucks



72-INCH (1,828MM) HAUL TRUCK

- » Up to 2,000 STPH (1,814 MTPH)
- » Up to 8-inch minus (203mm) materials lumps
- » 15'-2" (4.6m) x 7-foot (2.1m) grate unload area
- » 9-inch (229mm) grate openings
- » Accommodates rigid and articulated 40-ton haul trucks

FEATURES



MANUAL ONBOARD RAMPS



EARTHEN RAMPS



ADJUSTABLE DISCHARGE



SELF-CONTAINED POWER



OPERATOR PLATFORM(S)



DISCHARGE HOOD



SELF-CLEANING RAMPS

TRUCK ACCESS

- » Hydraulic Onboard Truck Ramps
- » Manual Folding Onboard Truck Ramps
- » Earthen Ramps

OPERATION

- » Folding Adjustable Height Discharge Conveyor
- » Onboard, Self-Contained Power
- » Wireless Remote Control
- » Operator Platform(s)
- » Hydraulic Landing Jacks
- » Discharge Hood

MAINTENANCE

- » Self-Cleaning Ramps
- » Moxie® Rolls
- » Impact Idlers

APPLICATIONS



BELLY DUMP



END DUMP

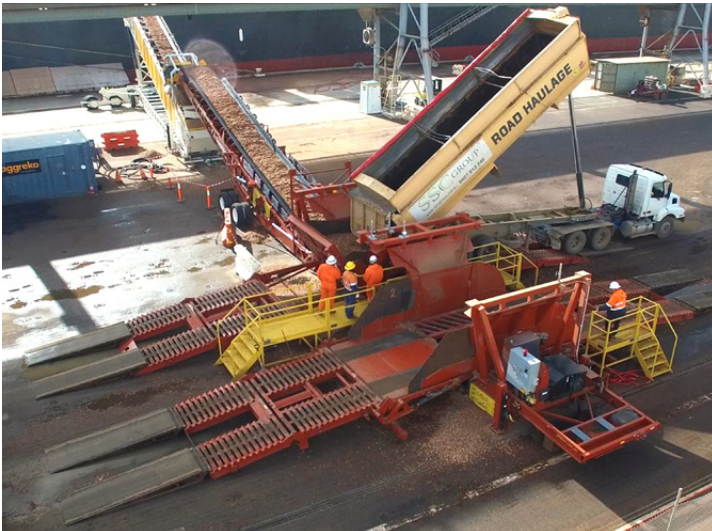

DUAL LANE



RAILCAR LOADING



BARGE LOADING



SHIP LOADING

OPERATING SPECIFICATIONS

48-INCH BELT WIDTH CONVEYOR



48-INCH BELT WIDTH, WITH FOLDING DISCHARGE CONVEYOR

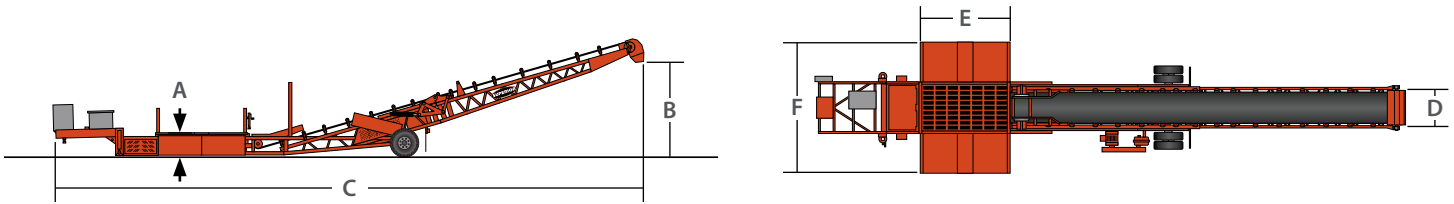

48-INCH BELT WIDTH, DUAL LANE WITH FOLDING DISCHARGE CONVEYOR

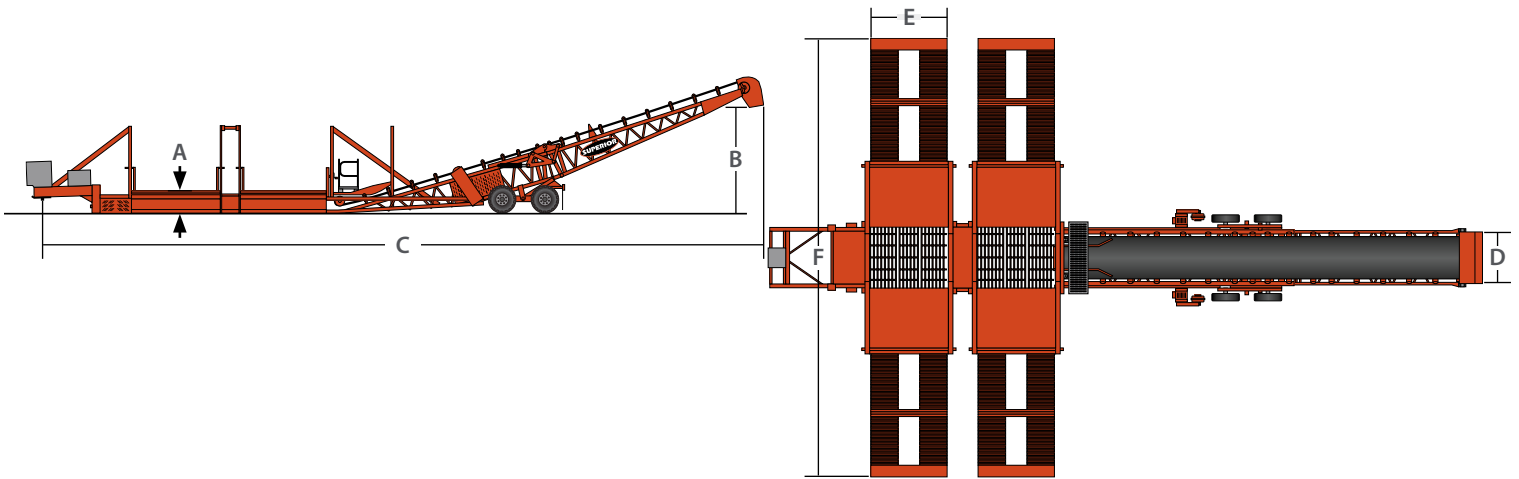

	48" (fixed height discharge)		48" (with adjustable discharge)		48" Haul Truck (not shown)		48" Dual Lane	
	Imperial	Metric	Imperial	Metric	Imperial	Metric	Imperial	Metric
Capacity	1,000 stph	907 mtph	1,000 stph	907 mtph	1,000 stph	907 mtph	1,000 stph	907 mtph
Maximum Material Size	4" Minus	Minus 101mm	4" Minus	Minus 101mm	6" minus	Minus 152mm	4" Minus	Minus 101mm
Cycle Time in Minutes	3.0 / 30 Short Tons	3.0 / 27 Metric Tonnes	3.0 / 30 Short Tons	3.0 / 27 Metric Tonnes	3.0 / 30 Short Tons	3.0 / 27 Metric Tonnes	3.0 / 30 Short Tons	3.0 / 27 Metric Tonnes
(A) Earth Ramp Height	25"	635mm	25"	635mm	28"	711 mm	29"	737mm
(B) Discharge Height	6'-1"	1.9 m	7'-2" - 11'-5"	2.2 - 3.5 m	7'-2" - 11'-5"	2.2 - 3.5 m	7'-2" - 11'-5"	2.2 - 3.5 m
(C) Conveyor Length	55'-1"	16.8 m	73'-3"	22.3 m	74'-11"	22.8 m	89'-2"	27.2 m
(D) Conveyor Width	5'-0"	1.5 m	5'-0"	1.5 m	5'-0"	1.5 m	5'-0"	1.5 m
(E) Load Ramp Width	10'-2"	3.1 m	10'-2"	3.1 m	11'-9"	3.6 m	10'-4"	3.1 m
(F) Load Ramp Length	22'-8"	6.8 m	22'-8"	6.8 m	22'-9"	6.9 m	55'-0"	16.8 m

TRAVEL SPECIFICATIONS

48-INCH BELT WIDTH CONVEYOR

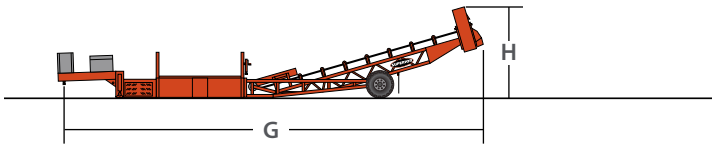

48-INCH BELT WIDTH, WITH FOLDING DISCHARGE CONVEYOR

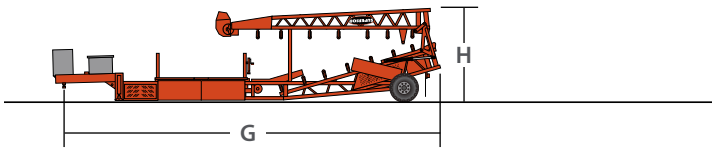

48-INCH BELT WIDTH, DUAL LANE WITH FOLDING DISCHARGE CONVEYOR

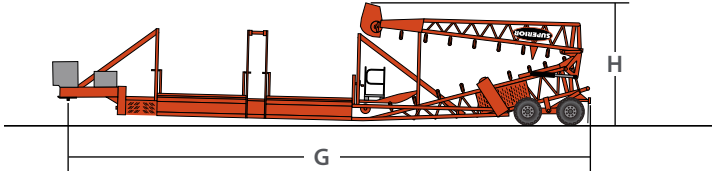

	48" (fixed height discharge)		48" (with adjustable discharge)		48" Haul Truck (not shown)		48" Dual Lane	
	Imperial	Metric	Imperial	Metric	Imperial	Metric	Imperial	Metric
(G) Travel Length	53'-4"	16.3 m	46'-8"	14.2 m	50'-5"	15.4 m	67'-8"	20.6 m
(H) Travel Height	12'-6"	3.8 m	12'-6"	3.8 m	12'-6"	3.8 m	15'-7"	4.8 m
Travel Width	12'-8"	3.9 m	11'-1"	3.3 m	11'-9"	3.6 m	10'-10"	3.3 m
Weight at Axle	16,100 lb	7,300 kg	19,500 lb	8,845 kg	22,000 lb	9,980 kg	N/A	N/A
Weight at Axle*	19,800 lb	8,980 kg	23,700 lb	10,750 kg	N/A	N/A	N/A	N/A
Weight at Axle**	N/A	N/A	24,800 lb	11,250 kg	N/A	N/A	54,500 lb	24,720 kg
Weight at Kingpin	11,300 lb	5,125 kg	13,100 lb	5,940 kg	17,600 lb	7,980 kg	N/A	N/A
Weight at Kingpin*	16,300 lb	7,395 kg	19,600 lb	8,890 kg	N/A	N/A	N/A	N/A
Weight at Kingpin**	N/A	N/A	22,300 lb	10,115 kg	N/A	N/A	45,500 lb	20,640 kg
Axles	Single		Single/Tandem		Tandem		Tridem	

*Tri-Fold Ramps, **Hydraulic Tri-Fold Ramps

OPERATING SPECIFICATIONS

72-INCH BELT WIDTH, WITH FOLDING DISCHARGE CONVEYOR

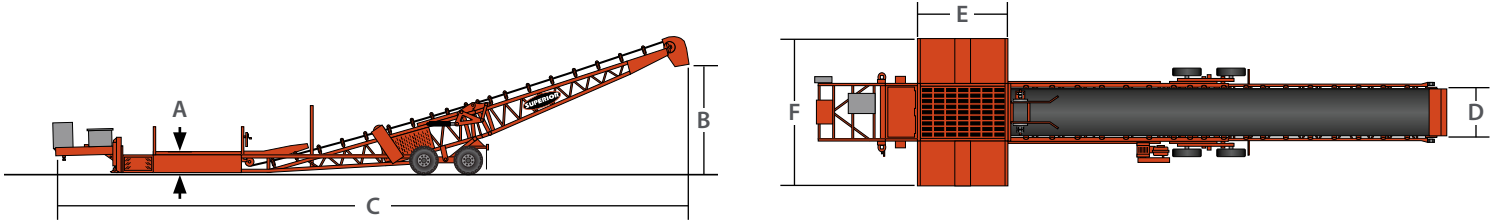

72-INCH BELT WIDTH, HAUL TRUCK, WITH FOLDING DISCHARGE CONVEYOR

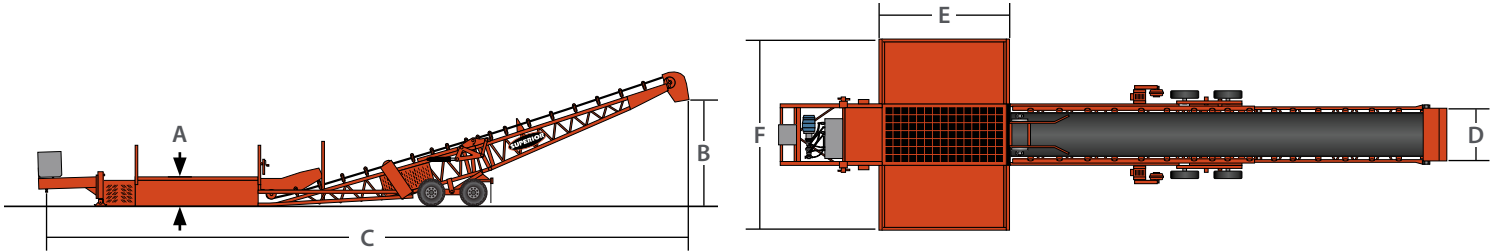

72-INCH BELT WIDTH, DUAL LANE WITH FOLDING DISCHARGE CONVEYOR

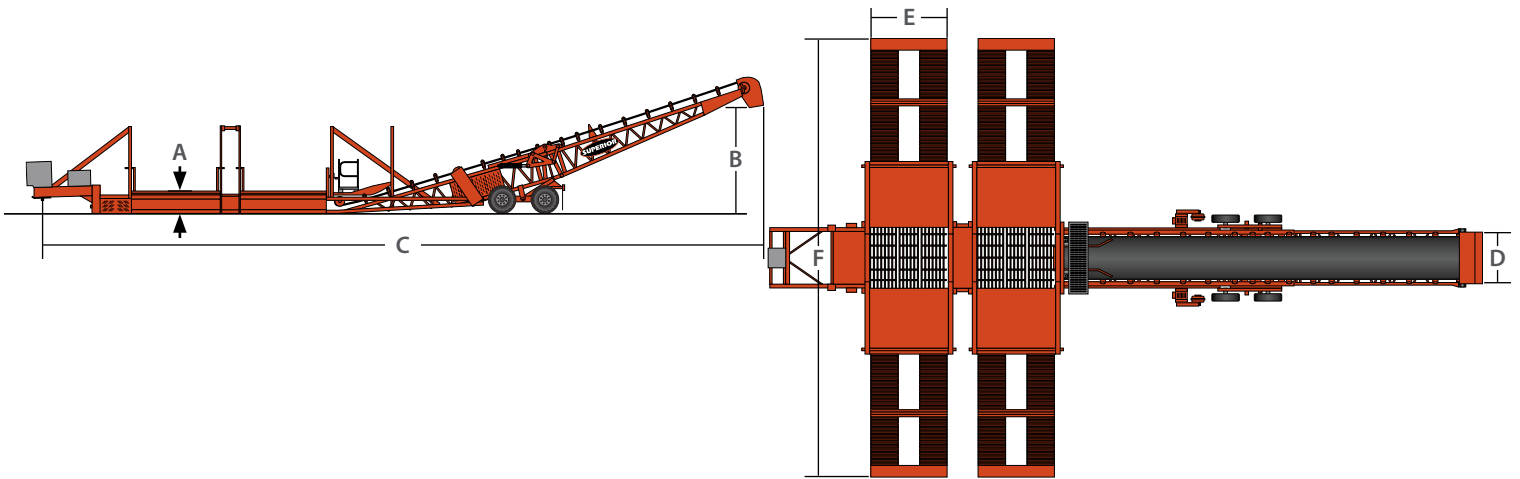

	72"*		72" Haul Truck*		72" Dual Lane*	
	Imperial	Metric	Imperial	Metric	Imperial	Metric
Capacity	1,500 stph	1,360 mtph	2,000 stph	1,814 mtph	1,500 stph	1,360 mtph
Maximum Material Size	4" Minus	Minus 101mm	8" Minus	Minus 203mm	4" Minus	Minus 101mm
Cycle Time in Minutes	2.5 / 30 Short Tons	2.5 / 27 Metric Tonnes	2.5 / 40 Short Tons	2.5 / 36 Metric Tonnes	2.5 / 30 Short Tons	2.5 / 27 Metric Tonnes
(A) Earth Ramp Height	25"	635mm	37"	939mm	25"	635mm
(B) Discharge Height	7'-9" - 12'-8"	2.3 - 3.8 m	7'-9" - 12'-8"	2.3 - 3.8 m	7'-9" - 12'-8"	2.3 - 3.8 m
(C) Conveyor Length	79'-4"	24.2 m	84'-3"	25.7 m	93'-1"	28.4 m
(D) Conveyor Width	7'-0"	2.1 m	7'-0"	2.1 m	7'-0"	2.1 m
(E) Load Ramp Width	10'-2"	3.1 m	15'-2"	4.6 m	10'-2"	3.1 m
(F) Load Ramp Length	24'-0"	7.3 m	24'-0"	7.3 m	56'-5"	17.2 m

TRAVEL SPECIFICATIONS

72-INCH BELT WIDTH, WITH FOLDING DISCHARGE CONVEYOR

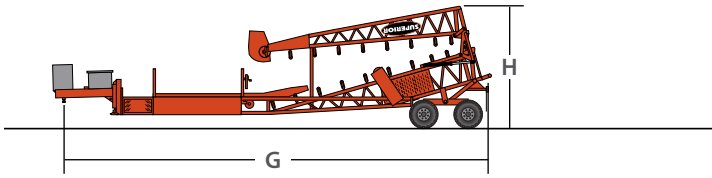

72-INCH BELT WIDTH, HAUL TRUCK, WITH FOLDING DISCHARGE CONVEYOR

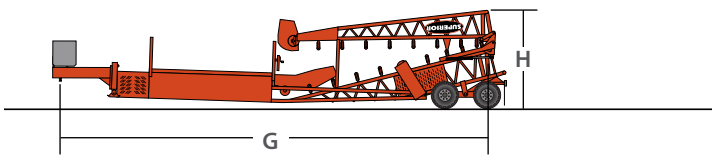

72-INCH BELT WIDTH, DUAL LANE WITH FOLDING DISCHARGE CONVEYOR

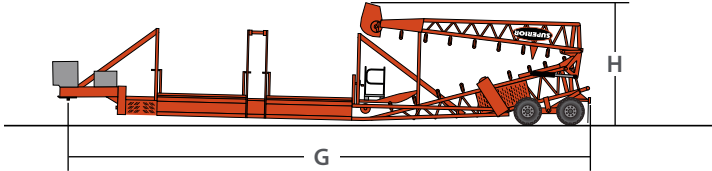

	72"*		72" Haul Truck*		72" Dual Lane*	
	Imperial	Metric	Imperial	Metric	Imperial	Metric
(G) Travel Length	52'-6"	16.0 m	57'-6"	17.5 m	66'-4"	20.2 m
(H) Travel Height	12'-6"	3.8 m	13'-7"	4.1 m	15'-11"	4.8 m
Travel Width	11'-9"	3.6 m	13'-10"	4.2 m	12'-3"	3.7 m
Weight at Axle	27,000 lb	12,245 kg	31,400 lb	14,250 kg	37,600 lb	17,050 kg
Weight at Axle*	29,200 lb	13,245 kg	N/A	N/A	44,000 lb	19,960 kg
Weight at Axle**	N/A	N/A	N/A	N/A	N/A	N/A
Weight at Kingpin	18,000 lb	8,165 kg	29,000 lb	13,150 kg	30,600 lb	13,880 kg
Weight at Kingpin*	24,200 lb	10,980 kg	N/A	N/A	39,800 lb	18,050 kg
Weight at Kingpin**	N/A	N/A	N/A	N/A	N/A	N/A
Axes	Tandem		Tandem		Tandem	

*Tri-Fold Ramps, **Hydraulic Tri-Fold Ramps



STATIONARY DRIVE OVER TRUCK UNLOADER

Rugged, Custom-Designed Unloading for Fixed Applications





RAZERLINK® MOBILE CONVEYORS

Highly Mobile Feed System Eliminate Double Handling of Material



TRACKS, DRIVE TIRES OR TOWABLE TIRES



FIXED, POWERFOLD OR TELESCOPING

Rock Face to Load Out™



SPECIFICATIONS

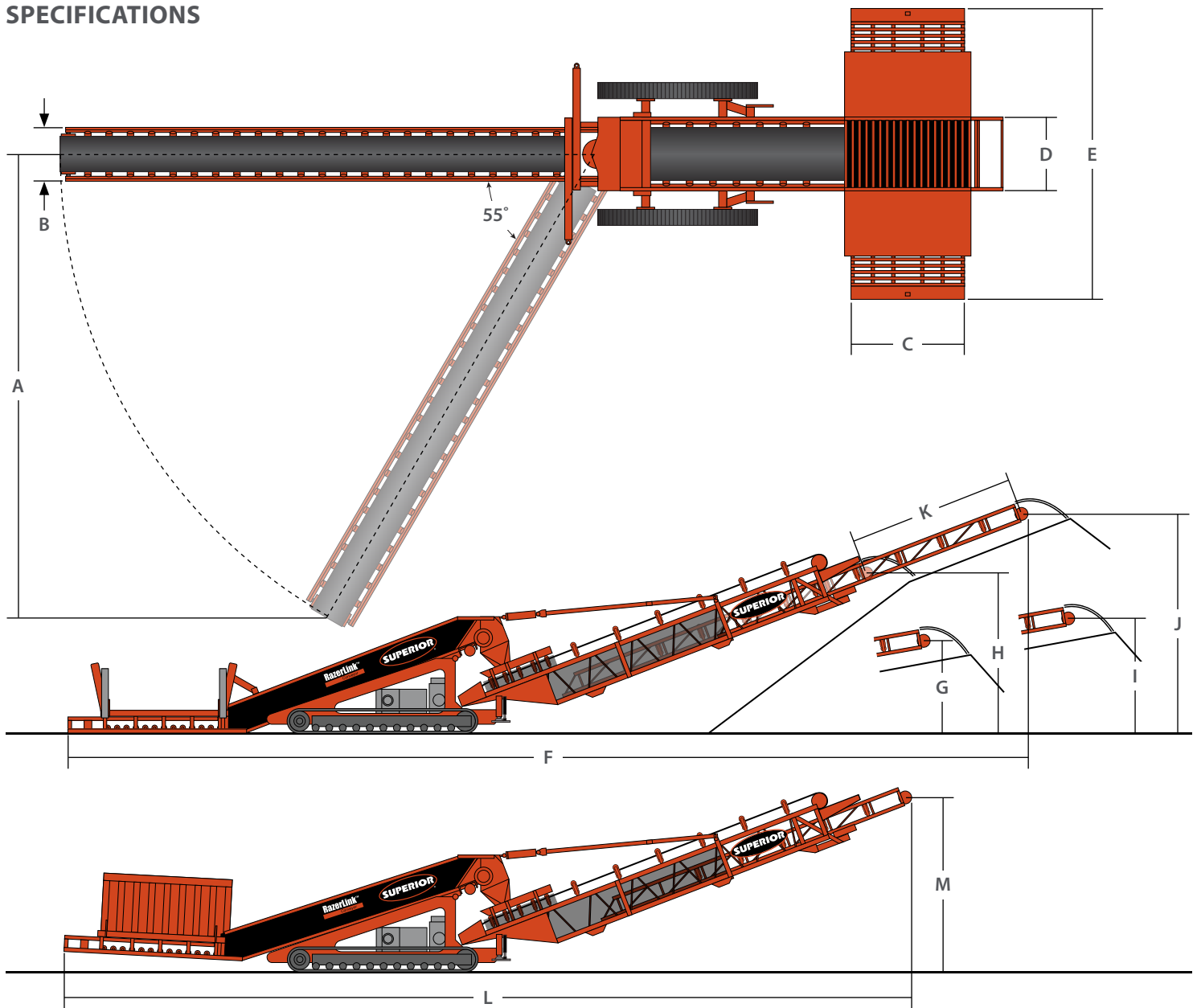

OPERATING SPECIFICATIONS	48"		72"	
	ft x in	m	ft x in	m
(A) Rotated Discharge Conveyor Distance	47'-2"	14.4	47'-2"	14.4
(B) Discharge Conveyor Width	6'-4"	2.0	7'-7"	2.3
(C) Load Ramp Width	11'-7"	3.5	11'-7"	3.5
(D) Main Conveyor Width	54"	1.3	66"	1.6
(E) Load Ramp Length	28'-8"	8.7	30'-4"	9.2
(F) Conveyor Length	94'-1"	28.7	94'-1"	28.7
(G) Lowered Height to Center of Pulley; Retracted	9'-0"	2.7	9'-0"	2.7
(H) Raised Height to Center of Pulley; Retracted	17'-8"	5.4	17'-8"	5.4
(I) Lowered Height to Center of Pulley; Extended	11'-2"	3.4	11'-2"	3.4
(J) Raised Height to Center of Pulley; Extended	22'-9"	6.9	22'-9"	6.9
(K) Discharge Conveyor Extension Length	18'-6"	5.6	18'-6"	5.6

CAPACITY SPECIFICATIONS	48"		72"	
	stph	mtph	stph	mtph
Tons Per Hour	1,000	907	1,500	1,360
	inch	mm	inch	mm

CAPACITY SPECIFICATIONS	48"		72"	
	ft x in	m	ft x in	m
Maximum Material Size	5"	127	5"	127

PIT TRAVEL SPECIFICATIONS	48"		72"	
	ft x in	m	ft x in	m
(L) Length to Head Pulley Center	81'-5"	24.8	81'-5"	24.8
(M) Height to Head Pulley Center	17'-1"	5.2	17'-1"	5.2



TUNNEL RECLAIM CONVEYOR

On Demand Access to Surge Pile for Continuous Feed to Plant



BENEFITS

- » Stress shedding design handles heavy loads
- » Operate fully engaged loaders and dozers across entire length
- » Maintain a continuous feed of material to processing plant
- » Modular design simplifies future modifications

SPECIFICATIONS

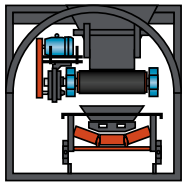
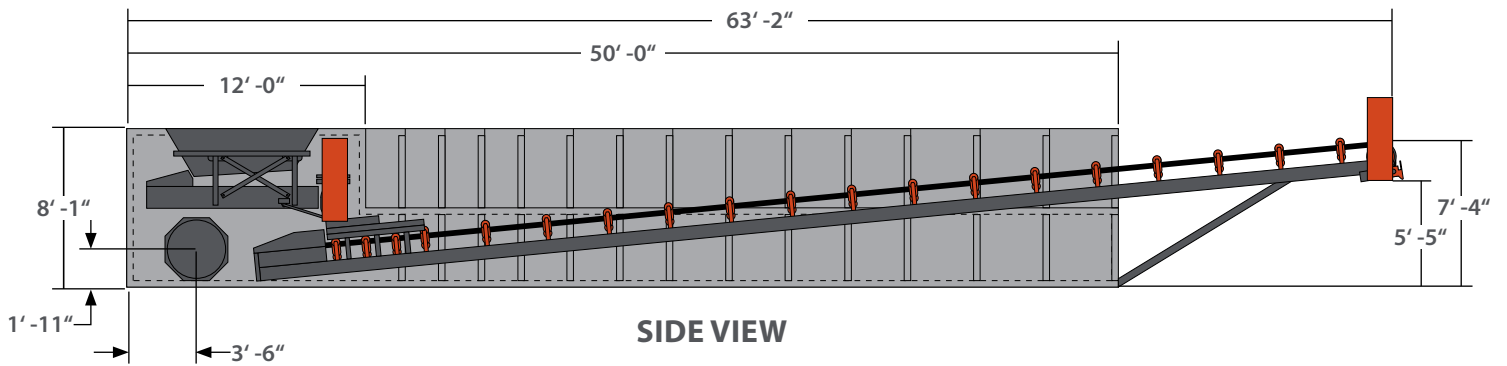

**1 WALKWAY
BOX-STYLE TUNNEL**

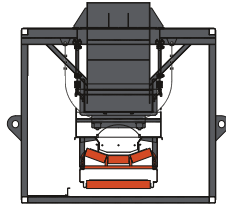

**2 WALKWAY
BOX-STYLE TUNNEL**

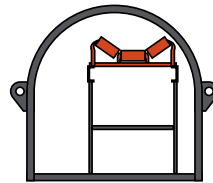

**1 WALKWAY
DOME-STYLE TUNNEL**

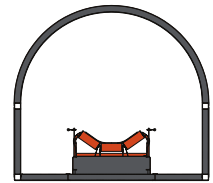

**2 WALKWAY
DOME-STYLE TUNNEL**

SPECIFICATIONS	Width		Height		Standard Lengths		Additional Increments		Walkways
	ft x in	m	ft x in	m	ft x in	m	ft x in	m	
8-foot Tunnel Reclaim	8'-0"	2.4	8'-0"	2.4	17'-0" or 51'-0"	5.1 or 15.5	34"	0.8	One
10-foot Tunnel Reclaim	10'-0"	3.0	9'-0"	2.7	17'-0" or 51'-0"	5.1 or 15.5	34"	0.8	One or Two
12-foot Tunnel Reclaim	12'-0"	3.6	9'-6"	2.8	17'-0" or 51'-0"	5.1 or 15.5	34"	0.8	One or Two

PHOTO GALLERY



ARCHED TUNNEL

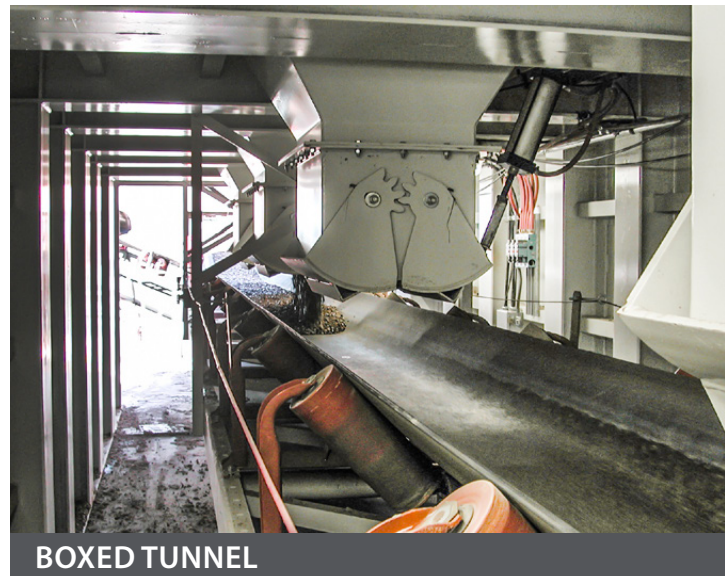

BOXED TUNNEL



DOZER TRAP

Feed Processing Plant Close to Mine Face



40" X 35' (1,016MM X 10M) TRACKED FEEDER

FEATURES

- » Structurally sound fabricated steel handles dozer weight
- » Custom widths and lengths depending on tonnage
- » Wheeled or track-mounted mobility options
- » Adjustable flow control
- » Power-matched Superior brand idlers, pulleys and accessories

COMPONENTS

EXCLUSIVE TO SUPERIOR INDUSTRIES

IDLERS



MOXIE®



URATHON®



NAVIGATOR®

ROLLS

HDPE sheds sticky material to prevent buildup on rolls for better belt tracking.

RETURN ROLLS

Urethane sheds sticky material to prevent buildup on rolls for better belt tracking.

RETURN TRAINER

Provides continuous belt alignment with no damaging side contact.

EXTERRA® BELT SCRAPERS



PRIMARY CLEANER

Standard primary blade has up to 40% more urethane than competitors. Set for life (SFL) upgrade option.



SECONDARY CLEANER

Segmented chunks with tungsten carbide tips for long life.



SFL DUAL CLEANER

Primary and secondary blade on one pole. Maintains proper tension for life of blade.



MINE DUTY

Extra bulky blade for long lasting cleaning in heaviest applications.

SUPERIOR'S APPLICATION-SPECIFIC IDLER SEALS



APPLICATIONS

Wash or dredge processes. Frequent washdowns.

BENEFITS

Special double contact seal defends bearing from moisture penetration.



APPLICATIONS

Crushing and screening producing dust with minimal fines.

BENEFITS

Oiled and contact seal protects bearing from dry particles and grit.

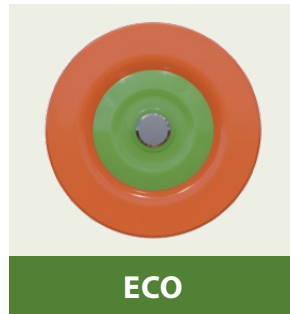

APPLICATIONS

Overland or long distance material handling sites.

BENEFITS

Seal reduces drag and roll resistance for less horsepower at startup/operation.



APPLICATIONS

Washed sand, fines removal or dredging. Most extreme conditions.

BENEFITS

Combination of design characteristics from wet and dry seals for ultimate bearing protection.

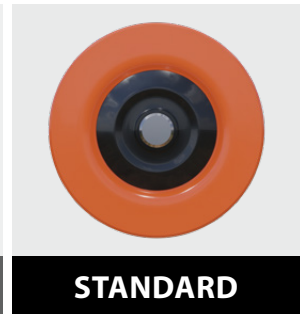

APPLICATIONS

Traditional material handling not described above. Typically 80-90% of applications.

BENEFITS

While testing our application specific models, we redesigned our standard for the best bearing protection yet.

For sales and service of Superior components, call (320)-589-2406

COMPONENTS

SUPERIOR PULLEYS DESIGNED FOR EVERY APPLICATION

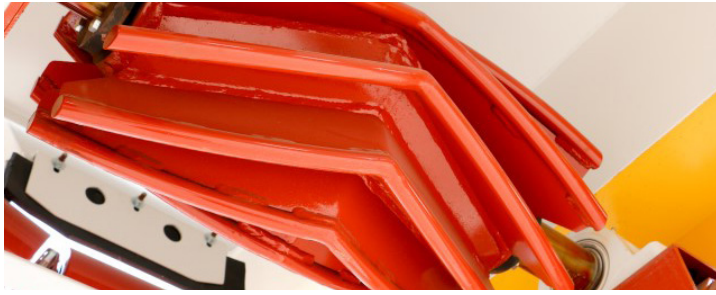

CHEVRON® PULLEY

V-shaped wings reject fugitive material at tail, which extends life of belts.

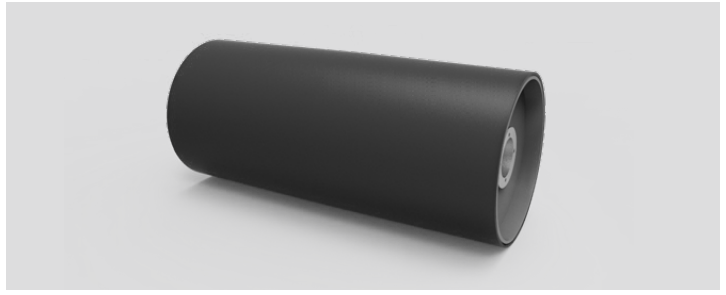

PRIME™ MINE DUTY PULLEY

End disc machined from solid steel, which eliminates welded hub.

	CEMA DUTY		MINE DUTY		SUPER DUTY	
			Prime™ Mine Duty	Mine Duty		
Drum Pulleys						
Belt Style	Fabric		Fabric	Fabric	Fabric	
Belt Burden	No Load		Full-Load	Full-Load	Full-Load	
Starts and Stops	Infrequent		Frequent	Frequent	Frequent	
Belt/Feed Characteristics	Uniformly Loaded		Non-Uniformly Loaded	Non-Uniformly Loaded	Non-Uniformly Loaded	

	CEMA DUTY		MINE DUTY		SUPER DUTY	
	Standard Wing	Chevron Wing	Standard Wing	Chevron Wing	Standard Wing	Chevron Wing
Wing Pulleys						
Belt Style	Fabric	Fabric	Fabric	Fabric	Fabric	Fabric
Belt Burden	No Load	Full-Load	Full-Load	Full-Load	Full-Load	Full-Load
Starts and Stops	Infrequent	Frequent	Frequent	Frequent	Frequent	Frequent
Belt/Feed Characteristics	Uniformly Loaded	Non-Uniformly Loaded	Non-Uniformly Loaded	Non-Uniformly Loaded	Non-Uniformly Loaded	Non-Uniformly Loaded
Wing Bar Thickness	Standard: 1/4" x 1-1/2" Available: 3/8" and 5/8" x 1-1/2", 1" x 2" Round: 3/4", and 1"		Standard: 5/8" x 1-1/2" Available: 3/4" x 2", 1" x 1/2"; 3/4" Round: 1" and 1-1/2"		Standard: 3/4" x 2" Round: 1" and 1-1/2"	

For sales and service of Superior components, call (320)-589-2406





ROCK FACE TO
LOAD OUTTM

superior-ind.com

2023-01SPHB1024EN-19