

The SALA series of

Vertical sump pumps



Most
reliable on
the market



Rubber lined & hard metal

Vertical sump pumps

All Metso Sump Pumps are designed specifically for abrasive slurries and feature a robust design with ease of maintenance.

Developed from the old SALA sump pump, VASA G model, the Metso type VS vertical sump is the next generation heavy duty sump pump.

Pump designation

VS 100 L120 O3S

- Spray hole casing
- 3 vane semi-open impeller
- Frame length (cm)
- Outlet size (mm)
- Pump Range



VS100 L120 O3S

Simple installation

With small sump pumps it is possible to hang the pump in the sump by the lifting bracket provided. Larger units are normally bolted to a permanent base plate. Pump bearings are located in a housing above the base plate for accessibility and protection. All pumps can run dry intermittently. Pumps with metal pump parts can run dry for an unlimited length of time.

Special designs giving extended length, with the bearings below the base plate, are available on request.

Like its predecessor, the VS sump pump is one of the strongest, toughest and most reliable available on the market. For this reason the VS is preferred throughout the world by most heavy industries.

Pump designation

VSHM150 L120 C5

- 5 vane closed impeller
- Frame length (cm)
- HM150 is the horizontal pump wear parts (150 is the inlet size, mm)
- Pump Range



VSHM150 L120 C5

Cantilever design

The heavy duty pump shaft is of cantilever design, hanging below the bearing housing. There are no submerged bearings, stuffing box or shaft seals. This design ensures minimum maintenance and eliminates the need for water flushing.

The pump shaft is mounted in grease lubricated roller bearings. Impeller clearance is maintained by external axial adjustment of the shaft/bearing assembly.

Bearings have double seal protection against contamination.

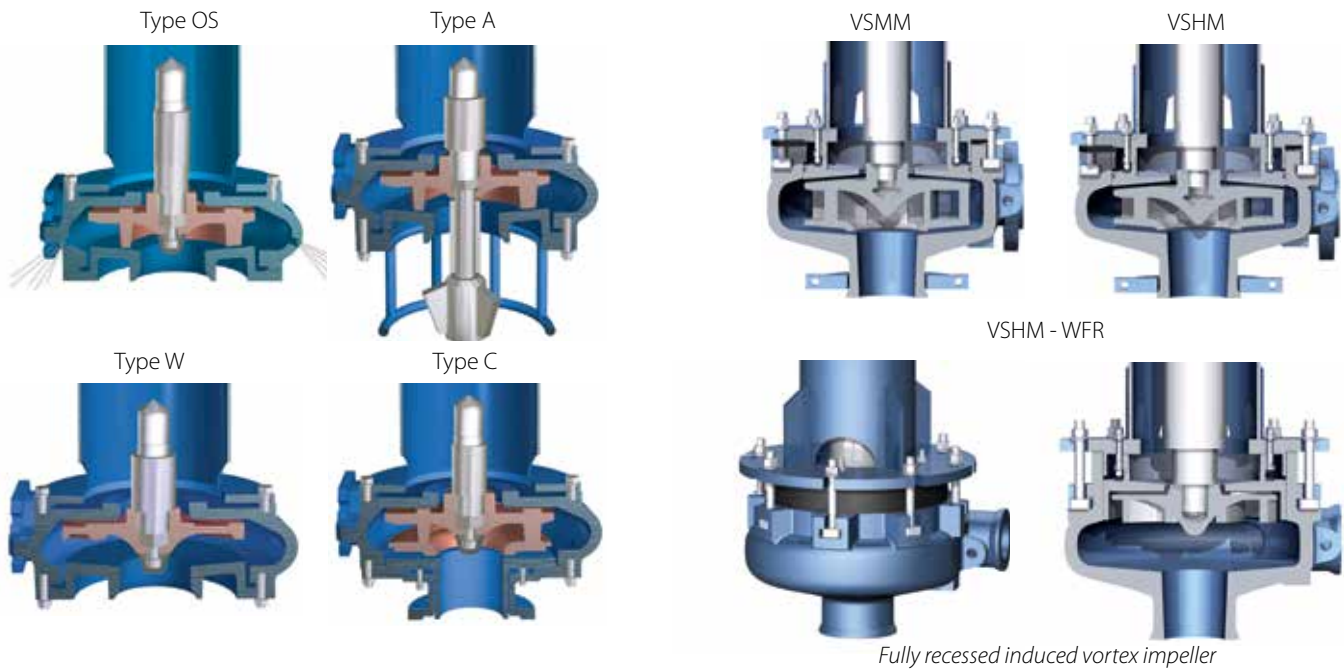

Details of design features

Impeller and agitation options VS

Four different impeller and two agitation options are available for optimum performance.

Type O – The semi-open impeller provides better solids handling than the closed impeller design and is less sensitive to air blocking on intermittent operation.

Type W – Vortex induced flow impeller for clogless pumping of long fibrous or coarse solids. It can be fitted into a casing with or without spray holes.

Large clearance between casing and impeller – well suited for pumping fibrous slurries (paper stock, wood chips, municipal sludge, etc.), aerated or frothy liquids (vortex impeller will not be air blocked) and any application where the pump is required to pass the occasional large solids.

Type WFR – We have developed a fully recessed induced vortex impeller for the VSHM pumps. This is specifically designed for carbon transfer in gold leaching processes because it provides the lowest possible attrition of the pumped active carbon particles.

Type C – Closed impeller for higher heads and efficiencies. Can not be combined with type S, casings with spray holes.

Type A – Semi-open impeller and robust extended shaft with a slurry agitator. This design is best suited for coarse rapid settling solids and dredging type applications.

Type S – Pump casing with spray holes. The spray holes direct some of the slurry towards the sump bottom, thereby agitating settled solids. Available from VS50 to VS200.

Wet end

The “wet end” parts have large material sections for extra long wear life and are designed for the toughest of applications. Single volute and generous solids passage through the pump ensure safe and clogless operation.

The “wet end” assembly is suspended from a tubular column below the bearing housing.

Materials

Standard pumps are supplied with parts in wear resistant natural rubber or High Chrome white iron alloy, with a nominal hardness of 600 BHN.

Other wear part materials available include elastomers in synthetic rubbers and polyurethane and metals such as 316 stainless steel and CD4MCu.

Parts in different materials are fully interchangeable and can be combined for optimum life.

The VSH and VSM pumps are a new combination of our classic VS sump pumps and our Orion series horizontal pump wet ends.

This provides a major advantage to the customer: the same wet end parts are used for both horizontal slurry pumps and sump pumps, thus reducing parts inventory and simplifying maintenance. It does also make it possible to generate a higher TDH, pump head.

Typical sump pump applications

- Floor sumps in process plants
- Mill scale pumping in steel work
- Pumping of machine tool cuttings
- Wood chips pumping

Drive

Pumps can be supplied with a V-belt drive, motor and drive guard. The motor is mounted vertically, on an adjustable motor plate fitted beside the bearing housing.

Motor Size

Motor size and V-belt drive vary with the pump application. Minimum data required for an approximate pump, speed and drive motor selection are:

- Slurry flow rate
- Slurry density
- Total discharge head

Summary of design features

- Simple installation
- Cantilever design without submerged bearings or shaft seal
- Bearing assembly with double protection sealing arrangement to prevent bearing contamination
- Materials used are the very best available, providing both excellent wear properties and corrosion resistance
- Wear parts are available in a variety of different materials and fully interchangeable
- Range of impeller and casing options

We have developed a fully recessed induced vortex impeller for the VSHM pumps. This is specifically designed for carbon transfer in gold leaching processes because it provides the lowest possible attrition of the pumped active carbon particles.



VSHM 100 E250 C5 is a special design type with "E" extended shaft



Acid proof version with all wetted parts fully covered with natural rubber or chlorobutyl.



VSHM 250 L150
Direct drive,
90 kW, 8-pole motor

Selection of pump size and pump dimensions VS vertical sump pump range

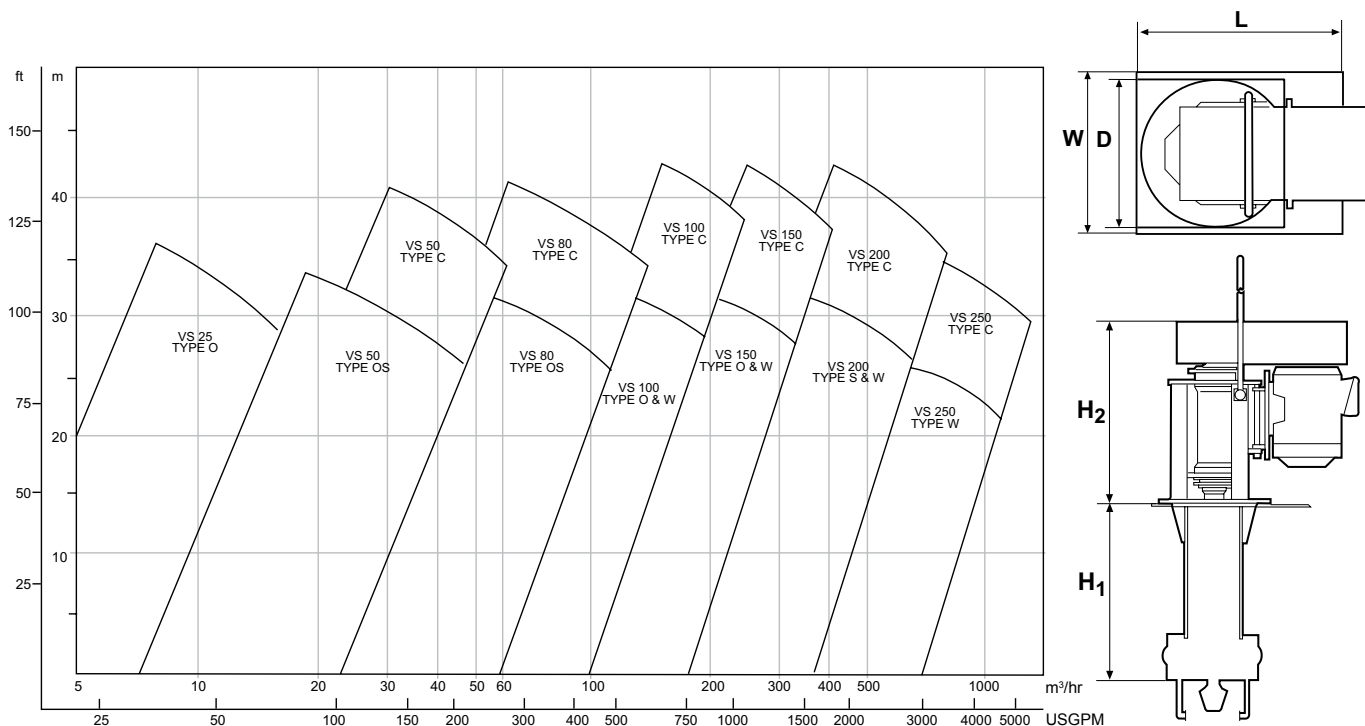

| Pump Size | Outlet* inch | H ₁ | | H ₂ | | D** | | L Opt. base plate | | W | | Weight *** | | Weight Opt. base plate | |
|-----------|--------------|----------------|------|----------------|------|-------|--------------------------------|-------------------|--------------------------------|-------|--------------------------------|------------|-------|------------------------|-----|
| | | mm | inch | mm | inch | mm | inch | mm | inch | mm | inch | kg | lb | kg | lb |
| VS25 | 1 | 800 | 32 | 585 | 23 | Ø 400 | 15 ³ / ₄ | 450 | 17 ³ / ₄ | 450 | 17 ³ / ₄ | 130 | 287 | 11 | 24 |
| VS25 | 1 | 1 200 | 48 | 865 | 34 | Ø 530 | 20 ³ / ₄ | 600 | 23 ¹ / ₂ | 600 | 23 ¹ / ₂ | 350 | 772 | 27 | 60 |
| VS25 | 1 | 1 500 | 60 | 865 | 34 | Ø 530 | 20 ³ / ₄ | 600 | 23 ¹ / ₂ | 600 | 23 ¹ / ₂ | 375 | 827 | 27 | 60 |
| VS25 | 1 | 1 800 | 72 | 865 | 34 | Ø 530 | 20 ³ / ₄ | 600 | 23 ¹ / ₂ | 600 | 23 ¹ / ₂ | 395 | 871 | 27 | 60 |
| VS50 | • 2 | 800 | 32 | 585 | 23 | Ø 400 | 15 ³ / ₄ | 600 | 23 ¹ / ₂ | 600 | 23 ¹ / ₂ | 220 | 485 | 30 | 66 |
| VS50 | • 2 | 1 200 | 48 | 865 | 34 | Ø 530 | 20 ³ / ₄ | 600 | 23 ¹ / ₂ | 600 | 23 ¹ / ₂ | 480 | 1 058 | 27 | 60 |
| VS50 | • 2 | 1 500 | 60 | 865 | 34 | Ø 530 | 20 ³ / ₄ | 600 | 23 ¹ / ₂ | 600 | 23 ¹ / ₂ | 510 | 1 124 | 27 | 60 |
| VS50 | • 2 | 1 800 | 72 | 975 | 38 | Ø 565 | 22 ¹ / ₄ | 600 | 23 ¹ / ₂ | 600 | 23 ¹ / ₂ | 540 | 1 190 | 27 | 60 |
| VS80 | • 3 | 800 | 32 | 870 | 34 | Ø 530 | 20 ³ / ₄ | 600 | 23 ¹ / ₂ | 600 | 23 ¹ / ₂ | 415 | 915 | 31 | 68 |
| VS80 | • 3 | 1 200 | 48 | 975 | 38 | Ø 565 | 22 ¹ / ₄ | 600 | 23 ¹ / ₂ | 600 | 23 ¹ / ₂ | 530 | 1 168 | 31 | 68 |
| VS80 | • 3 | 1 500 | 60 | 975 | 38 | Ø 565 | 22 ¹ / ₄ | 600 | 23 ¹ / ₂ | 600 | 23 ¹ / ₂ | 565 | 1 245 | 31 | 68 |
| VS80 | • 3 | 1 800 | 72 | 975 | 38 | Ø 565 | 22 ¹ / ₄ | 600 | 23 ¹ / ₂ | 600 | 23 ¹ / ₂ | 600 | 1 322 | 31 | 68 |
| VS100 | • 4 | 800 | 32 | 850 | 33 | Ø 530 | 20 ³ / ₄ | 750 | 29 ¹ / ₂ | 600 | 23 ¹ / ₂ | 435 | 959 | 45 | 99 |
| VS100 | • 4 | 1 200 | 48 | 960 | 37 | Ø 565 | 22 ¹ / ₄ | 750 | 29 ¹ / ₂ | 600 | 23 ¹ / ₂ | 550 | 1 212 | 45 | 99 |
| VS100 | • 4 | 1 500 | 60 | 960 | 37 | Ø 565 | 22 ¹ / ₄ | 750 | 29 ¹ / ₂ | 600 | 23 ¹ / ₂ | 585 | 1 289 | 45 | 99 |
| VS100 | • 4 | 1 800 | 72 | 960 | 37 | Ø 565 | 22 ¹ / ₄ | 750 | 29 ¹ / ₂ | 600 | 23 ¹ / ₂ | 620 | 1 366 | 45 | 99 |
| VS150 | • 6 | 1 200 | 48 | 965 | 38 | Ø 565 | 22 ¹ / ₄ | 900 | 35 ¹ / ₂ | 750 | 29 ¹ / ₂ | 645 | 1 422 | 80 | 176 |
| VS150 | • 6 | 1 500 | 60 | 1 285 | 50 | □ 800 | 31 ¹ / ₂ | 1 200 | 47 ¹ / ₂ | 900 | 35 ¹ / ₂ | 1 370 | 3 019 | 140 | 309 |
| VS150 | • 6 | 1 800 | 72 | 1 285 | 50 | □ 800 | 31 ¹ / ₂ | 1 200 | 47 ¹ / ₂ | 900 | 35 ¹ / ₂ | 1 425 | 3 141 | 140 | 309 |
| VS200 | • 8 | 1 200 | 48 | 1 285 | 50 | □ 800 | 31 ¹ / ₂ | 1 200 | 47 ¹ / ₂ | 900 | 35 ¹ / ₂ | 1 610 | 3 548 | 172 | 379 |
| VS200 | • 8 | 1 500 | 60 | 1 285 | 50 | □ 800 | 31 ¹ / ₂ | 1 200 | 47 ¹ / ₂ | 900 | 35 ¹ / ₂ | 1 660 | 3 659 | 172 | 37 |
| VS200 | • 8 | 1 800 | 72 | 1 285 | 50 | □ 800 | 31 ¹ / ₂ | 1 200 | 47 ¹ / ₂ | 900 | 35 ¹ / ₂ | 1 710 | 3 769 | 172 | 379 |
| VS250 | 10 | 1 500 | 60 | 1 420 | 56 | □ 800 | 31 ¹ / ₂ | 1 360 | 53 ¹ / ₂ | 1 220 | 48 | 2 200 | 4 850 | 265 | 584 |
| VS250 | 10 | 1 800 | 72 | 1 420 | 56 | □ 800 | 31 ¹ / ₂ | 1 360 | 53 ¹ / ₂ | 1 220 | 48 | 2 280 | 5 027 | 265 | 584 |

*VS25 1 : VS = Vertical Sump; 25 = outlet mm; 1 = outlet inch

** D Ø or □ is bearing frame base plate. Larger optional base plate or mounting plate incl. discharge pipe also available.

*** Weight figures are for metal parts type O & W. For rubber parts reduce weight by approx. 10%.

• These pumps are available in acid proof version with all wetted parts fully covered with natural rubber or chloroprene.

Selection of pump size and pump dimensions VSH, VSM vertical sump pump range

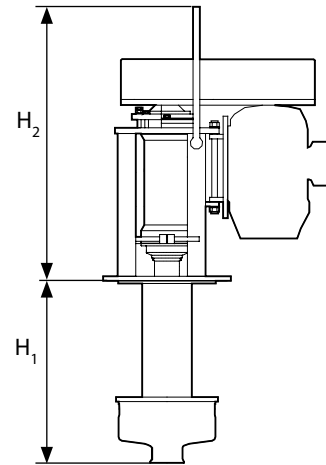
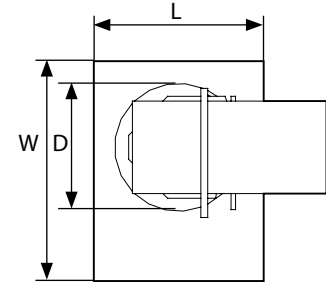
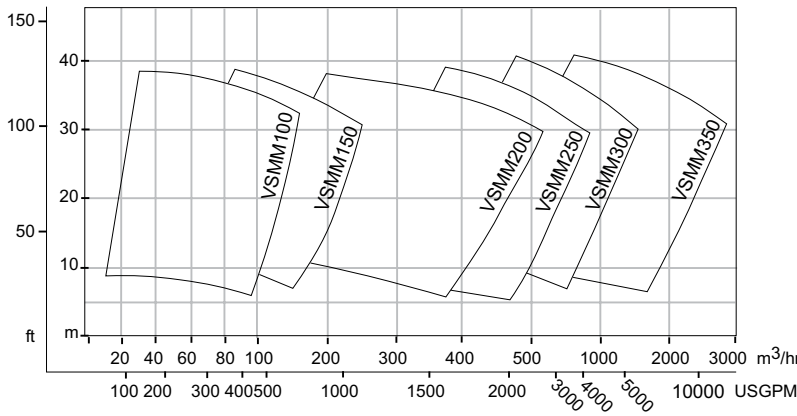
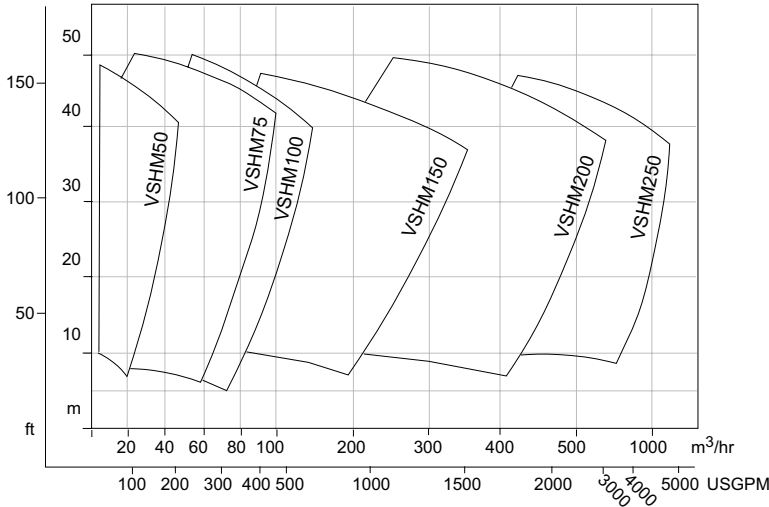

| Pump Size | Outlet | | H ₂ | | D* | | L Opt. base plate | | W | | Weight ** | |
|-----------|--------|------|----------------|------|-------|------|-------------------|------|------|------|----------------------|----------------|
| | mm | inch | mm | inch | mm | inch | mm | inch | mm | inch | kg | lb |
| VSHM50 ● | 32 | 1,25 | 870 | 34 | ∅ 530 | 20 ¾ | 600 | 23 ½ | 600 | 23 ½ | 390/405/420 | 860/893/926 |
| VSHR50 | 32 | 1,25 | 870 | 34 | ∅ 530 | 20 ¾ | 600 | 23 ½ | 600 | 23 ½ | 380/395/410 | 838/871/904 |
| VSHM75 ● | 50 | 2 | 870 | 34 | ∅ 530 | 20 ¾ | 600 | 23 ½ | 600 | 23 ½ | (L120) 415 | 915 |
| VSHR75 | 50 | 2 | 870 | 34 | ∅ 530 | 20 ¾ | 600 | 23 ½ | 600 | 23 ½ | (L150 / 180) 530/565 | 1168/1245 |
| VSHM100 ● | 75 | 3 | 980 | 38 | ∅ 565 | 22 ¼ | 750 | 29 ½ | 600 | 23 ½ | 535/565/605 | 1180/1246/1334 |
| VSHR100 | 75 | 3 | 980 | 38 | ∅ 565 | 22 ¼ | 750 | 29 ½ | 600 | 23 ½ | 555/585/625 | 1224/1290/1378 |
| VSHM150 ● | 100 | 4 | 1280 | 50 | □ 800 | 31 ½ | 1200 | 47 ¼ | 900 | 35 ½ | 1314/1366/1418 | 2897/3012/3127 |
| VSHR150 | 100 | 4 | 1280 | 50 | □ 800 | 31 ½ | 1200 | 47 ¼ | 900 | 35 ½ | 1405/1460/1515 | 3098/3219/3340 |
| VSHM200 | 150 | 8 | 1280 | 50 | □ 800 | 31 ½ | 1200 | 47 ¼ | 900 | 35 ½ | 1650/1710/1770 | 3638/3770/3903 |
| VSHR200 | 150 | 8 | 1280 | 50 | □ 800 | 31 ½ | 1200 | 47 ¼ | 900 | 35 ½ | 1680/1740/1796 | 3704/3836/3960 |
| VSHM250 | 200 | 10 | 1420 | 56 | □ 800 | 31 ½ | 1360 | 53 ½ | 1220 | 48 | 2310/2400/2480 | 5093/5291/5468 |
| VSHR250 | 200 | 10 | 1420 | 56 | □ 800 | 31 ½ | 1360 | 53 ½ | 1220 | 48 | 2365/2455/2535 | 5214/5413/5589 |
| VSMM100 ● | 75 | 4 | 870 | 34 | ∅ 530 | 20 ¾ | 600 | 23 ½ | 600 | 23 ½ | 430/465/500 | 948/1025/1103 |
| VSMM150 ● | 100 | 6 | 980 | 38 | ∅ 565 | 22 ¼ | 750 | 29 ½ | 600 | 23 ½ | 560/590/630 | 1235/1301/1389 |
| VSMM200 ● | 150 | 8 | 1280 | 50 | □ 800 | 31 ½ | 1200 | 47 ¼ | 900 | 35 ½ | 1390/1445/1500 | 3065/3186/3307 |
| VSMM250 | 200 | 10 | 1280 | 50 | □ 800 | 31 ½ | 1200 | 47 ¼ | 900 | 35 ½ | 1720/1780/1840 | 3792/3925/4057 |
| VSMM300 | 200 | 12 | 1420 | 56 | □ 800 | 31 ½ | 1360 | 53 ½ | 1220 | 48 | 2490/2570/2650 | 5490/5666/5843 |
| VSMM350 | 300 | 14 | 1420 | 56 | □ 800 | 31 ½ | 1360 | 53 ½ | 1220 | 48 | - /2745/2825 | - /6052/6228 |

Frame length (H₁) is available in 120, 150, 180 cm (48, 60, 72 inch) except VSMM350 which is available in 150, 180 cm (60, 72 inch).

* D ∅ or □ is bearing frame base plate. Larger optional base plate or mounting plate incl. discharge pipe also available.

** Weight figures are for metal parts, and for different frame lengths (L120 / L150 / L180).

● These pumps are available with the fully recessed induced vortex impeller.

- **Metso Minerals (Sweden) AB**
Norrängsgatan 2, SE-733 38 Sala, Sweden, Phone: +46 224 570 00, Fax: +46 224 169 50
- **Metso Minerals Industries Inc.**
4820 Centennial Blvd, Suite 115, Colorado Springs, Co 80919-3351, USA, Phone: +1 719 471 3443, Fax: +1 719 471 4469
- **Metso Minerals Industries Inc.**
P.O. Box 96, Birmingham, AL 35201, USA, Phone: +1 205 599 6600, Fax: +1 205 599 6623
- **Metso Minerals (South Africa) (Pty) Ltd.**
Private Bag X2006, Isando, Johannesburg, 1600, South Africa, Phone: +27 11 961 4000, Fax: +27 11 397 2050
- **Metso Minerals (Australia) Ltd.**
Level 2, 1110 Hay Street, West Perth, WA 6005, Australia, Phone: +61 8 9420 5555, Fax: +61 8 9320 2500
- **Metso Minerals (India) Pvt Ltd**
1th floor, DLF Building No. 10, Tower A, DLF Cyber City, Phase - III, Gurgaon - 122 002, India, Phone: +91 124 235 1541, Fax: +91 124 235 1601
- **Metso Perú S.A.**
Calle 5 Nro. 144, Urb. Industrial Vulcano, Ate, Lima 03, Peru, Phone: +51 1 313 4366, Fax: +51 1 349 0913
- **Metso Minerals (Chile) S.A.**
Av. Los Conquistadores 2758, Piso 3, Providencia, Santiago, Chile, Phone: +56 2 370 2000, Fax: +56 2 370 2039
- **Metso Brasil Indústria e Comércio Ltda.**
Av. Independência, 2500 Éden, 18087-101 Sorocaba-SP - Brazil, Phone: +55 15 2102 1709



www.metso.com
E-mail: minerals.info@metso.com
Pumps information at
www.metso.com/pumps