

Metso

Crushing and screening solutions



Making the big
difference to
our customers

Contents

Introduction	3
Jaw crushers	
Nordberg® C Series™	4
Metso rock breakers	16
Impact crushers	
Nordberg® NP Series™	20
Cone crushers	
Nordberg® HP Series™	30
Nordberg® GP Series™	40
Vertical shaft impact crushers	
Barmac® B Series™	52
Metso IC™ crusher automation	62
Vibrating equipment	64
Metso screens	
Metso PREMIER CVB™ inclined screens	71
Metso PREMIER ES™ horizontal screens	73
Metso PREMIER TS™ multi-slope screens	75
Optimize your screen	76
Technical specifications	77
Metso feeders	
Metso VG™ primary scalpers	79
Metso VF™ grizzly feeders	81
Compatibility chart	83
Metso's application expertise	
Bruno™ process simulation tool	86
Application examples	88
Services	92

Right where you need us We supply competitiveness

At Metso, we know that the only real measure of our worth is in the results we deliver to our customers. Our expertise is rooted in more than a century of experience that today provides our customers with an unparalleled knowledge base, rock-solid financial resources, plus the engineering know-how, innovative technologies and worldwide locations to ensure that your crushing and screening operations will profit.

Metso's products are built to last. Our crushers and screens are highly engineered and precisely tested to ensure that they run and deliver 24 hours a day, 365 days a year. Metso's experience and competence in crushing and screening technology ensures that we provide equipment that is the best in the world. The use of premium-quality components ensures that your Metso equipment runs at high performance, cost efficiently and safely.

With Metso equipment, you can be sure that your operations – and profit – stay up and running. Uninterrupted.



Nordberg®
C Series™

Nordberg® C Series™

Why choose Metso's jaw crusher?

Reliability

- Pinned and bolted, non-welded frame construction
- Outstanding fatigue strength
- Excellence in casting engineering
- Premium-quality components

Productivity

- Excellent material intake capability
- Steep cavity cross section for excellent bite
- Aggressive pitman motion for efficient compression
- Reliability, high availability

Easy installation

- Compact crusher module
- Easy to install in place of an existing crusher
- Possible to ship to the site in pieces (for example, in case of underground installation)

Safety

- Lifting tools for jaw dies, cheek plates and toggle plate as standard
- Optional flywheel and drive guards
- Optional maintenance platform
- Safe, quick and easy setting adjustment system
- Metso IC™ crusher automation



Jaw crushers Nordberg® C Series™

Nordberg® C Series™ jaw crushers are engineered for the toughest feed materials. They are proven to be reliable and productive in thousands of real mining, quarrying, recycling and industrial applications. You can rely on the Nordberg C Series jaw crusher as the backbone of your process.

Uncompromised reliability and productivity

The reliability of Nordberg C Series jaw crushers is based on a revolutionary pinned and bolted, non-welded frame construction. This design provides excellent fatigue strength even in toughest quarrying or mining applications.

Metso's foundry expertise enables continuous steel casting development to ensure the best casting designs and quality in terms of strength and fatigue life. High level of engineering combined with top-of-the-line commercial components, such as spherical roller bearings, ensure the reliability that Nordberg C Series jaw crushers are known for.

Nordberg C Series jaw crushers are the most productive and cost-efficient jaw crushers for any primary crushing application. C Series jaw crushers were originally developed to crush the hardest ores and rocks so they perform extremely well also in less demanding applications, such as soft rock, recycling and slag.

Benefits

- Reliability
- Productivity
- Easy installation
- Safety

Nordberg® C Series™

Jaw crushers

Nordberg C Series jaw crushers are engineered to deliver maximum productivity at the lowest operating costs. Reliability combined with great performance, low operating costs and easy maintenance ensure the best result in a real primary crushing application.

Excellent material intake capacity

Feed opening depth, which typically defines the top feed size, is well balanced with the width and height of the crusher. A good feed opening depth enables excellent material intake capacity and ensures that the rocks enter the cavity without restrictions.

Excellent bite in the cavity

The steep nip angle, the angle between the movable and fixed jaw dies, ensures good bite and good material flow down in the cavity. On top of great performance, a good nip angle also reduces wear on the jaw dies -- and that has a direct impact on operating costs.

High production and reduction

Nordberg C Series jaw crushers are well known for the aggressive motion of the pitman and long stroke in the bottom of the cavity. The stroke is amplified from the top to the bottom, which means that the stroke is always longest in the bottom of the cavity. This boosts the capacity as well as the reduction ratio, resulting in high production and better end-product gradation.

Easy to maintain

Areas where any wear is anticipated are engineered to be easy to replace or protected by sacrificial wear items. This ensures that maintenance of C Series jaw crushers is easy and cost efficient over the long lifetime of the crusher. These designs protect the most expensive main components from wear and shorten maintenance time. And a shorter maintenance time means higher uptime.

Benefits of Nordberg C Series

- High production
- High reduction ratio
- Easy maintenance
- High uptime

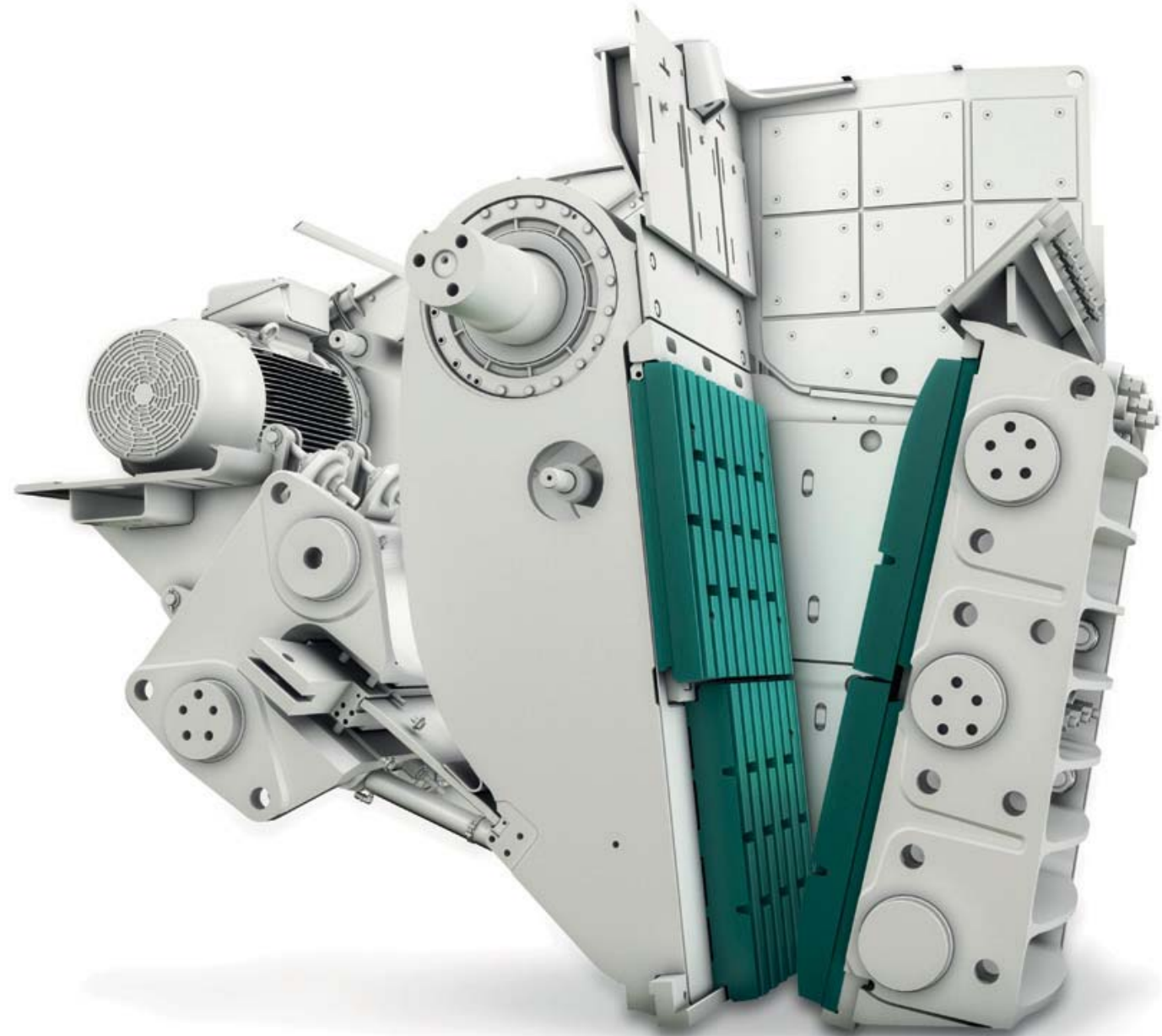

Nordberg® C Series™

Significant space, time and cost savings in installation

Nordberg C Series jaw crushers offer multiple benefits that save space, time and money. This makes the Nordberg C Series the most economical choice in both greenfield and brownfield applications. The modular structure is ideally suited to open-pit installations and adds even more value when installed underground.

Installation made easy

Nordberg C Series jaw crushers are easily installed into either new plants or to replace older jaw crushers to extend plant lifetime and boost production. The modular concept makes the C Series jaw crushers easy to install. The crusher can be installed as one compact module that includes all the necessary auxiliaries around the crusher itself. The crusher can be installed within a few days, minimizing on-site engineering and fabrication. Ultimately, this leads to a significant savings in time and installation costs.

Wide range of options

C Series jaw crushers can be customized with options for any application. Safe flywheel and drive guards protect operators from moving objects. An optional integrated motor base allows installation of the crusher drive motor directly to the back of the crusher. The motor moves in sync with the crusher so the V-belt life is enhanced and alignment and tensioning are always perfect. An optional feed chute is engineered for uninterrupted material flow from the feeder into the crusher.

Favored in underground mining

Nordberg C Series jaw crushers are very popular in underground mining applications. The possibility to dismantle the jaw crushers for transport makes them especially easy to use in underground installations. Moving the dismantled components into the tunnel requires less space in the tunnel and shaft and less heavy lifting. The crusher can be installed and commissioned in its final destination within a few days. These factors make the C Series the most favored jaw crushers for underground operations.

Easy installation

- Modular structure
- Wide selection of options
- Savings in transport, installation and on-site engineering costs

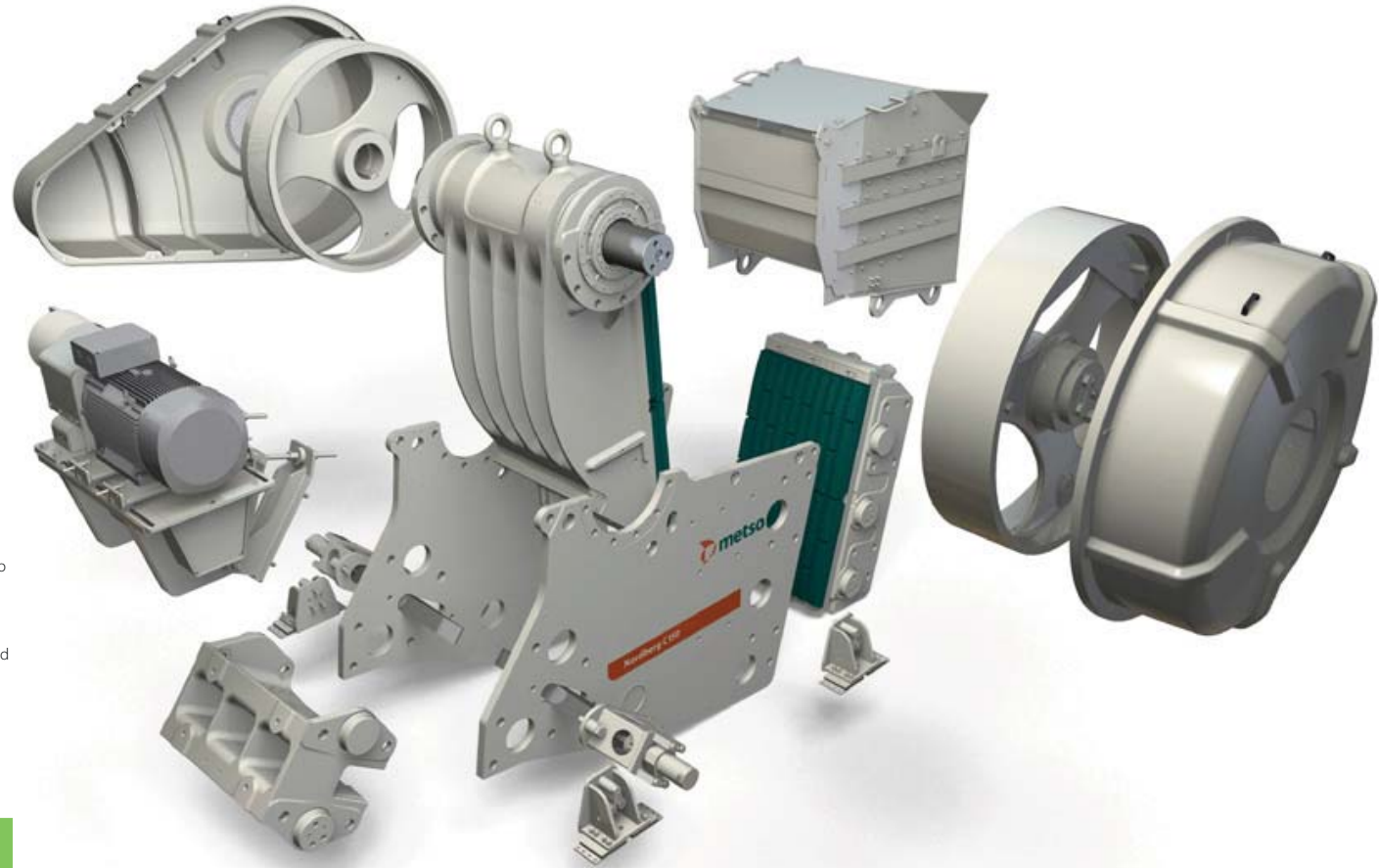

All Nordberg® C Series™ jaw crushers are based on a revolutionary modular, non-welded frame construction.

Nordberg® C Series™

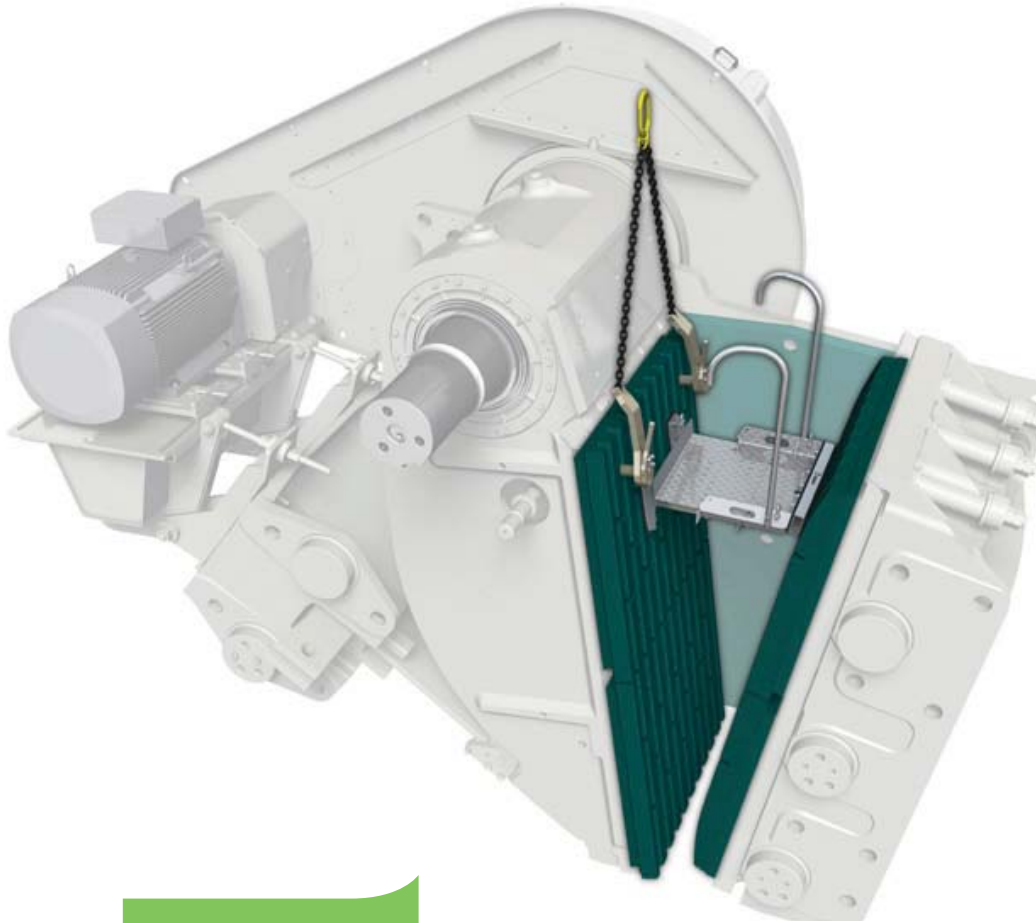

Nordberg® C Series™ jaw crushers are delivered with lifting tools for jaw dies and cheek plates.

In addition, the new Maintenance platform makes wear part change safe and easy.

	C80™	C100™	C96™	C106™	C116™	C120™	C130™	C150™	C160™	C200™
Technical specifications										
Power	75 kW (100 hp)	110 kW (150 hp)	90 kW (125 hp)	110 kW (150 hp)	132 kW (175 hp)	160 kW (200 hp)	160 kW (250 hp)	200 kW (300 hp)	250 kW (350 hp)	400 kW (500 hp)
Speed	350 rpm	260 rpm	330 rpm	280 rpm	260 rpm	230 rpm	220 rpm	220 rpm	220 rpm	200 rpm
Basic crusher weight *)	7 670 kg 16 900 lbs	20 060 kg 44 240 lbs	9 759 kg 21 520 lbs	14 350 kg 31 650 lbs	18 600 kg 40 920 lbs	26 000 kg 57 200 lbs	40 100 kg 88 500 lbs	51 200 kg 113 000 lbs	76 500 kg 168 300 lbs	121 510 kg 267 930 lbs
Operational crusher weight **)	9 520 kg 21 000 lbs	23 300 kg 51 390 lbs	11 870 kg 26 170 lbs	17 050 kg 37 590 lbs	21 500 kg 47 300 lbs	29 300 kg 64 700 lbs	44 000 kg 97 000 lbs	61 430 kg 135 200 lbs	88 500 kg 194 700 lbs	137 160 kg 302 440 lbs
Feed opening										
Width	800 mm (32")	1 000 mm (40")	930 mm (37")	1 060 mm (42")	1 150 mm (45")	1 200 mm (47")	1 300 mm (51")	1 400 mm (55")	1 600 mm (63")	2 000 mm (79")
Depth	510 mm (20")	760 mm (30")	580 mm (23")	700 mm (28")	800 mm (32")	870 mm (34")	1 000 mm (39")	1 200 mm (47")	1 200 mm (47")	1 500 mm (59")
Capacity										
Closed side setting	Capacity									
40 mm	55 - 75									
1 1/4"	60 - 80									
50 mm	65 - 95									
2"	75 - 100									
60 mm	80 - 110		105 - 135							
2 1/4"	90 - 120		115 - 150							
70 mm	95 - 135	125 - 175	125 - 155	150 - 185	165 - 205	175 - 240				
2 3/4"	110 - 145	140 - 190	135 - 170	160 - 205	180 - 225	195 - 265				
80 mm	110 - 150	145 - 200	140 - 180	165 - 215	180 - 235	195 - 270				
3 1/4"	120 - 165	160 - 215	155 - 200	185 - 240	200 - 260	215 - 295				
90 mm	125 - 175	160 - 220	160 - 200	190 - 235	205 - 255	210 - 305				
3 3/4"	140 - 190	175 - 240	175 - 220	205 - 260	225 - 280	235 - 330				
100 mm	140 - 190	180 - 250	175 - 225	205 - 265	225 - 285	235 - 325	270 - 369			
4"	150 - 210	200 - 275	195 - 250	230 - 295	245 - 315	260 - 360	297 - 406			
125 mm	175 - 245	220 - 310	220 - 280	255 - 325	270 - 345	285 - 395	325 - 446	340 - 470		
5"	195 - 270	245 - 340	240 - 310	280 - 360	295 - 380	315 - 435	358 - 491	375 - 515		
150 mm	210 - 290	265 - 365	265 - 335	305 - 385	320 - 405	340 - 475	380 - 523	400 - 555	430 - 610	
6"	230 - 320	290 - 400	290 - 370	335 - 428	350 - 450	375 - 515	418 - 576	440 - 610	475 - 670	
175 mm	245 - 335	310 - 430	310 - 390	355 - 450	370 - 465	385 - 540	435 - 600	460 - 635	495 - 695	630 - 890
7"	270 - 370	340 - 470	340 - 430	390 - 495	405 - 515	430 - 595	479 - 661	505 - 700	545 - 765	695 - 980
200 mm		355 - 490		395 - 500		410 - 520	490 - 677	520 - 720	560 - 790	710 - 1000
		390 - 535		445 - 560		460 - 580	539 - 746	570 - 790	615 - 870	780 - 1100
225 mm							545 - 754	580 - 800	625 - 880	785 - 1105
							600 - 830	640 - 880	685 - 965	860 - 1215
250 mm							600 - 831	640 - 880	685 - 965	865 - 1215
							661 - 915	705 - 970	755 - 1060	950 - 1340
275 mm									745 - 1055	940 - 1320
									820 - 1160	1030 - 1455
300 mm									815 - 1145	1015 - 1435
									895 - 1260	1120 - 1575
										Mtph
										Stph

Smaller closed side settings can be often used depending on application and production requirements. For a performance estimation for your specific application, please contact Metso.

The above figures represent through the crusher capacities, which are based on a feed material with an average specific gravity of 2.7 t/m³, a maximum feed size that will enter the crusher without bridging and material finer than the crusher's closed side setting removed. The capacities may vary depending on the feeding method and on feed characteristics such as gradation, bulk density, moisture, clay content and crushability. Measurement of the crusher's closed side setting varies depending on the jaw profile that is being used and has an impact on the crusher's capacity and product gradation. The following factors will enhance crusher capacity and performance:

1. Proper selection of the jaws.
2. Proper feed gradation.
3. Controlled feed rate.
4. Sufficient feeder capacity and width.
5. Adequate crusher discharge area.
6. Discharge conveyor sized to convey maximum crusher capacity.

*) Crusher without options
**) Crusher with options

Metso

Rock breakers



Metso

Rock breaker solutions



Metso rock breaker solutions are complete functional packages for rock breaking in the primary crushing stage. The breaker booms and hammers are engineered to meet the requirements set by rough primary crushing applications. These packages are optimized to work together and support Metso primary crushers, ensuring the best productivity of the whole primary crushing station.

Significant improvement to plant capacity

Long-term plant production is significantly improved when the primary station is equipped with a rock breaker solution. Downtime due to build-ups and blockages can be easily cut to a minimum. This ensures a steady material flow through the primary station to the next process stages. The huge economic impact as a result of improved productivity means that the investment pay-back time is typically very short.

The safest way to manage build-ups

A rock breaker solution is clearly the safest way to manage blockages and build-ups and to clear the crusher cavity. The remote-controlled boom and hammer with the radio remote control, which is part of standard scope of delivery, means that the boom and hammer can be operated from a location that gives the operator unlimited visibility into the area where the rocks are moved or broken. Metso rock breaker solutions are also engineered safe and easy to maintain, with single-point lubrication of the boom joints as a standard feature.

A complete, optimized solution

Metso rock breaker solutions are complete functional packages optimized for primary crushing applications. Each component, breaker boom, rock breaker, hydraulic power unit and radio remote control, is optimized to work most efficiently with the other components. And each complete solution is optimized to work most efficiently with certain Metso crushers. Each component is engineered to meet the requirements set for the equipment used in rough primary crushing applications.

Benefits of Metso's rock breaker solutions

- Safety
- Complete, optimized solution
- Engineered to Metso's standards

Technical specifications						
Breaker boom	MB293™	MB352™	MB432™	MB655™	MB676™	MB1059™
Boom reach	2,9 m (9' 6")	3,5 m (11' 6")	4,3 m (14' 2")	6,5 m (21' 5")	6,7 m (22' 1")	10,5 m (34' 7")
Hammer	MH400™ / MH550™	MH400™ / MH550™	MH1100™	MH1100™	MH1750™	MH2200™
Hammer weight	400 kg (880 lbs) / 550 kg (1 210 lbs)	400 kg (880 lbs) / 550 kg (1 210 lbs)	1 100 kg (2 420 lbs)	1 100 kg (2 420 lbs)	1 750 kg (3 850 lbs)	2 200 kg (4 840 lbs)
Power unit	MPU18™	MPU18™	MPU30™	MPU30™	MPU37™	MPU45™
Power rating	18 kW (25 hp)	18 kW (25 hp)	30 kW (40 hp)	30 kW (40 hp)	37 kW (50 hp)	55 kW (74 hp)
Optimized for	Nordberg® C106™ / C116™	Nordberg® C120™ / C130™	Nordberg® C150™	Nordberg® C160™	Nordberg® C200™	SUPERIOR® Primary Gyrotory



Nordberg®
NP Series™

Nordberg® NP Series™

Why choose Metso's impact crusher?

High performance

- High capacity
- High reduction ratio
- Less sensitive to sticky material than other machines
- High-quality end product, cubical shape

High efficiency

- Quick and easy installation
- Easy to operate
- High mechanical reliability
- High machine availability

Maintenance friendly

- Easy blow bar attachment
- Self Rotor Rotation (SRR)
- Safety devices

Adaptable to all applications

- Wide choice of blow bars and liners
- Third breaker plate
- Full hydraulic setting
- Metso IC™ crusher automation



Impact crushers Nordberg® NP Series™

Metso's focus on customer success is clearly demonstrated in the development of the Nordberg® NP Series™ impact crusher. We have been building impact crushers for 60 years, so we know that our customers are looking for high performance to boost profitability. By combining the best technical solutions, our crushers provide a reliability that lets you focus on your operations.

Crusher efficiency

Nordberg NP Series impact crushers have a unique blow-bar attachment system that provides a higher degree of reliability. NP Series impact crushers are designed to minimize maintenance, to improve adjustment operations and to deliver unbeatable performance in primary, secondary, tertiary and recycling applications.

Plant profitability

NP Series impact crushers feature a unique combination of heavy rotor and crushing chamber design in addition to materials selected for their outstanding wear resistance. This combination has proved revolutionary in improving capacity and product quality while further reducing operating and wear costs.

Benefits

- Process performance
- Maintenance friendly
- Easy operation

Nordberg® NP Series™

Impact crushers

Nordberg NP Series impact crushers feature a unique combination of heavy rotor design, materials selected for good wear resistance and crusher chamber design. This combination has proven revolutionary in improving capacity and product quality and in reducing operating and wear costs. NP Series impact crushers deliver unbeatable performances in primary, secondary, tertiary and recycling applications.

Configured for your needs

NP Series impact crushers are the solution when output and productivity demands are increasingly stringent, from quarry to industrial applications and from mining to recycling. It's easy to build your own crusher configuration -- by adding options for your application -- like a full hydraulic breaker plate adjustment setting, a third breaker plate or different grades of steel and cast iron for the blow bars with the possibility for ceramic inserts. The Self Rotor Rotation system (SRR) is available across the NP range and is part of Metso's ongoing effort to innovate and find ways to enhance the quality, ease of use, and safety of its products. Metso IC™ crusher automation controls the crusher operation and gives a perfect and complete overview of performance.

High performance from NP Series

NP Series impact crushers feature a unique blow-bar attachment system. Combined with perfect blow-bar alignment on the crossbeam contact faces, this reduces risks of breakage and makes it possible to push the use of cast iron for blow bars beyond conventional limits. The rotor with high inertia

improves crushing reduction and provides stability in the process, reducing energy consumption and increasing long-term performance.

Reduced plant operating costs

Continuous collaboration with research laboratories results in state-of-the-art technical innovations in terms of durability of wear parts and reliability of mechanical components. Higher reduction with fewer crushing stages lowers your capital costs and saves energy. Mechanical reliability, and simplified process, easy machine operation, and easy and safe maintenance increase the global availability of the plant and profitability.

Benefits of Nordberg NP Series

- High end-product value
- High plant availability
- Adaptable for all applications
- High quality for low CAPEX

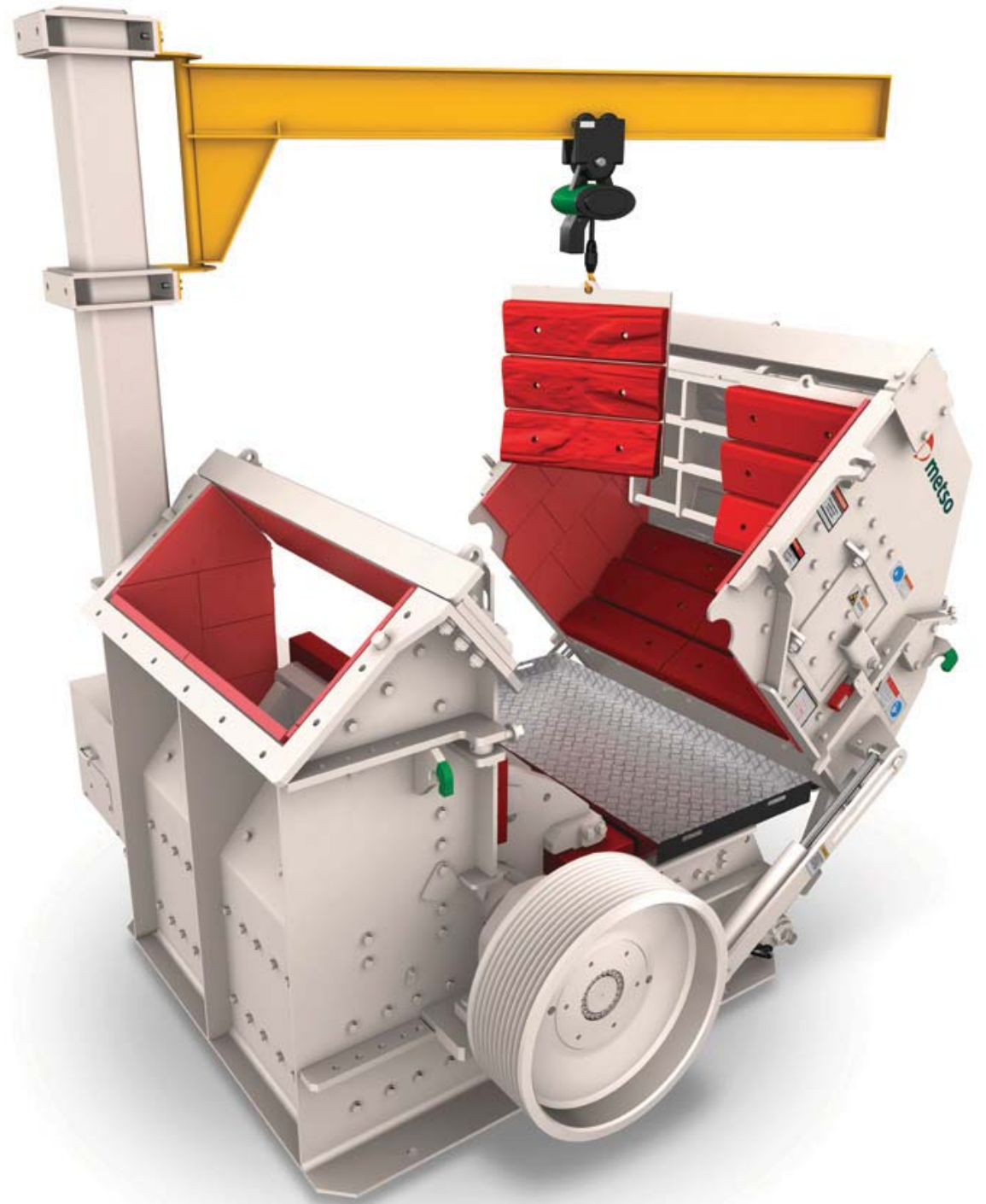



Nordberg® NP Series™

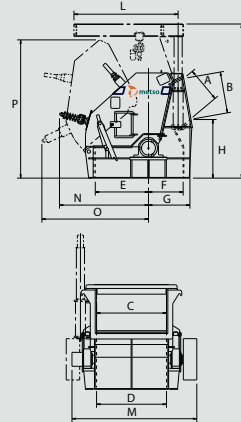

Main dimensions and weights

NP Model		Crusher complete	Rotor complete	Rotor diameter	Rotor width
Primary range	NP1313™	17 800 kg 39 249 lbs	6 340 kg 13 980 lbs	1 300 mm 51 1/4"	1 300 mm 51 1/4"
	NP1415™	22 330 kg 49 230 lbs	8 165 kg 18 004 lbs	1 400 mm 55 1/8"	1 500 mm 59 1/4"
	NP1620™	41 240 kg 90 920 lbs	15 980 kg 35 236 lbs	1 600 mm 63"	2 000 mm 78 1/4"
	NP2023™	80 600 kg 177 700 lbs	28 280 kg 62 357 lbs	2 000 mm 78 3/4"	2 300 mm 90 1/4"
Secondary range	NP1110™	9 250 kg 20 396 lbs	3 065 kg 6 758 lbs	1 100 mm 43 1/4"	1 000 mm 39 3/4"
	NP1520™	27 500 kg 60 660 lbs	10 400 kg 22 932 lbs	1 500 mm 59 1/4"	2 000 mm 78 1/4"
Secondary & tertiary	NP13™	11 700 kg 25 700 lbs	4 850 kg 10 700 lbs	1 200 mm 47 1/4"	1 300 mm 51 1/4"
	NP15™	16 130 kg 35 567 lbs	6 370 kg 14 046 lbs	1 300 mm 51 1/4"	1 500 mm 59 1/4"

Clearance dimensions (mm/inch)

NP Model		A	B	C-D	E	F	G	H	K	L	M	N	O	P	
Primary range	NP1313™	1 050 41 1/4"	1 225 48 1/4"	1 320 52"	1 305 51 1/8"	760 30"	964 38"	1 386 24 1/2"	3 765 148 1/4"	2 100 82 3/4"	2 560 100 3/4"	2 340 92 1/4"	2 764 108 3/4"	3 405 134"	
	NP1415™	1 140 44 7/8"	1 320 52"	1 540 60 5/8"	1 305 51 1/8"	800 31 1/2"	998 39 1/4"	1 430 56 1/4"	4 000 157 1/2"	2 295 90 1/4"	2 811 111"	2 425 95 1/2"	2 830 111"	3 600 141 1/4"	
	NP1620™	1 400 55 1/4"	1 634 64 1/4"	2 040 80 1/4"	1 600 63"	920 36 1/4"	1 270 50"	1 772 69 3/4"	4 950 194 7/8"	3 000 118 1/4"	3 820 150"	2 630 103 1/2"	2 630 122"	3 105 122"	4 400 173 1/4"
	NP2023™	1 720 67 3/4"	1 986 78 1/4"	2 310 91"	2 210 87"	1 140 44 7/8"	1 631 64 1/4"	2 273 89 1/2"	6 000 236 1/4"	3 930 154 1/4"	4 424 174 1/4"	3 520 138 1/4"	4 100 161 3/8"	5 514 217"	
Secondary range	NP1110™	710 28"	820 32 1/4"	1 020 40 1/4"	1 105 43 1/2"	652 25 3/8"	796 31 1/4"	1 125 44 1/4"	3 055 120 1/4"	1 800 70 7/8"	2 106 82 7/8"	1 830 72"	2 030 80"	2 716 107"	
	NP1520™	850 33 1/2"	995 39 1/4"	2 040 80 1/4"	1 368 53 1/8"	885 34 1/4"	1 055 41 1/2"	1 518 59 1/4"	3 950 155 1/2"	3 000 118 1/4"	3 650 144"	2 336 92"	2 763 108 3/4"	3 540 139 1/4"	
Secondary & tertiary	NP13™	560 22"	560 22"	1 320 52"	1 106 43 1/2"	705 27 3/4"	797 31 3/8"	1 558 61 3/8"	3 481 137"	3 050 120"	2 531 100"	1 980 78"	3 050 120"	2 500 98"	
	NP15™	600 23 3/4"	600 23 3/4"	1 540 60 5/8"	1 177 46 3/8"	700 30 1/4"	845 33 1/4"	1 670 65 3/4"	3 840 151"	3 055 120"	3 785 110"	2 050 80 3/4"	3 250 127 7/8"	2 700 106 1/4"	

Technical data

	NP Model	Feed opening	Maximum feed size	Nominal installed power	Maximum installed power
Primary range	NP1313™	1 320 x 1 225 mm (52" x 48 1/4")	900 mm (35")	200 kW / 250 hp	250 kW / 350 hp
	NP1415™	1 540 x 1 320 mm (60 5/8" x 52")	1 000 mm (40")	250 kW / 350 hp	315 kW / 400 hp
	NP1620™	2 040 x 1 634 mm (80 1/4" x 64 1/4")	1 300 mm (51")	400 kW (2x200 kW) / 500 HP (2x250 hp)	500 kW (2x250 kW) / 700 HP (2x350 hp)
	NP2023™	2 310 x 1 986 mm (91" x 78 1/4")	1 500 mm (59")	1 000 kW (2x500 kW) / 1 300 HP (2x650 hp)	1 200 kW (2x600 kW) / 1 600 HP (2x800 hp)
Secondary range	NP1110™	1 020 x 820 mm (40 1/4" x 32 1/4")	600 mm (24")	160 kW / 200 hp	200 kW / 250 hp
	NP1520™	2 040 x 995 mm (80 1/4" x 39 1/4")	700 mm (28")	400 kW (2x200 kW) / 500 HP (2x250 hp)	500 kW (2x250 kW) / 700 HP (2x350 hp)
Secondary & tertiary	NP13™	1 320 mm x 560 mm (52" x 22")	350 mm (14")	250 kW / 350 hp	315 kW / 400 hp
	NP15™	1 540 x 600 mm (60 5/8" x 24")	400 mm (16")	315 kW / 400 hp	355 kW / 450 hp



Nordberg®
HP Series™

Nordberg® HP Series™

Why choose Metso's cone crusher?

Performance

- Capacity
- Reduction ratio
- Final production yield
- Shape
- Power efficient

Reliability

- Field-proven design
- Hydraulic safety system
- Bronze bushings

Energy efficient

- High-yield production
- Large stroke
- High-efficiency motors

Maintenance friendly

- Versatility
- One-piece main frame
- Dismantling from top
- No backing liners
- Metso IC™ crusher automation



Cone crushers Nordberg® HP Series™

Metso is committed to driving customer success. Nordberg® HP Series™ cone crushers help Metso demonstrate this value by offering unprecedented performance: high capacity, superior end-product quality and energy efficiency.

Highest performance

Nordberg HP Series cone crushers feature a unique combination of crusher speed, throw, crushing forces and cavity design. This combination is renowned for providing higher capacity and superior product quality in all secondary, tertiary and quaternary applications. Field proven for years, HP series cone crushers are built to perform.

Cost effective

In a size-class comparison, the HP Series crushers have a higher output capacity, higher density in the crushing chamber and better reduction ratio, producing higher on-spec yield end products with the same energy consumption. HP Series cone crushers are equipped with the latest high-efficiency motors, making them efficient and ecological crushing machines.

Maintenance friendly

Designed for your needs, HP Series cone crushers are safe and easy to maintain. Fast and easy access to all the main components from the top, dual-acting hydraulic cylinders, and no backing material significantly reduce downtime and are more environmentally friendly.

Benefits

- Performance
- Reliability
- Energy efficient
- Less downtime
- Easy to maintain

Nordberg® HP Series™

Cone crushers

Metso is once again on the cutting edge of innovative technology and leading the way with a new generation of cone crushers. Its new-generation HP Series cone crushers are high performers.

Making success happen

In today's dynamic crushing and screening environment, Metso is focused on customer success. We listen to our customers to find out what they need to succeed and then develop solutions to make it happen.

HP for high performance

HP Series cone crushers produce finer products by limiting crushing stages, which lowers your investment cost and saves energy. This is achieved through a combination of optimized speed, large throw, crushing chamber design and increased crushing force. The efficient crushing action of the HP Series gives it the best power utilization per cone diameter.

More power with less energy

Increasing the stroke, the power and the retaining force while improving crusher body design and weight to withstand the force are principles of kinematics. A higher density in the crushing chamber improves the inter-particle crushing action, resulting in superior product shape, high reduction ratio and high capacity.

More uptime, more confidence

Another way the HP Series cone crushers deliver is through less downtime and increased operator confidence.

Dual-acting hydraulic tramp-release cylinders are used to let the crusher pass tramp iron and to provide a large clearing stroke if needed. The double accumulator combination provides better reactivity of the hydraulic system.

User friendly maintenance

Because we are working in potentially hazardous environments, HP Series cone crushers are designed to ensure maximum operator safety and easy maintenance. Accessibility from the top of the crusher to the principal components, easy access for liner maintenance, mechanical rotation of the bowl for removal with a simple press of a button, no backing compound on liners, and full protection with Metso IC™ crusher automation make the Nordberg HP Series the most reliable cone crushers.

Benefits of Nordberg HP Series

- Large stroke
- Strong crushing force
- Attrition
- Reduction ratio
- Antispin
- Dual-acting cylinders





Nordberg® HP Series™

	HP3™	HP4™	HP5™	HP6™	HP100™	HP200™	HP300™	HP400™	HP500™
Technical specifications									
Head diameter	1 000 mm (39")	1 120 mm (44")	1 250 mm (49")	1 400 mm (55")	735 mm (29")	940 mm (37")	1 120 mm (44")	1 320 mm (52")	1 520 mm (60")
Power	250 kW (350 hp)	315 kW (400 hp)	370 kW (500 hp)	500 kW (650 hp)	90 kW (125 hp)	132 kW (200 hp)	220 kW (300 hp)	315 kW (400 hp)	355 kW (500 hp)
Crusher weight *)	16 100 kg (35 600 lbs)	24 200 kg (53 400 lbs)	29 000 kg (64 000 lbs)	44 550 kg (98 200 lbs)	6 470 kg (14 300 lbs)	12 160 kg (26 800 lbs)	18 100 kg (39 900 lbs)	25 600 kg (56 400 lbs)	37 000 kg (81 600 lbs)
Feed opening									
Maximum	220 mm (8 1/4")	252 mm (9 7/8")	317 mm (12 1/2")	331 mm (13")	150 mm (8 1/2")	185 mm (7")	241 mm (9 1/2")	304 mm (12")	351 mm (13 3/4")
Capacity									
Closed side setting	Capacity								
6 mm					45 - 55				
	1/4"				50 - 60				
8 mm	94 - 122	135 - 175	158 - 205		50 - 60				
	5/16"	104 - 135	150 - 190	174 - 226					
10 mm	108 - 147	155 - 210	181 - 246	220 - 300	55 - 70	90 - 120	115 - 140	140 - 175	175 - 220
	3/8"	119 - 162	170 - 230	200 - 271	245 - 330	60 - 75	100 - 130	125 - 155	155 - 195
13 mm	136 - 185	195 - 265	229 - 311	280 - 380	60 - 80	120 - 150	150 - 185	185 - 230	230 - 290
	1/2"	150 - 204	215 - 290	252 - 343	310 - 415	65 - 90	130 - 165	165 - 205	205 - 255
16 mm	164 - 220	235 - 315	275 - 369	335 - 450	70 - 90	140 - 180	180 - 220	225 - 280	280 - 350
	5/8"	181 - 243	260 - 345	303 - 407	370 - 495	80 - 100	155 - 200	200 - 240	250 - 310
19 mm	182 - 241	260 - 345	304 - 403	370 - 490	75 - 95	150 - 190	200 - 240	255 - 320	320 - 400
	3/4"	200 - 266	285 - 380	335 - 444	410 - 540	85 - 105	165 - 210	220 - 265	280 - 355
22 mm	199 - 262	285 - 375	335 - 439	410 - 535	80 - 100	160 - 200	220 - 260	275 - 345	345 - 430
	7/8"	219 - 289	315 - 410	369 - 484	450 - 590	85 - 110	175 - 220	240 - 285	305 - 380
25 mm	210 - 279	300 - 400	352 - 460	430 - 570	85 - 110	170 - 220	230 - 280	295 - 370	365 - 455
	1"	231 - 308	330 - 440	388 - 507	470 - 630	100 - 140	185 - 240	255 - 310	325 - 410
32 mm	217 - 307	310 - 440	380 - 500	440 - 630	110 - 155	190 - 235	250 - 320	325 - 430	405 - 535
	1 1/4"	239 - 339	340 - 485	419 - 551	490 - 690	120 - 170	210 - 260	275 - 355	360 - 475
38 mm	251 - 349	360 - 500	422 - 550	515 - 715		210 - 250	300 - 380	360 - 490	445 - 605
	1 1/2"	277 - 385	395 - 550	465 - 606	565 - 785	230 - 275	330 - 420	395 - 545	490 - 670
45 mm	279 - 388	400 - 555	468 - 600	570 - 790			350 - 440	410 - 560	510 - 700
	1 3/4"	308 - 427	440 - 610	516 - 661	630 - 870		385 - 485	450 - 625	560 - 775
51 mm								465 - 630	580 - 790
	2"							510 - 700	640 - 880

*) Complete crusher weight: crusher + sub frame, motor sub frame, guards, feed and discharge arrangements

Mtph

Stph

Nordberg[®] GP Series[™]



Nordberg® GP Series™

Why choose Metso's cone crusher?

Versatility

- Use the same crusher as a secondary, tertiary or quaternary machine, simply by changing the cavity
- A wide selection of strokes, depending on application
- Can be operated on/off feed

High and stable performance

- Robustly constructed design guarantees durability in high-power applications
- Stable performance throughout the liner life

Easy and safe to use and maintain

- Metso IC™ crusher automation
- Dynamic setting adjustment
- Dismantling from top
- Quick, easy, and cost-effective liner change, no backing material

Cost effective installation

- Low installation height due to patented piston design
- Reduced need of steel structures and conveyor lengths
- Easy to install in place of an existing crusher

Environmentally friendly

- Energy optimized due to stroke adjustment
- Effective utilization of natural raw materials both in design and performance
- No backing material



Cone crushers Nordberg® GP Series™

Nordberg® GP Series™ cone crushers have been developed to crush feed materials into desired end products efficiently, reliably, and economically.

Optimized for your needs

Metso, the global leader in rock crushing technology, has developed the Nordberg GP Series cone crushers for all rock types. Incorporating the latest crusher know-how, the GP Series crushers combine the highest crushing efficiency and end-product quality with the lowest production costs per ton.

Nordberg GP Series cone crushers embody Metso's 100+ years of commitment to first-class crusher design and product development. As a result, the GP Series offers several outstanding features that enable you to work efficiently in any secondary, tertiary or quaternary crushing application. Nordberg GP Series crushers are optimized for your crushing needs, whether your aggregate or mining process requires high reduction, first-class cubicity or great capacity.

Nordberg GP Series crushers provide you with unlimited possibilities in smooth process adaptation and full crushing process automation. All of this is backed by our worldwide, comprehensive pre- and aftersales support services. Take a closer look at the Nordberg GP Series crushers. We know you'll find a GP cone crusher that is ideal for your needs.

Benefits

- High and stable performance
- Versatility
- Cost-effective installation
- Easy and safe to use and maintain
- Environmentally friendly

Nordberg® GP Series™

Secondary cone crushers

The robust design of Nordberg GP Series cone crushers makes it possible to maintain high power levels that result in high productivity. The proven heavy-duty design and the use of high-quality Metso components with optimized wear parts keep production up and operating costs down.

Best long-term performance

Optimized cavity designs by the industry leader provide maximum yields for required high-quality end products. The stroke and cavity change feature allows crusher throughput to be easily adjusted to work in harmony with the rest of the crushing plant.

The steep head angle in secondary GP cone crushers guarantees trouble-free operation in varying feed conditions with a high reduction ratio. Continuing process and crusher control ensures high availability with optimum production levels of desired end products.

The Nordberg GP Series cone crusher is the right machine to maximize your profitability.

Increased production of desired end-product fractions

The robust design of GP Series cone crushers makes it possible to maintain high crushing power and pressure that leads to higher end-product capacity. Nordberg GP series secondary crushers are designed especially for efficient secondary crushing or primary gravel crushing applications.

The crushers provide maximum feed opening for undisturbed operation with big feed, calibrating material to a consistent, easy-to-process size for the following crushing and screening stages.

Superior reliability

The reliability and safe operation of Nordberg GP Series cone crushers are the result of their unique design and high-quality steel. Their reliability in demanding crushing applications is guaranteed by Metso's acclaimed metallurgical know-how, and ongoing development of manganese materials, metallurgical compounds and geometrical design.

Benefits of Nordberg GP Series secondary crushers

- Best long-term performance
- Reliability in demanding applications
- First-class end-product shape
- High reduction ratio



Nordberg® GP Series™

Tertiary cone crushers

The robust design of the GP Series cone crushers enables high power levels and high productivity. The proven heavy-duty design and use of high-quality components with optimized wear parts keep operating costs down.

The highest performance and excellent end-product quality

The optimized design of the Nordberg GP Series castings enables the use of a higher power rating than any other cone crusher with an equal head diameter. The castings design together with high-quality Metso components make it possible to maintain high crushing performance in the toughest conditions. High crushing forces, excellent cavity geometry and proven kinematics in tertiary applications result in first-class end-product shape and increased production of desired end-product fractions.

The dynamic setting control maintains excellent, stable end-product quality. The crusher setting can be continuously adjusted under load in all Nordberg GP Series cone crushers. Metso IC™ crusher automation maintains a high power draw and compensates for liner wear during crushing without interruptions.

One crusher for the secondary, tertiary and quaternary crushing stage

Nordberg GP Series cone crushers are always adapted to your specific production requirements. A high power rating with a wide selection of cavities and strokes enables the use of the same crusher for

the 2nd, 3rd or 4th crushing stages. The stroke change feature allows crusher through-put to be easily adjusted to work in harmony with the rest of the crushing plant. The adjustable stroke also allows you to attain proper choke feed conditions and optimum crusher settings, ensuring the maximum yield of a required end-product size.

Guaranteed performance

Nordberg GP Series crushers are designed to be easy to maintain and service. When OEM parts are used, a long lifetime is guaranteed. Metso IC crusher automation ensures that your GP cone crusher runs at its optimal performance level.

Benefits of Nordberg GP Series tertiary crushers

- The highest performance and excellent end-product quality
- One crusher for stages 2, 3 and 4
- Reliability in demanding applications
- First-class end-product shape
- Wide range of cavities

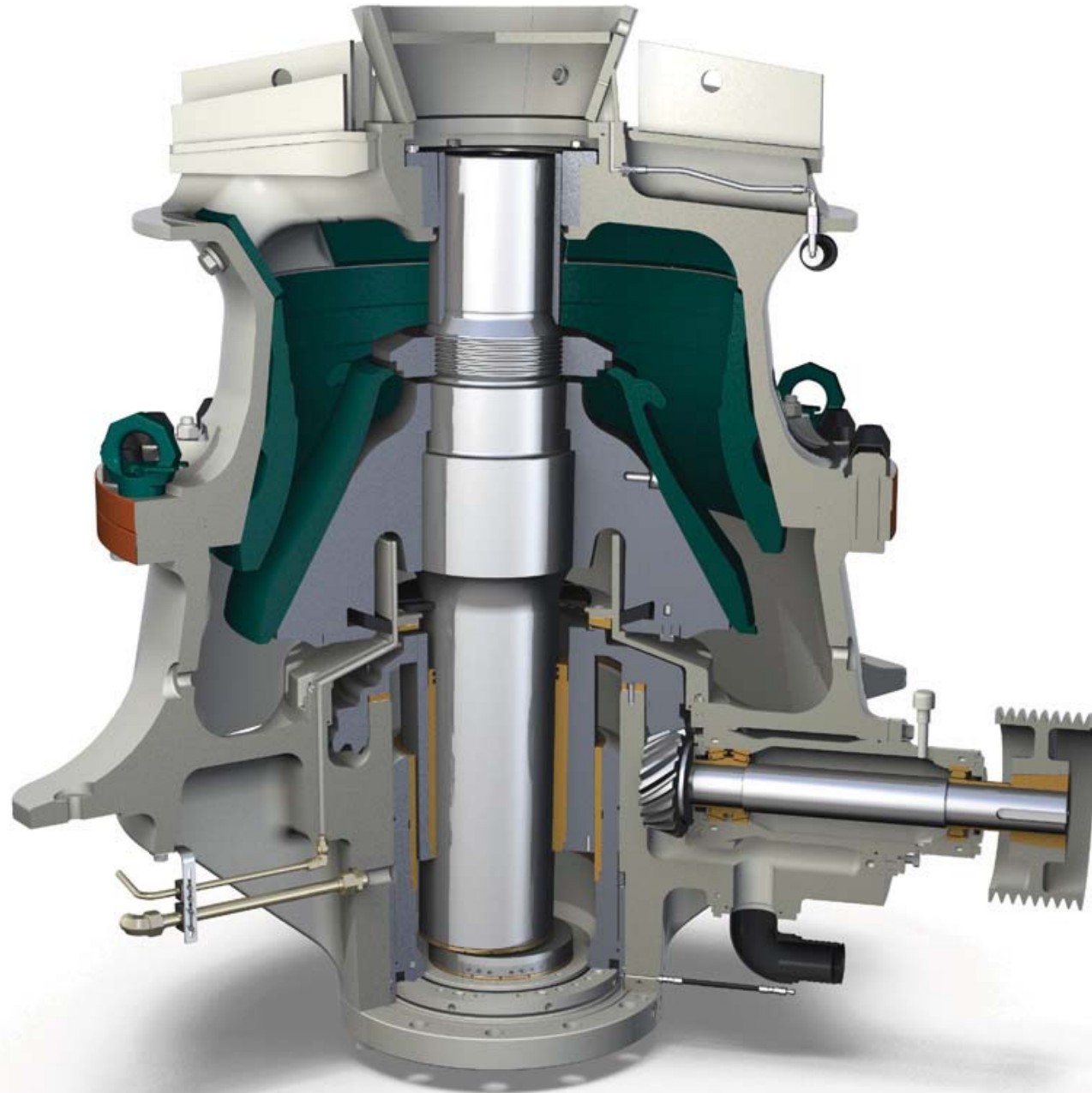

Nordberg® GP Series™



	GP1005™	GP2005™	GP3005™	GP5005™	GP7™	GP100™	GP220™	GP330™	GP550™
Technical specifications									
Power	75 - 90 kW (100 - 125 hp)	110 - 160 kW (150 - 225 hp)	132 - 250 kW (175 - 350 hp)	200 - 355 kW (275 - 475 hp)	375 - 560 kW (500 - 750 hp)	75 - 90 kW (100 - 125 hp)	132 - 220 kW (175 - 300 hp)	250 - 315 kW (325 - 425 hp)	250 - 400 kW (325 - 500 hp)
Basic crusher weight *)	7 350 kg 16 200 lbs	10 900 kg 24 000 lbs	16 200 kg 35 700 lbs	33 300 kg 73 400 lbs	61 000 kg 135 000 lbs	5 800 kg 12 800 lbs	10 200 kg 22 500 lbs	15 700 kg 34 600 lbs	26 500 kg 58 400 lbs
Feed opening									
Cavity	Feed opening								
EF						46 mm (1 9/16")	58 mm (2 5/16")	**)	68 mm (2 3/4")
F						53 mm (2")	89 mm (3 1/2")	85 mm (3 3/8")	95 mm (3 3/4")
MF						95 mm (3 3/4")	101 mm (4")	107 mm (4 1/4")	113 mm (4 7/16")
M	206 mm (8 1/8")					141 mm (5 9/16")	118 mm (4 5/8")	135 mm (5 1/8")	152 mm (6")
C	239 mm (9 9/16")	222 mm (8 3/4")	247 mm (9 3/4")	321 mm (12 5/8")	335 mm (13 1/8")	142 mm (5 5/8")	182 mm (7 1/8")	184 mm (7 1/4")	192 mm (7 9/16")
EC		295 mm (11 5/8")	332 mm (13 1/8")	401 mm (15 3/4")	414 mm (16 1/4")		213 mm (8 3/8")	225 mm (8 7/8")	250 mm (9 13/16")
EC-LS / EC-TR			332 mm (13 1/8")	442 mm (17 7/8")	450 mm (17 9/16")		213 mm (8 3/8")	225 mm (8 7/8")	265 mm (10 7/16")
Stroke									
Stroke options	16, 20, 25 mm (5/8, 3/4, 1")	18, 25, 28, 32, 36 mm (7/8, 1, 1 1/8, 1 1/4, 1 1/2)	18, 22, 25, 28, 32, 36 mm (7/8, 1, 1 1/8, 1 1/4, 1 1/2)	18, 25, 28, 32, 36, 40 mm (7/8, 1, 1 1/8, 1 1/4, 1 1/2, 1 3/8)	25, 28, 32, 36, 40, 45, 50 mm (1, 1 1/8, 1 1/4, 1 1/2, 1 3/8, 2")	16, 20, 25 mm (5/8, 3/4, 1")	18, 25, 28, 32, 36, 40 mm (7/8, 1, 1 1/8, 1 1/4, 1 1/2)	18, 22, 25, 28, 32, 36, 40 mm (7/8, 1, 1 1/8, 1 1/4, 1 1/2)	25, 28, 32, 36, 40, 45 mm (1, 1 1/8, 1 1/4, 1 1/2, 1 3/8)
Capacity									
Closed side setting	Capacity								
6 mm						35 - 50			
1/16"						39 - 55			
8 mm						40 - 65	70 - 90	105 - 145	
5/16"						44 - 72	77 - 99	116 - 160	
10 mm						45 - 73	80 - 130	110 - 190	140 - **)
3/8"						49 - 80	88 - 143	121 - 210	155 - **)
15 mm						50 - 95	105 - 175	130 - 260	160 - 310
19/32"						55 - 105	115 - 192	143 - 286	176 - 341
20 mm	80 - 90					65 - 105	120 - 230	155 - 300	190 - 340
25/32"	88 - 99					72 - 116	132 - 253	170 - 330	209 - 374
25 mm	105 - 155	110 - 160	180 - 200				150 - 265	180 - 350	230 - 410
1"	116 - 170	121 - 176	198 - 220				165 - 292	198 - 385	253 - 451
30 mm	120 - 195	150 - 265	170 - 290		350 - 450		165 - 280	210 - 390	250 - 450
1 1/16"	132 - 214	165 - 292	187 - 319		386 - 496		182 - 308	230 - 430	275 - 495
35 mm	135 - 220	190 - 330	200 - 400		430 - 640		180 - **)	265 - **)	280 - 510
1 1/8"	149 - 242	209 - 363	220 - 440		474 - 705		198 - **)	292 - **)	308 - 561
40 mm	145 - 230	210 - 365	215 - 440		500 - 840				350 - **)
1 9/16"	160 - 253	231 - 402	236 - 484		551 - 926				385 - **)
45 mm	155 - 250	230 - **)	235 - **)	300 - 470	580 - 970				400 - **)
1 3/4"	170 - 275	243 - **)	259 - **)	330 - 517	640 - 1070				440 - **)
50 mm		240 - **)	260 - **)	375 - 670	650 - 1140				
2"		264 - **)	286 - **)	413 - 737	716 - 1257				
55 mm				400 - 750	750 - 1260				
2 1/16"				440 - 825	826 - 1388				
60 mm				450 - 800	830 - 1380				
2 3/16"				495 - 880	915 - 1521				
65 mm				470 - 870	900 - 1500				
2 9/16"				517 - 957	992 - 1653				
70 - 80 mm				500 - **)	980 - **)				
2 3/4 - 3 1/8"				550 - **)	1080 - **)				
80 - 90 mm					1130 - **)				Mtph
3 1/8 - 3 9/16"					1246 - **)				Stph

*) Crusher without options
**) Please contact Metso for more information

The image shows two Barmac mobile crushers in operation at a quarry. A conveyor belt on the left feeds material into the first crusher, which is labeled 'Barmac B9 1005A V2'. A second conveyor belt on the right feeds material into the second crusher, labeled 'Barmac B9 1005A V2'. Both crushers are white with red accents and are mounted on a metal frame. The background shows a large pile of crushed material and the structural steel of the quarry. A yellow safety railing is visible in the foreground.

Barmac[®]
B Series[™]

Barmac® B Series™

Why choose Metso's VSI crusher?

Maximized availability

- Orange Series rotor - Uptime can be significantly increased through shorter maintenance breaks and longer life of wear parts
- Metso IC™ crusher automation

High-quality products

- Unique rock-on-rock principle results in superior cubical shape
- Performance is easy to fine-tune by rotor speed or cascade ratio
- Parts wear has no effect on product gradation or quality

Easy to install and maintain

- Minimal foundation requirements
- Maintenance lifting tools available
- Inspection door for rotor access
- Orange Series rotor for quick & easy maintenance and maximized uptime

Safety

- Interlocking device prevents the access when operating
- Specialized tools for rotor service and crusher top half lifting



VSI crushers Barmac® B Series™

Barmac® B Series™ Vertical Shaft Impactor (VSI) is the original rock-on-rock impactor. It has become synonymous with high-quality products in quarrying and minerals processing industries.

Proven producer of premium quality

The crushing process makes Barmac VSI unique. Whereas most other types of crushers use metallic parts to crush rock, Barmac VSI uses the rock fed into the machine to crush itself. This autogenous crushing action offers the lowest possible cost per ton of any impact crushing method. The high velocity impact crushing achieved in a Barmac VSI improves the soundness and shape of the material and produces the highest quality end products on the market today. It is widely known that the more cubical your product, the better its performance in concrete, asphalt and base mixtures.

Barmac VSI is usually applied in the last phase of the crushing circuit. The quarrying and construction industry has always been Barmac VSI's main application area with thousands of units operating around the world, followed by many demanding manufactured sand, heap leaching, pre-grinding, industrial minerals and recycling applications. This is possible because of the unique free-impact crushing and grinding action combined with the ability to accept fines in the feed and to fine-tune the crusher's performance by simply changing the rotor speed or cascade ratio.

Benefits

- Produces a product of superior cubical shape
- Ability to control product grading
- Low wear costs due to unique rock-on-rock crushing
- Accepts fine material in feed

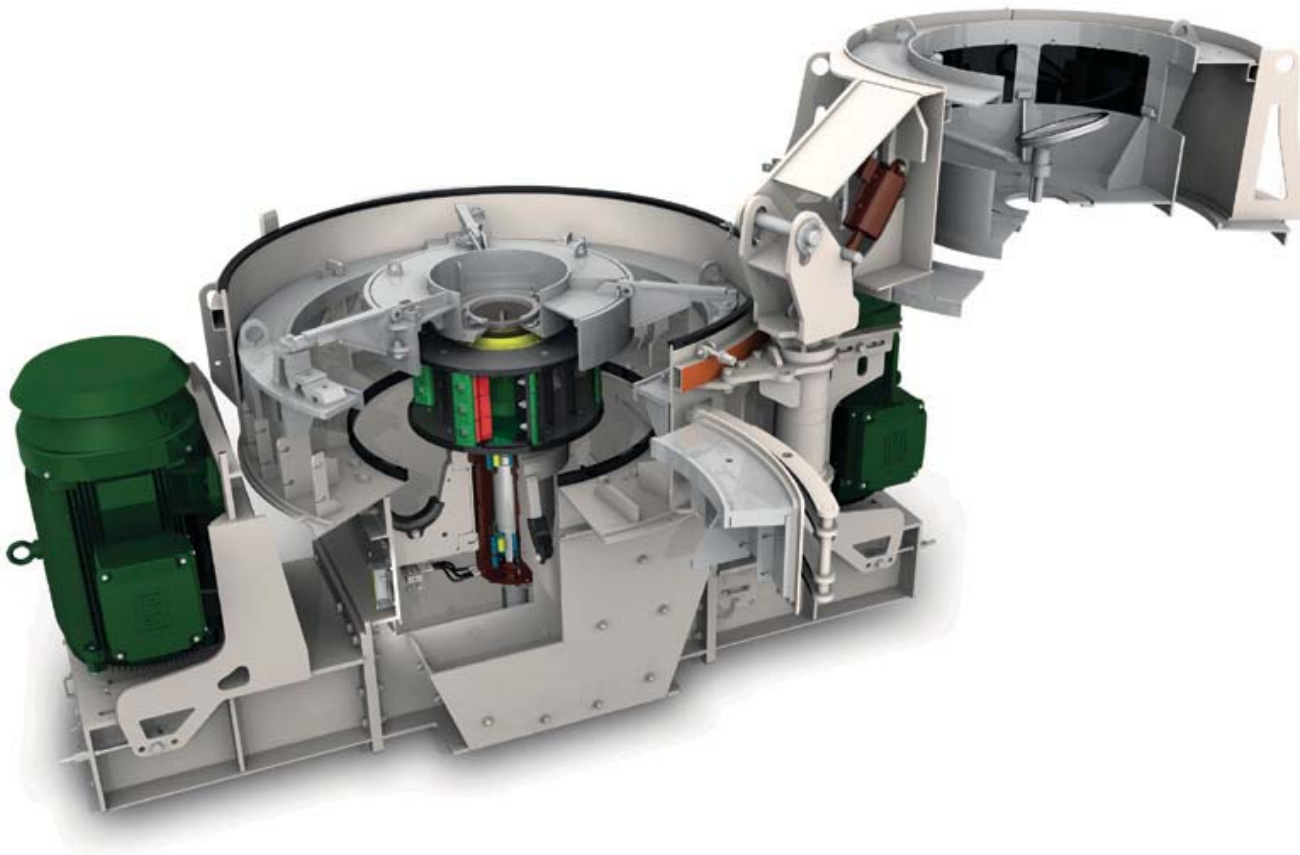

Barmac® B Series™ VSI Your competitive advantage

Barmac B Series VSI is unbeatable when you require maximum availability, low operational costs, consistent high-quality products, and a VSI crusher that meets all the latest safety requirements.

The heart of success

The Barmac VSI rotor has been developed to prolong the lifetime of its wear parts and to increase the operational availability by reducing the time needed for parts changes. Deep rotor technology (DTR) makes it possible to reach the highest possible capacities with the lowest possible power consumption.

Genuine premium-quality Metso parts assure trouble-free operation. The right materials and profiles can be supplied for a long lifetime of crushing.

Cascading optimizes quality

The primary path for the feed material is through the rotor where material can be accelerated up to rotor tip speeds of 80 m/s (262 ft/s) before being discharged into the crushing chamber. Additionally, material may be cascaded into the crushing chamber, bypassing the rotor. The cascade feature enables the operator to optimize the capacity and power consumption and to manipulate the product grading and shape to meet all specification requirements.

User-friendly and minimizes downtime

Barmac B Series VSI is designed with ease of installation in mind. Foundation requirements are minimal due to the low static and dynamic forces in operation.

Service time is drastically reduced with quick access to the rotor parts via a safe-to-use inspection door. The roof lifter and rotor service arm eliminate the requirement for an external crane in regular maintenance and give easy access to the internal workings and rapid rotor changes. Simple and reliable automatic lubrication handles the daily greasing of the main shaft. Metso IC™ crusher automation ensures safe operation and condition monitoring.

Benefits of Barmac B Series

- Deep rotor technology maximizes capacity (DTR)
- Fine-tune product with cascading
- Multiple optional features to help installation and maintenance
- Metso parts for trouble-free operation



Barmac® B Series™

	B6150SE™	B7150SE™	B9100SE™
Technical specifications			
Maximum feed size *)	37 mm (1 ½")	45 mm (1 ¾")	50 mm (2")
Speed	1 500 - 2 500 rpm	1 100 - 2 100 rpm	1 000 - 1 800 rpm
Power	75 - 160 kW (100 - 200 hp)	160 - 320 kW (200 - 400 hp) **)	320 - 600 kW (400 - 800 hp)
Operational crusher weight ***)	6 400 kg 14 100 lbs	12 400 kg 27 300 lbs	14 400 kg 31 700 lbs
Capacity			
Minimum capacity	60 Mtph	125 Mtph	263 Mtph
	66 Stph	137 Stph	289 Stph
Maximum capacity with cascade	217 Mtph	545 Mtph	775 Mtph
	238 Stph	599 Stph	852 Stph

*) Square mesh
 **) Up to 220 kW (300 hp) single-drive configuration
 ***) Including motors

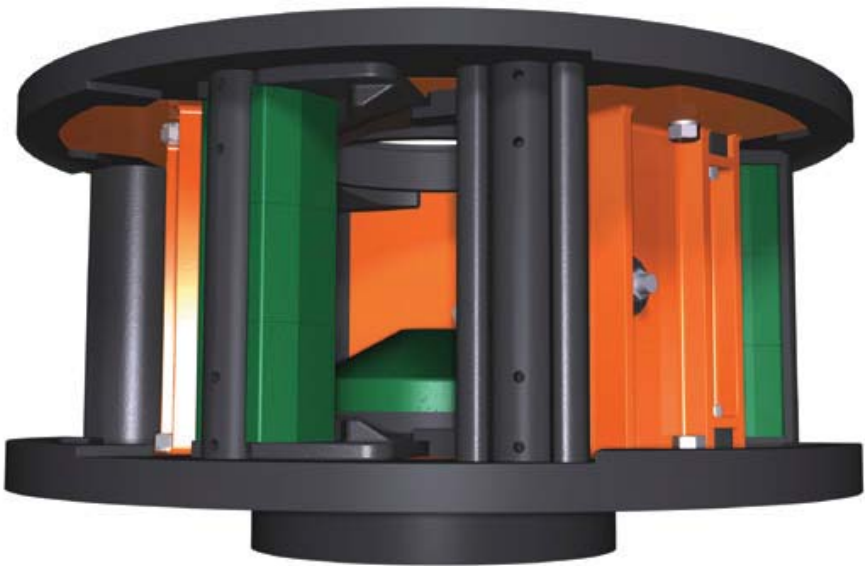

Metso's new Orange Series Rotor is a user-friendly and cost-effective solution for your VSI application. Uptime can be significantly increased through shorter maintenance breaks and longer life of wear parts.

Metso IC™ crusher automation

Crusher automation

A comprehensive range of Metso IC™ intelligent crusher automation solutions is available for Metso crushers. Metso IC automation ensures full performance and is precisely designed to meet your expectations and crushing plant requirements for consistent performance, safety and easy control of crusher parameters.

The automation brings precision and consistency to your crusher operations. This leads to predictable and stable production and end-product quality, and thus ensures profitable operation of the crusher and the whole crushing plant. With optimized start-up and shut-down procedures and sequences integrated into the IC automation, you can be sure that the crusher is working correctly in all circumstances and that the downtime of the crusher is minimal.

Metso IC crusher automation allows you to maximize the performance of your high-quality Metso crushers. This is done with carefully defined safety parameters for oil temperature, power draw and oil pressure, which are indicators of the actual crusher load. Metso IC crusher automation monitors the crusher condition and gives an early indication if there's a problem in the crusher. This can help solve a problem before it becomes serious and costly.

Metso IC crusher automation can be easily connected to any plant automation system used in the crushing and screening industry. This enables centralized control of the crusher and the whole plant, allowing the operator to safely control and alter crusher operating parameters according to production needs from a single location.

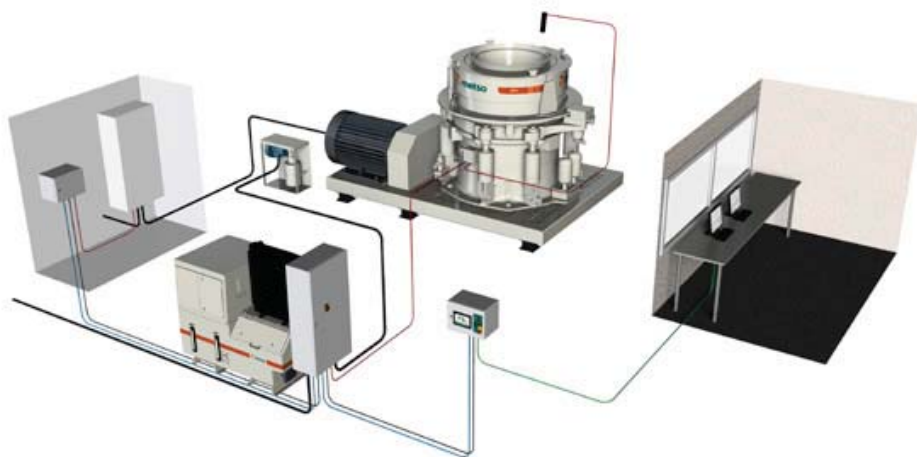

Easy integration to any plant automation system is one of the benefits of Metso IC crusher automation.



Metso IC crusher automation is easy and safe to use. The process can be started and stopped by pressing one single button.



Metso IC crusher automation adjusts the crushing process automatically. You can also benefit from the special fine-adjustment features that enable easy crushing process optimization.

A photograph of a large industrial mining facility. In the foreground, a long conveyor belt with a metal frame and rollers is filled with grey gravel. In the background, a large white building with a dark blue steel frame houses several large, horizontal, cylindrical vibrating screens. A yellow piece of machinery is positioned in front of the building. To the left, a large pile of brown material is visible. The scene is set in a hilly, green environment.

Metso

Vibrating equipment



Metso Vibrating equipment

Metso feeders and screens deliver optimal uptime and the lowest total cost to operate with trouble-free, reliable designs and high availability of wear and spare parts.

Dependable screening performance

In addition to being a provider of crushing and complete rock and mineral processing solutions, Metso has also gained a worldwide reputation as a specialist in vibrating equipment. As an example, more than 3000 units of the highly recognized and robustly designed Metso PREMIER CVB™ screen have been sold and now deliver reliable screening results all around the world.

Maintenance friendly

Our well proven Metso modular MV™ vibrators with the cardan shaft design are uniquely easy to maintain. Unlike conventional designs, our MV vibrators have doubled bearings that ensure extended bearing life. The modular design and highly available wear and spare parts combined with a low-stress designed screen body provide for maximize uptime.

Worker safety

Ease of maintenance and worker safety are a priority, and Metso's vibrating solutions lead the way. Whatever your process requirements, Metso has the right solution - from dependable inclined, high-energy horizontal or high-capacity banana screens. Just name your application, and Metso's professionals will find the most productive and cost-effective vibrating equipment for you.

Benefits

- Reliability
- Availability
- Performance
- Lowest total cost
- Worker safety

Metso PREMIER and COMPACT screens

Why choose Metso's screen?

Performance

- Easy adjustability of stroke & speed
- Extensive selection of screening panels type
- Extensive selection of upgrade options

Worker safety

- Comfortable room between the decks
- High safety belt guards design
- Safety coil spring covers
- Rubber stabilizers as standard
- Configured to be equipped with dust and noise protection

Durability

- MV™ vibrators: long bearing life (double bearing design)
- Weld free side plates and huck-bolted assembly
- Robust deck frame design
- Uncompromised wear protection standard

Maintenance friendly

- Modular MV™ vibrators and cardan shaft design
- Easy access and quick replacements of screening media
- Easily replaceable modular crossbeam protection
- Modular wear and impact resistance rubber linings
- Centralized and conveniently located greasing manifold



Inclined screens Metso PREMIER CVB™

The Metso PREMIER CVB™ is the screen for you when you want a versatile and durable partner in your screening process.

Lowest total cost of your screening operation

Metso PREMIER CVB™ has one of the industry's strongest legacies in the industry of delivering dependable screening performance. Its uniquely robust deck frames are an example of its enhanced durability and reliability. The shaft line is positioned at the center of gravity, a perfect circular motion results on all points on the screen. Combined with an adjustable slope angle from 12-22° this circular motion gives very good screening efficiency for all types of applications, such as primary, technical and final screening. The weld-free crossmember sections reduce the risk of fatigue stress and optimize the product lifetime. In addition, the CVB Series has weld-free side plates, which increases the screen's durability and stress tolerance. Huck-bolting gives you perfect and homogeneous assembling conditions and eliminates the risk of detachment. Size for size, the CVB Series inclined screens are often the most economical in terms of capital expenditure and power consumption compared to other types of screens.

Metso PREMIER CVB has been designed to deliver the lowest total cost to operate with its trouble-free design and high availability of wear and spare parts, which eliminates expensive downtime due to high-cost customized items with low availability.

Benefits

- Circular motion with up to 4G
- Adjustable incline 15°-20°
- High safety design
- High-quality wear protection
- Metso MV™ vibrators



Horizontal screens Metso PREMIER ES™

Ramp up your screening efficiency with the revolutionary, high-energy elliptical motion Metso PREMIER ES™ screen.

High-efficiency screening

Metso PREMIER ES™ screens feature two unbalanced shaft lines rotating in opposite directions to generate a high-energy elliptical motion. This deceptively simple solution is more efficient than conventional horizontal screens that have a linear motion, and the ES Series is more reliable than other elliptical motion screens. What's more, the ES Series separates your materials with consistency and accuracy, even in damp and sticky conditions. The high-energy elliptical motion of the ES Series gives you up to 25% greater capacity than a conventional screen of the same size. In difficult screening conditions – such as wet screening or screening of sticky and dirty materials – the ES Series provides exactly the kind of aggressive screening action you need. Capable of handling all kinds of material, from quarry solid to gravel, you can trust the ES Series to perform reliably in applications that require a high level of screening accuracy. The ES Series is designed to keep downtime and maintenance to a minimum, as there is no mechanical timing device, no gears, no belt and no oil leakage. Quite simply, there's very little that can go wrong.

Compared with other elliptical motion screens, the ES Series is designed with up to 50% more space between the decks.

Benefits

- Elliptical motion with up to 6G
- High-energy screening
- Adjustable incline 0-5°
- Easy maintenance and safe access
- Metso MV™ vibrators



Multi-slope screens Metso PREMIER TS™

The Metso PREMIER TS™ is what you need when you are looking for uniquely designed high-capacity screens.

High-capacity screening

The Metso PREMIER TS™ banana screen is a triple-slope screen ensuring a fast travel speed with an elliptical motion in the first slope, medium travel speed and circular motion in the second slope, and a low travel speed, backwards rotating elliptical motion in the last section. The slower travel speed and strong stratification effect ensures more time and more surface to screen the near-size particles. A single shaft located above the center of gravity generates the elliptical motion with variable angles.

The TS Series banana screen delivers up to 40% more capacity than a standard inclined screen – especially when the feed material contains a high percentage of fines. Creating a safe working environment is one of Metso's top priorities. Safety solutions are not an add-on, but part of our standard offering. This is another factor that puts the TS Series ahead of the competition. The feedbox, discharge spout and cardan shaft come with high-quality, impact-resistant rubber linings as standard. Upgrade options, such as replaceable modular crossbeam protection and Trellex® LS™ modular screening media, make the screen well suited for high-capacity applications with ensured uptime.

Benefits

- Elliptical motion up to 6G
- High-energy screening
- Multi-slope inclines 25°-20°-15°
- Easy maintenance and safe access
- Metso MV™ vibrators

Optimize your screen

Multiple options for your needs

A wide offering of options enables you to customize your screen to meet your needs. Full and appropriate use of these options helps to optimize the efficiency and uptime of your plant.



Modular screening media

- Trellex® LS, RU and PU

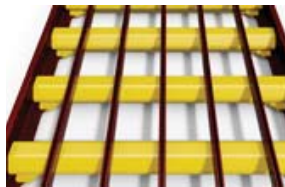

Crossmember protection

- Trellex® CMP polyurethane



Dust sealing system

- Trellex® dust control



Side tension screening media

- Trellex® TCO RU and PU



Spray pipe unit

- Ideal package for wet screening



Galvanization treatment

- Optimal corrosion protection



Automatic greasing kit

- Electrical power greasing unit



Anti-blinding system kit

- Trellex® ABR polyurethane anti-blinding rods



Modular rail-wear protection

- Trellex® polyurethane HD upgrade strip

Technical specifications

Metso PREMIER CVB™ inclined screens					
Range	Deck dimension	Area	Decks	MV vibrator	Weight *)
CVB102P™ CVB103P™	1 565 x 3 660 mm	5.7 m ²	2	2 x MV2	4 800 kg (10 580 lbs)
	5' x 12'	60 ft ²	3		5 800 kg (12 790 lbs)
CVB202P™ CVB203P™	1 870 x 4 880 mm	9.1 m ²	2	2 x MV3 2 x MV3	7 800 kg (17 200 lbs)
	6' x 16'	96 ft ²	3		9 800 kg (21 600 lbs)
CVB302P™ CVB303P™	1 870 x 6 100 mm	11.4 m ²	2	2 x MV3 2 x MV3	7 800 kg (17 200 lbs)
	6' x 20'	120 ft ²	3		11 500 kg (25 350 lbs)
CVB402P™ CVB403P™	2 480 x 6 100 mm	15.1 m ²	2	2 x MV3 2 x MV4	11 700 kg (25 800 lbs)
	8' x 20'	160 ft ²	3		17 000 kg (37 480 lbs)
CVB502P™ CVB503P™	2 480 x 7 320 mm	18.2 m ²	2	2 x MV4 4 x MV3	15 000 kg (33 000 lbs)
	8' x 24'	192 ft ²	3		21 000 kg (46 200 lbs)
CVB102™ CVB103™ CVB104™	1 565 x 3 660 mm	5.7 m ²	2	2 x MV2	5 000 kg (11 020 lbs)
	5' x 12'	60 ft ²	3		6 000 kg (13 230 lbs)
			4		7 000 kg (15 430 lbs)
CVB202™ CVB203™ CVB204™	1 870 x 4 880 mm	9.1 m ²	2	2 x MV3	8 000 kg (17 640 lbs)
	6' x 16'	96 ft ²	3		10 080 kg (22 220 lbs)
			4		12 280 kg (27 070 lbs)
CVB302™ CVB303™ CVB304™	1 870 x 6 100 mm	11.4 m ²	2	2 x MV3 2 x MV3 2 x MV4	10 500 kg (23 150 lbs)
	6' x 20'	120 ft ²	3		11 900 kg (26 235 lbs)
			4		14 000 kg (30 865 lbs)
CVB402™ CVB403™ CVB404™	2 480 x 6 100 mm	15.1 m ²	2	2 x MV3 2 x MV4 2 x MV4	12 000 kg (26 450 lbs)
	8' x 20'	160 ft ²	3		17 000 kg (37 480 lbs)
			4		21 000 kg (46 200 lbs)
CVB502™ CVB503™	2 480 x 7 320 mm	18.2 m ²	2	2 x MV4 4 x MV3	16 000 kg (35 275 lbs)
	8' x 24'	192 ft ²	3		22 500 kg (49 600 lbs)
CVB602™ CVB603™	3 070 x 7 320 mm	22.5 m ²	2	4 x MV3 4 x MV4	21 000 kg (46 300 lbs)
	10' x 24'	240 ft ²	3		23 000 kg (50 700 lbs)
Metso PREMIER ES™ horizontal screens					
Range	Deck dimension	Area	Decks	MV vibrator	Weight *)
ES202™ ES203™	1 870 x 4 880 mm	9.1 m ²	2	2 x MV2 / 2 x MV3	9 500 kg (20 950 lbs)
	6' x 16'	96 ft ²	3		10 500 kg (23 150 lbs)
ES302™ ES303™	1 870 x 6 100 mm	11.4 m ²	2	2 x MV2 / 2 x MV3	9 500 kg (20 950 lbs)
	6' x 20'	120 ft ²	3		11 500 kg (25 350 lbs)
ES402™ ES403™	2 480 x 6 100 mm	15.1 m ²	2	2 x MV3 / 2 x MV4	12 360 kg (27 250 lbs)
	8' x 20'	160 ft ²	3		16 500 kg (36 380 lbs)
Metso PREMIER TS™ multi-slope screens					
Range	Deck dimension	Area	Decks	MV vibrator	Weight *)
TS2.2™ TS2.3™	1 500 x 5 000 mm	7.5 m ²	2	2 x MV2	6 000 kg (13 230 lbs)
	4.9' x 16.4'	80.4 ft ²	3		8 000 kg (17 640 lbs)
TS3.2™ TS3.3™	1 800 x 6 000 mm	10.8 m ²	2	2 x MV3 2 x MV3	8 000 kg (17 640 lbs)
	5.9' x 19.7'	116.2 ft ²	3		10 000 kg (22 050 lbs)
TS4.2™ TS4.3™	2 400 x 6 000 mm	14.4 m ²	2	2 x MV4 2 x MV4	9 000 kg (19 840 lbs)
	7.9' x 19.7'	155.6 ft ²	3		12 000 kg (26 455 lbs)

*) Values are indicative only. Please contact Metso for more information.



Primary scalpers Metso VG™

Metso VG™ primary scalpers have been designed for the toughest applications, high capacity and the ability to process abrasive material, either in stationary or mobile plants.

High scalping efficiency means more tonnage

Metso VG™ primary scalpers are able to maximize the efficiency of the primary plant across a wide variation of application.

VG primary scalpers can be used with different types of feeders, such push feeders, apron feeders or vibrating pan feeders.

The speed and stroke are easily adjustable, ensuring optimal feed control of the primary crusher. A long stroke capability means better scalping efficiency, delivering a linear motion with high G force (5.5 G). Our scalping grizzlies are slightly inclined at 5° to reduce blinding when feed is sticky and contains fines (increased capacity). It can be fitted with various grizzly bar options that ensure wide separation flexibility. The vibrator beam is weld-free and fully huck-bolted to ensure optimal, robust performance. The MV vibrator and cardan shaft design ensure a much more reliable operation than a direct belt-drive design.

Benefits

- Metso MV™ vibrators
- High G force
- Adjustable stroke
- Fully huck-bolted design
- Easy maintenance



Grizzly feeders Metso VF™

Metso VF™ grizzly feeders have been designed for the toughest applications, high capacity and the ability to process abrasive material, either in stationary or mobile plants.

Maximized efficiency of the primary section

A long stroke capability means better scalping efficiency, especially when feed material contains a high ratio of flaky material. In addition to delivering good process control and flexibility for your operation, our VF™ feeders are designed to ensure easy maintenance and secured reliability.

The primary feeds are equipped with our acclaimed MV vibrators with a cardan shaft design, similar to our screens. The MV design not only ensures high availability of spare parts but also an unbeatable combination of easy maintenance and excellent durability.

Our vibrating units can be optimized for your specific needs through a wide range of options. You can choose an electrical or hydraulic drive, a steel or rubber lining, a vibrating chute underneath the grizzly section and an automatic greasing unit.

Benefits

- Metso MV™ vibrators
- Various grizzly bar options
- Adjustable stroke
- Fully huck-bolted design
- Easy maintenance



Compatibility with primary plants

Jaw crusher	Grizzly feeder		Separate feeder + grizzly scalper			Recommended for			Capacity *)	Top feed size *)
	Mobile	Stationary	Pan feeder	Push feeder	Grizzly scalper	Regular	Sticky feed	A lot of fines in the feed		
			Stationary							
C80™	TK8-27-2V	TK8-32-2V							300 mtph (340 stph)	450 mm (18")
C96™	TK9-32-2V	TK9-32-2V							350 mtph (390 stph)	500 mm (19")
C100™		B10-52-2V				X		X	500 mtph (560 stph)	700 mm (27")
C106™	TK11-42-2V			DET10-38	VG540-3V		X		500 mtph (560 stph)	700 mm (27")
C116™	TK11-42-2V	B10-52-2V				X			500 mtph (560 stph)	700 mm (27")
C120™	TK12-42-2V			DET10-38	VG540-3V		X	X	500 mtph (560 stph)	700 mm (27")
C120™		VF561-2V				X			600 mtph (670 stph)	800 mm (32")
C120™			PF561					X		
C120™				HRBM60-12	VG540-3V		X			
C130™		VF561-2V				X			700 mtph (780 stph)	900 mm (36")
C130™			PF561					X		
C130™				HRBM60-12	VG540-3V		X		600 mtph (670 stph)	
C150™	VF661-2V	VF661-2V				X			1 000 mtph (1 110 stph)	900 mm (36")
C150™			PF661					X		
C150™				HRBM60-15	VG645-3V		X		900 mtph (1 000 stph)	
C160™	VF866-2V	VF866-2V				X			1 300 mtph (1 440 stph)	1 200 mm (47")
C160™			PF661					X	1 000 mtph (1 110 stph)	
C160™				HRBM65-17	VG745-3V		X		1 100 mtph (1 220 stph)	1 000 mm (40")
C160™				HRBM70-19	VG860-4V		X		1 300 mtph (1 440 stph)	1 200 mm (47")
C160™				Apron	LH18-48		X		1 300 mtph (1 440 stph)	1 200 mm (47")
C200™		VF866-2V				X			1 500 mtph (1 660 stph)	
C200™				HRBM70-19	VG860-4V		X	X	1 300 mtph (1 440 stph)	1 200 mm (47")
C200™				Apron	LH21-48		X	X	1 800 mtph (2 000 stph)	

Impact crusher	Grizzly feeder		Separate feeder + grizzly scalper			Recommended for			Capacity *)	Top feed size *)
	Mobile	Stationary	Pan feeder	Push feeder	Grizzly scalper	Regular	Sticky feed	A lot of fines in the feed		
			Stationary							
NP1110M™	TK9-42-2V								400 mtph (440 stph)	600 mm (24")
NP1213M™	TK11-42-2V								540 mtph (600 stph)	600 mm (24")
NP1313™		VF561-2V				X			900 mm (36")	900 mm (36")
NP1313™			PF561		VG540-3V		X	X	620 mtph (690 stph)	900 mm (36")
NP1313™				HRBM60-12			X			900 mm (36")
NP1415™		VF661-2V				X			1 000 mm (40")	1 000 mm (40")
NP1415™			PF661					X	750 mtph (830 stph)	1 000 mm (40")
NP1415™				HRBM60-15	VG645-3V		X			1 000 mm (40")
NP1620™		VF866-2V				X			1 300 mm (51")	1 300 mm (51")
NP1620™				HRBM65-17	VG745-3V		X	X	1000 mtph (1110 stph)	1 100 mm (43")
NP1620™				HRBM70-19	VG860-4V		X	X		1 300 mm (51")
NP1620™				Apron	LH18-48		X	X		1 300 mm (51")
NP2023™		VF866-2V				X			1 800 mtph (2 000 stph)	1 500 mm (59")
NP2023™				HRBM70-19	VG860-4V		X	X	1 300 mtph (1 440 stph)	1 500 mm (59")
NP2023™				Apron	LH24-61		X	X	2 000 mtph (2 220 stph)	1 500 mm (59")

*) Note: Maximum feed rate values are given for material bulk density of 1.6 t/m³ in dry conditions and are indicatives only.



Metso
Application expertise

Bruno™ process simulation tool

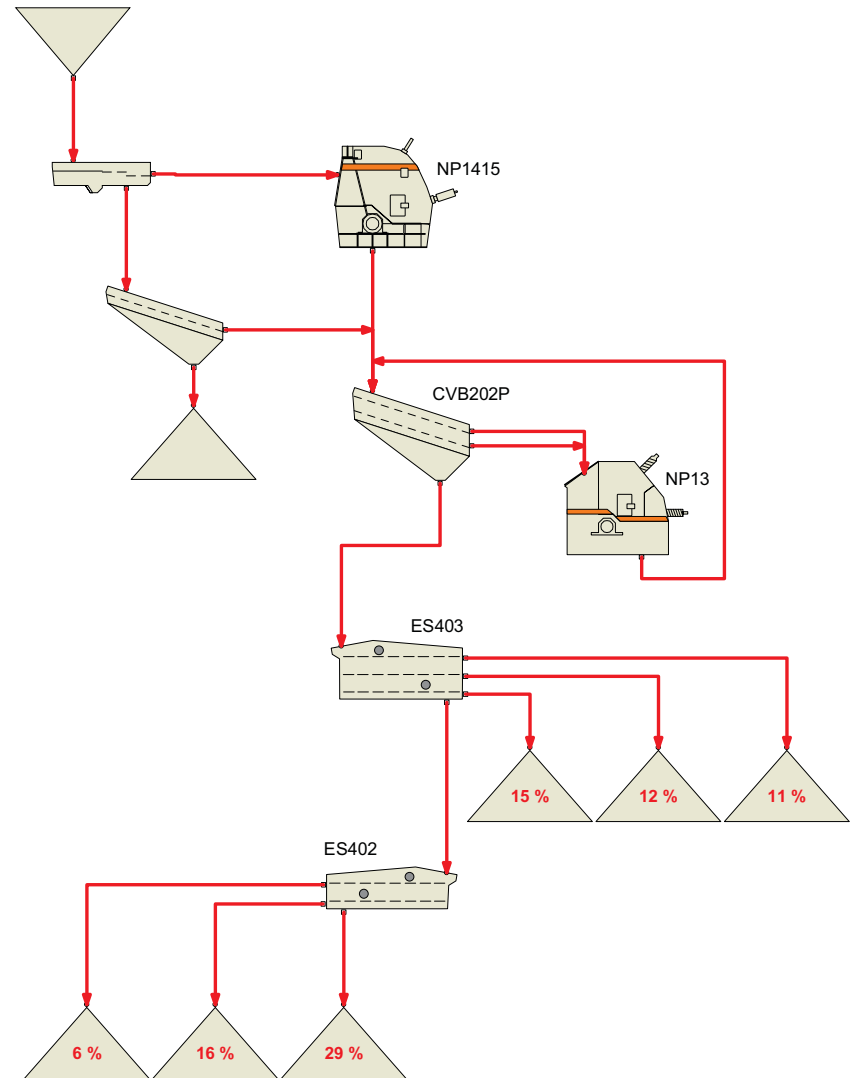
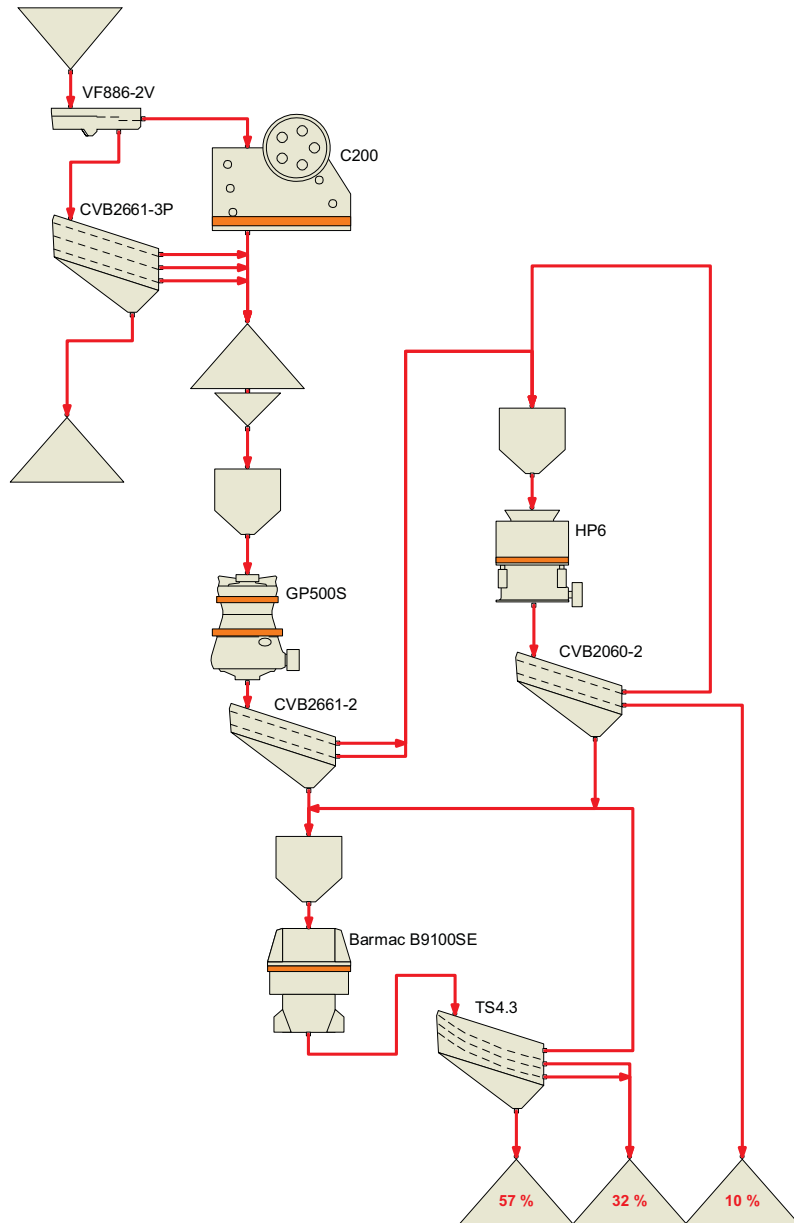

Bruno process simulation tool helps you to maximize crushing plant production

Metso's Bruno process simulation tool helps you to choose the right Metso equipment and helps you to optimize the performance of the crushing plant. The competence and calculation models behind the software are based on thousands of real crushing and screening test results.

Application examples



Application examples





Services

Maximizing your return on investment

Our comprehensive services offering includes everything from original spare and wear parts to customizable service solutions fine-tuned to your specific needs. You can count on Metso's expertise and support, available through our worldwide network of service centers, distribution facilities and regional warehouses. So if it's wear or spare parts support, engineered service solutions, a tailored Equipment Protection Plan or a long term Life Cycle Services contract that you are looking for, we'll make sure that your investments get the attention they deserve.

Spare and wear part support

Our OEM parts help maintain the performance and availability of your equipment, resulting in a lower production cost per ton. Based on a long-term mutual commitment, you can take advantage of benefits such as preferential access to the most critical spare and wear parts.

Metso parts are manufactured according to specific design parameters using high-quality materials, tools and techniques. The use of OEM parts assures optimal performance and equipment availability, resulting in a lower production cost per ton.

Our crusher chamber/liner optimization solution is tailored to your process. This is a continuous improvement program, since the characteristics of the aggregates or the crushing process may vary. Depending on your needs, we can set goals, such as longer wear life, higher capacity throughput, finer material, or shorter downtime on liner changes.

Field Services

We understand our customers' real issues and that success comes from helping you reach your operational and financial goals. Combining our global service network and deep industry knowledge with your operational expertise ensures that we provide the best solutions to deliver quality aggregate and increased productivity, eliminate waste and reduce risk.

We offer a comprehensive set of field services to help meet your maintenance, repair and refurbishment needs, offering a cost-effective alternative to purchasing new or replacement equipment. These services are available at our global service facilities or on site through our experienced field service staff. Backed by years of experience, we can repair broken or damaged equipment to "like-new" condition and restore worn or irreplaceable equipment to perfect operating condition.



Life Cycle Services

Our Life Cycle Services (LCS) take the entire range of services Metso provides to our aggregates customers and conveniently bundle them into customizable, easily manageable packages, ranging from the basics to more complete solutions, depending on the scale of your needs. Metso implements industry best practices at each step of your operation to achieve optimum performance and guaranteed results.

Our Life Cycle Services offering includes equipment support, maintenance services and maintenance and optimization packages.

Equipment Protection Plan

EPP is a reliability assurance program that covers key components of your Metso equipment, representing up to 75% of the complete crushing equipment value. Standard freight and service supervisory work are included in the program coverage.

Scheduled equipment inspection visits from a Metso-certified inspector are part of the program, and ensure that any issues are caught early. Certified inspectors help optimize your equipment's life cycle productivity to enable the lowest sustainable cost of production.



metso

Kari...
01

metso

Endura
HYBRID SUEA
SUPERIOR

The Metso Way – Making the big difference to our customers

Everything we do is based on deep industry knowledge and expertise that makes the big difference to our customers. Decades of close customer collaboration and adapting to our customers' ever changing needs have transformed us into a knowledge company.



Metso Corporation, Lokomonkatu 3, P.O.Box 306, FI-33101 Tampere, Finland, tel. +358 20 484 142, fax +358 20 484 143
www.metso.com

Metso, Lokotrack, Nordberg, Barmac and, Trellex are trademarks or registered trademarks of Metso Corporation or its subsidiaries or affiliates.
*Other names and brands may be claimed as the property of others.
*Caterpillar and CAT are registered trademarks of Caterpillar Inc.